

**Escort Winch, Towline, and
Tether System Analysis
PWSRCAC RFP No. 8570.12.01
Draft Final Report**

Project 212-030

Revision 4

August 24, 2012

Prepared for:

Prince William Sound Regional Citizens' Advisory Council
Anchorage, AK

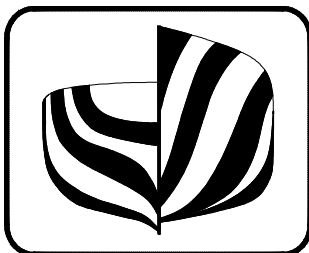

Prepared by:

Robert Allan Ltd.
Naval Architects and Marine Engineers
230 - 1639 West 2nd Avenue
Vancouver, BC V6J 1H3 Canada

Escort Winch, Towline, and Tether System Analysis PWSRCAC RFP No. 8570.12.01 Final Report

Document No.: 212-030

<p><i>Prepared For:</i> Prince William Sound Regional Citizens' Advisory Council Anchorage, AK</p>	<p><i>Client's Reference:</i> PWSRCAC RFP No. 8570.12.01</p>
---	---

<p><i>Author(s):</i> Robert G. Allan, P. Eng.</p>	<p><i>Professional Engineer of Record:</i> Robert G. Allan, P. Eng.</p>
--	--

Revision History

Rev.	Description	By	Checked	P. Eng. of Record	Approved	Issue Date
4	Further minor edits and mods per comments from Client	RGA	RGA	RGA		Aug. 24, 2012
3	Revised and updated per Peer review comments and per comments from PWSRCAC	RGA	RGA	RGA		Aug 7, 2012
2	Revised per late info from Crowley	RGA	RGA	RGA		Jul. 23, 2012
1	First Issue	RGA	RGA	RGA		Jul. 13, 12

Class Approval Status				Client Acceptance Status			
Rev.	Approval Agency	Initials	Date	Rev.	Design Phase	Initials	Date

Confidentiality: Confidential

All information contained in or disclosed by this document is proprietary and the exclusive intellectual property of Robert Allan Ltd. This information is reserved for the exclusive use of Prince William Sound Regional Citizens' Advisory Council of Anchorage, AK. All further use and rights attached thereto are exclusively reserved by Robert Allan Ltd., and any reproduction, communication or distribution of this information is prohibited without the prior written consent of Robert Allan Ltd. Absolutely no modifications or alterations to this document may be made by any persons or party without the prior written consent of Robert Allan Ltd.



DISCLAIMER

*"The opinions expressed in this PWSRCAC-commissioned report are those of the Author
and are not necessarily those of PWSRCAC."*

Contents

INTRODUCTION	1
TERMS OF REFERENCE	1
REFERENCE MATERIALS	3
DEFINITIONS	3
STUDY METHODOLOGY	4
VESSEL INFORMATION	5
PART 1.0 VESSEL EQUIPMENT ASSESSMENT	7
1.1 Towing Gear Inventory	7
1.1.1 ETT Class Tugboats	7
1.1.2 PRT Class Tugboats	8
1.1.3 Other Vessels	9
1.2 Vessel Performance Data	10
1.2.1 Bollard Pull	10
1.2.2 Indirect Steering and Braking Forces	11
1.2.3 Speed	11
1.2.4 Stability Data	12
1.3 Towing Connection Operating Procedures	13
1.4 Towline Maintenance Procedures	13
1.5 Observations	14
1.5.1 Winches	14
1.5.2 Towlines	14
1.5.3 Towline Connection Procedures	14
1.5.4 Towline Maintenance Procedures	14
1.6 Towline or Vessel Incidents	15
1.7 Towing Systems Summary	15
1.8 Conclusions – Part One	16
PART 2.0 TECHNOLOGY SURVEY	17
2.1 Background	17
2.2 Companies Contacted	17
2.3 Tug Fleet Information	18
2.4 Escort Operations – General	20
2.5 Winch Technologies	21
2.5.1 General	21

2.5.2	Electric Winches	21
2.5.3	Hydraulic Winches	22
2.5.4	Load Monitoring	22
2.5.5	Line Management Devices	23
2.6	Escort Towline Technologies	23
2.6.1	General	23
2.7	Towline Composition	27
2.7.1	Main Towlines	27
2.7.2	Towline Characteristics	28
2.7.2.1	Strength	28
2.7.2.2	Weight	29
2.7.2.3	Elongation	29
2.7.2.4	Abrasion Resistance	29
2.7.2.5	Fatigue	30
2.7.2.6	Heat Resistance	30
2.7.2.7	Ultra-Violet Resistance	31
2.7.2.8	Chemical Reactions	31
2.7.3	Line Inspection and Maintenance	31
2.7.4	Stretchers	33
2.7.5	Connections	33
2.7.6	Chafing Protection	35
2.7.7	Towline Strength vs. Power (BP vs. Rope Strength (BS))	36
2.8	Towing Fittings	37
2.8.1	Ship Fittings	37
2.8.2	Tug Fittings - Static	38
2.8.3	Towing Fittings – Active	42
2.9	Comments—Best Available Technology	44
2.10	Summary	44
PART 3.0 BEST AVAILABLE TECHNOLOGY		45
3.1	Winch Specifications vs. Class Rules	45
3.2	Recent Industry Research	49
3.2.1	SAFETUG	49
3.2.2	Winch Manufacturers	49
3.2.3	Rope Manufacturers	50
3.3	Best Available Technology – Current Status	50
3.3.1	Industry Status	50
3.3.2	ADEC Assessment Criteria	52
3.4	Gap Analysis: Present Towing Systems vs. BAT	54
3.4.1	ETT Escort Tugs	55
3.4.2	PRT Escort Tugs	55
3.5	Summary	56
PART 4.0 SUMMARY		56
4.1	Potential Equipment Upgrades	56

4.1.1	Replacement Winch for ETT Class Tugs	57
4.1.2	Replacement Winch for PRT Class Tugs	57
4.2	Vessel Compatibility with Upgrades	58
4.3	Conclusions	59

PART 5.0 RECOMMENDATIONS **60**

ANNEX A	Reference Documents from PWSRCAC
ANNEX B	Towing Gear MV <i>Tan'erliq</i> : ETT Class Tug
ANNEX C	Towing Gear MV <i>Aware</i> : PRT Class Tug
ANNEX D	Photographic Review of SERVS Escort Tugs: Deck Machinery and Towing Systems
ANNEX E	References
ANNEX F	Escort Towing, Winch, and Rope Company Questionnaires
ANNEX G	Comparison of Fiber Characteristics

* * *

Escort Winch, Towline, and Tether System Analysis PWSRCAC RFP No. 8570.12.01 Final Report

**For: Prince William Sound Regional Citizens' Advisory Council
Anchorage, AK**

INTRODUCTION

Robert Allan Ltd. was retained by the Prince William Sound Regional Citizens' Advisory Council (PWSRCAC) under Contract Number 8570.12.01 to conduct an investigation into the nature of the towing systems in use aboard the existing escort tugboats in use within the Ship Escort Response Vessel System (SERVS) in Valdez, Alaska, and to determine how those systems compare to what can be considered as the current Best Available Technology (BAT) in escort towing systems worldwide.

This report constitutes the findings of our research and investigations into this subject.

TERMS OF REFERENCE

The terms of reference for this work were explicitly stated in the Contract as follows:

"Consultant shall perform all the work required by the agreement and any exhibits or change orders thereto for the project. Work [the] Consultant is required to perform for this project consists of the following:

Using the project methodology as presented in the Consultant's proposal as a framework, prepare a detailed work plan and schedule utilizing these deliverable milestones:

- 1. **Towing Gear Inventory.** Compile an accurate inventory of the components used in the towing system on each tug listed in the Vessel Escort and Response Plan (VERP).*
- 2. **Data Collection.** Collect data that defines the actual escort steering and braking force generating capability of each tug type, and the parallel information relative to the stability of all these tugs in the escort towing mode. Relate the force generating capabilities and the stability limitations of the tugs to the capabilities of the winch and towline in each case.*

3. **Review of Previous Studies.** *Review all previous studies and reports relevant to the VERP.*
4. **Operating Procedures.** *Understand and document the operating procedures used for towing gear on each tug type.*
5. **Condition and Reliability.** *Understand and document the maintenance and monitoring procedures in place that ensure the condition and reliability of the towing gear.*
6. **Operator Survey.** *Contact all known operators of comparable escort towing tugs, and compile the same information on the towing systems in use.*
7. **Supplier Survey.** *Contact major winch suppliers and rope manufacturers to gain insight into the very latest developments for current projects.*
8. **Towing Systems State of the Art.** *Compare the present towing systems to the current best practices using the eight (8) stipulated criteria used by the Alaska Department of Environmental Conservation (ADEC).*
9. **Gap Analysis.** *Identify any Gaps or deficiencies in the present system that could be filled or improved by use of more modern towing gear. Identify approximate costs of the upgrades.*
10. **Draft Final Report.** *Provide a summary report defining all findings of the study, and advising what would constitute the best available technology for the Prince William Sound tug fleet, and specifically for tugs operating in the primary and secondary escort roles.*

REFERENCE MATERIALS

Robert Allan Ltd. was provided with an extensive list of reference documents by PWSRCAC, which are listed in Annex A.

In addition, the following materials were provided during the on-board inspection of the major escort tugboats on April 26, 2012:

a. MV *Tan'erliq*: ETT Class Tug:

- Extracts from Data/Instruction Book: Markey Type DYSDS-62 Hawser Winch
- Extracts from Data/Instruction Book: Markey Type WYWD-20 Anchor Windlass/Bow Winch
- List of Lines, Wires and Pennants aboard the vessel
- Certificate of Compliance: Samson Ropes; 14" Circ. Super Strong 200' Grommet
- Certificate of Compliance: Samson Ropes; 10" Circ. Amsteel Blue 200' Pennant

The above information re the ETT Class tugs is attached in its entirety as Annex B.

b. MV *Aware*: PRT Class Tug:

- Extracts from Data/Instruction Book: Markey Type DYS-52/WYW-20 Combination Hawser Winch and Anchor Windlass
- Extracts from Data/Instruction Book: Markey Type TDS-40 Towing Winch
- ASD Tug *Aware*: Emergency Towing Package Specification

The above information re the PRT Class tugs is attached in its entirety as Annex C.

The winch model numbers indicated on these documents were verified against the nameplate data on the winches installed on the vessels. The towlines were sighted in place, and the data provided with regard to towline component fittings and lengths was assumed as accurate. It was further assumed that the gear listed is identical within each vessel type.

DEFINITIONS

- Ton = a "short" ton = 2,000 lbs.
- Long Ton (L.Ton) = 2,240 lbs.
- Tonne = a "metric" ton = 1,000 kilograms = 2,205 lbs.
- Bollard Pull—the maximum force which a tug can generate at full power and at zero speed ahead. Note that this term is NOT valid as a description of the forces generated during moving escort or towing operations
- Indirect Steering Force (F_s)—the force in the horizontal plane generated by a tugboat at right angles to the direction of travel of the tanker (or any attended ship) during an indirect towing manoeuvre

- Indirect Braking Force (F_b)—the force in the horizontal plane generated by a tugboat parallel and opposite to the direction of travel of the tanker (or any attended ship) during an indirect towing manoeuvre
- Towing Force—the resultant force in the horizontal plane obtained by the combination of the indirect steering and indirect braking forces along the line of the towline
- Towline Force—the maximum resultant force in the line of and in the plane of the towline obtained by the combination of the indirect steering and indirect braking forces along the line of the towline (Note: That this tension includes the vertical components.)
- Transverse Arrest—a manoeuvre executed by an escort tug where the thrust from each of two drives is directed at close to right angles to the tug centreline, thereby creating an additional drag force
- Direct Arrest—a force created by a tug where the thrust is directed towards the escorted vessel with the towline aligned with the centreline of the tug
- Tractor Tug—a tugboat with the propulsion units (drive units) located in the lower forebody of the vessel, at approximately $1/3$ of the length from the bow
- Azimuthing Stern Drive (ASD) Tug—a tugboat with steerable right angle drive propulsion units (also referred to as Z-drives), located in the aft part of the tug hull
- Voith-Schneider Propeller (VSP)—a patented device (generically known as a "Cycloidal Propeller") which generates thrust through a series of vertical foil-shaped blades that rotate on a plate mounted in the bottom of a vessel, changing their angle of attack during the cycle of rotation and thus generating thrust in the selected direction. VSP drive units are commonly mounted in a side-by-side pair in a "Tractor Tug" arrangement, although other configurations can be used

STUDY METHODOLOGY

The methodology employed for this study was fairly straightforward, as defined in the submitted Work Plan, as follows:

- a. Visit the vessels and ideally attend an escort operation on each vessel type.
- b. Verify data concerning existing winches and tows.
- c. Collect information on system maintenance and inspection processes.
- d. Collect information on tug-ship connection methodologies.
- e. Collect information on any rope wear problem areas or winch operation shortcomings.
- f. Review all available information.
- g. Contact other vessel operators re best escort practices and equipment.
- h. Contact winch and rope manufacturers re current technologies and practices.
- i. Compare the best technology available (as defined by others) against the ADEC evaluation criteria.
- j. Identify gaps or deficiencies in the present system that could benefit from improved technologies.
- k. Summarize all the above in a final report.

A visit to the tugboats was scheduled and took place in Valdez, Alaska on April 26, 2012, and was conducted by Robert G. Allan, P. Eng. of Robert Allan Ltd., in company with Mr. Alan Sorum of PWSRCAC. Due to schedule constraints and the lack of tankers calling at Valdez during the visit period it was not possible to witness any actual tanker escort operations. Photographs taken of the vessels and the towing gear during the subject visit are attached as Annex D.

VESSEL INFORMATION

The total SERVS system includes the following tugs:

- *Endurance* - twin-screw conventional tug
- *Sea Voyager* - twin-screw conventional tug
- *Stalwart* - twin-screw conventional tug
- *Guardian* - twin-screw conventional tug
- *Invader Class* - twin-screw conventional tug
- *Bulwark* - twin-screw conventional tug

ETT Class - VSP Tugs:

- *Nanuq*
- *Tanerliq*

PRT Class - ASD Tugs:

- *Alert*
- *Aware*
- *Attentive*

Note: It was agreed with PWSRCAC at the outset that this study should be restricted only to the ETT and PRT Class tugs, as these are the primary escort tugs in the system.

The following are the salient characteristics of the major escort vessels within the SERVS system, as established from the various referenced documents:

a. ETT Class Tugboats

- Vessel type - VSP Tractor Tug
- Class notation - ☒ A1 Towing Service, ☒ AMS, ☒ A1, Fire-Fighting Vessel Class 1 (FFV1)
- Length, overall - 153'-0"
- Beam, molded - 48'-0"
- Depth, molded - 20'-0"
- Load draft - 21'-4"
- Propulsion type - VSP
- Propulsion make/model:
 - engines - CAT 3612B rated 5,096 bhp at 900 rpm
 - drives - VSP Model 36 GII/260
- Power - 10,192 bhp

b. PRT Class Tugboats

- Vessel type - ASD Tug
- Class notation - ☒ A1, Fire-Fighting Vessel Class 1, US Domestic Service, ☒ AMS
- Length, overall - 140'-0"
- Beam, molded - 42'-0"
- Depth, molded - 20'-0"
- Load draft - 17'-0"
- Propulsion type - Z-drive (ASD)
- Propulsion make/model:
 - engines - CAT 3612B rated 5,096 bhp at 900 rpm
 - drives - Aquamaster US 5001 CP
- Power - 10,192 bhp

PART 1.0 VESSEL EQUIPMENT ASSESSMENT

1.1 Towing Gear Inventory

Based on the information gathered during the vessel site visit, the towing gear listed below is that presently aboard the primary classes of escort tugs. It is assumed that all vessels of each class are identical in this respect.

1.1.1 ETT Class Tugboats

a. Hawser Winch (Aft):

- Markey Type DYSDS-62 Double (Split) Drum Hawser Winch
 - hydraulic driven
 - capacity of each drum: 1,000' of 12" circumference synthetic line
 - mechanical (hydraulic) brake capacity: 600,000 lbs. at full drum
 - performance:
 - slow speed range: 25,000 lbs. line pull at 125 fpm
 - high speed range: 12,000 lbs. line pull at 250 fpm
 - limited rendering capability: for slack line operations only
 - wheelhouse remote controls
 - line length out and line tension displays at aft console
 - no spooling (level wind) device

b. Windlass/Bow Winch:

This windlass/winch forward is small and is reported to be used only for miscellaneous barge handling operations, and would never be used in any escort operations. Its characteristics are therefore not reported here and are considered irrelevant to the escort capability of the tugboats.

c. Hawser on Aft Winch:

The working hawser on this tug is located on the starboard drum of the hawser winch. The port drum contains the emergency towing gear. The escort hawser makeup, from drum core outward, is as follows:

- Backing Line *: 10" circumference x 200' Stable Braid-uncoated Polyester
- Samson "Neutron 8": 1,000' x 11" circ.
- Samson "Saturn" Pennant: 100' x 10" circ.

The outer 50–60 feet of the pennant has abrasion protection sheathing. There is some abrasion protection in the form of a canvas or similar woven material jacket on the extreme outer end of the hawser eye itself, but not on the full length of the eye.

1.1.2 PRT Class Tugboats

a. Towing Winch:

- Markey TDS-40 single drum towing winch:
 - direct geared diesel drive (engine mounted on winch frame)
 - drum capacity - 2,500' of 2-1/2" steel wire rope
 - mechanical (pneumatic) brake capacity - 275,000 lbs. at full drum
 - normal speed range:
 - 315,000 lbs. at 5 fpm (bare drum)
 - 140,000 lbs. at 11 fpm (full drum)
 - high speed range - 1/2 of line pulls noted above at 2x line speeds
 - wheelhouse remote controls
 - line length out and line tension displays at aft console
 - no spooling (level wind) device

b. Hawser Winch/Windlass (Forward):

- Markey Type DYS-52/WYW-20 combination single drum hawser winch/windlass:
 - hydraulic driven
 - drum capacity: 700' of 10" circumference synthetic line see (e.) below
 - mechanical (hydraulic) brake capacity - 320,000 lbs. at full drum/480,000 lbs. at mid-drum
 - performance: 16,500 lbs. line pull at up to 230 fpm at mid-drum
 - render/recover capability (limited)
 - wheelhouse remote controls
 - line length out and line tension displays at aft console

c. Main Towline:

- 6 x 36 IWRC steel wire rope: 2,500' x 2-1/2" diameter

d. Emergency Towing Gear:

The emergency towing gear is flaked out in a "tray" atop the towing winch ready for deployment (Annex D, Figure D.2) and is shackled into the main steel tow wire. The surge chain is stowed on the main deck, lashed to the bulwark stays.

From the steel towline outward the components are as follows:

- Nylon "Grommet" – 250' x 15" circ. RP12 Nylon
- Amsteel blue synthetic line: 250' x 10" circ.
- Connecting shackles (2): 3" diameter, 85 ton SWL (Note: This 85 ton load rating is insufficient for the tug power and a verbal enquiry was made to Crowley on about August 15 to clarify. They advise the SWL of the shackle is about five (5) times

- higher, but at time of report completion no specific alternate SWL is available.)
- Surge chain: 3" diameter stud link chain, 45' length
- Messenger line: 2 x 300' x 5-1/2" circumference plaited polyethylene

e. Hawser on Bow Winch:

- Backing Line *: 9" circumference x 150' RP-12 polyester
- 800' of 10" circ. Amsteel Blue, plus
- 100' of 10" circ. Amsteel Blue as a Pennant, connected eye-to-eye to the main hawser line
- Ref. [A1-15] (Leonard) defines the manner in which this line is to be stowed on the towing drum

Note: At one time a "blanket" of Spectra fibre was installed at an intermediate level of the line wraps in order to prevent the line biting deeply into the rope layers. At the time of the visit to the tugs the information provided indicates that this device was no longer in use, however some confusion persists as to whether or not the blanket is in fact still in use. This must be clarified, **however the use of a layer of material like Spectra seems a reasonable device to prevent line damage, and has been endorsed by the rope manufacturer.**

* Note that the presence of the "Backing Lines" was only clarified late in August 2012. The material is used to provide a tightly wound, slip-resistant core of rope against which the HPME line would bear, and which prevents the HPME line itself from slipping on the drum, which is a common problem due the low coefficient of friction of the HMPE lines. As this line is located only at the core of the drum in one or at most two layers, and as the tension in the towline does not transmit through the entire length of the towline but is dissipated in friction primarily in the first few wraps, the presence of this lower strength line in the system presents no problem whatsoever to the security of the towline system.

1.1.3 Other Vessels

For sake of completeness the following tables of towing gear on the various twin-screw conventional tugs is provided, however it must be noted that these towing systems are NOT used in any indirect escort towing manoeuvres.

Table 1.1 Twin-Screw Escort Vessel Primary Tow and Rescue Tow Gear

Vessel	Primary Wire		Shock Line/Surge Gear			HMPE Pendant		
	Dia.	Length*	Type	Size/Dia.	Length	Circ.	Length	Eye
<i>Sea Voyager</i>	2.75"	4,000'	Chain	3"	45'	9"	450'	9'
"	2.25"	2,200'	Chain	3"	90'	8"	350'^	7'
<i>Endurance</i>	2.25"	2,700'	Chain	3"	90'	8"	350'^	7'
<i>Stalwart</i>	2.25"	2,700'	Chain	3"	90'	n/a	n/a	n/a
<i>Guardian</i>	2.25"	2,200'	Chain	3"	90'	8"	350'^	7'
<i>Invader Class</i>	2.25"	2,200'	Chain	3"	90'	8"	350'^	7'
<i>Bulwark</i>	2.25"	2,700'	Chain	3"	90'	8"	350'^	7'

Table 1.2 Twin-Screw Escort Vessels: Emergency Towing Packages

Vessel	Emergency Tow Package			
	Chain	HMPE Pendant	Ultra Blue Messenger 2 EA.	Rescue Hook
<i>Endurance</i>	3" x 45'	9" x 450'	1.25" x 300'	3.5"
<i>Sea Voyager</i>	3" x 45'	9" x 450'	1.25" x 300'	3.5"
<i>Stalwart</i>	3" x 45'	7.5" x 450'	1.25" x 300'	3.5"
<i>Guardian</i>	3" x 45'	7.5" x 450'	1.25" x 300'	3.5"
<i>Invader Class</i>	3" x 45'	7.5" x 450'	1.25" x 300'	3.5"
<i>Bulwark</i>	3" x 45'	7.5" x 450'	1.25" x 300'	3.5"

Table 1.3 Twin-Screw Escort Vessel Primary Escorting/Ship Assist Gear

Vessel	Messenger			Bow/Tether Lines			
	Type	Circ.	Length	Type	Circ.	Length*	Eye
<i>Endurance</i>	Dura-Plex	1" 1"	100' 120"	Proton-8	5"	200'	7'
<i>Stalwart</i>	Dura-Plex	1" 1"	100' 120"	Quantum-12	8"	200'	7'
<i>Sea Voyager</i>	Dura-Plex	1" 1"	100' 120"	Sampson RP-12	8"	200'	7'
<i>Invader Class</i>	Dura-Plex	1" 1"	100' 120"	Quantum-12	8"	200'	7'
<i>Guardian</i>	Dura-Plex	1" 1"	100' 120"	Quantum-12	8"	200'	7'
<i>Bulwark</i>	Dura-Plex	1" 1"	100' 120"	Quantum-12	8"	200'	7'

1.2 Vessel Performance Data

1.2.1 Bollard Pull

The following information was extracted from the data records provided. Alpha-numeric in parentheses [] refer to the various Annexes:

a. ETT Class Tugs:

1. BP ahead = 95.2 tonnes (210,500 lbs.) [A1-1]
2. BP astern = not recorded

At 20.6 lbs./bhp this data is fairly typical of the specific thrust generated in VSP-propelled tugboats of this vintage. In more recent years Voith have improved the efficiency of their blade designs and are thus now generating slightly more thrust for the same power:

- Indirect Steering Force Capability at 8 knots - *nothing documented*
- Indirect Steering Force Capability at 10 knots - *nothing documented*
- Indirect Braking Force Capability at 8 knots - *nothing documented*
- Indirect Braking Force Capability at 10 knots - *nothing documented*

b. PRT Class Tugs:

1. BP ahead = 305,000 lbs. (138.3 tonnes) [A1-2]
2. BP astern = 270,000 lbs. (122.4 tonnes) [A1-2]

At 29.9 lbs./bhp the specific thrust (bollard pull) ahead is consistent with or even slightly better than most ASD tugboats. The BP astern, at 88.5% of the ahead value, is however considerably lower than the values currently being achieved by other high performance ASD escort tugs of similar size and power, where ratios of BP astern/BP ahead are closer to 95%. (e.g. *Svitzer Kilroom*: 8,196 bhp, 113 tonnes BP ahead; 107 tonnes BP astern. Specific Thrust = 30.4 lbs./bhp; BP astern/BP ahead ratio = 0.95)

- Indirect Steering Force Capability at 8 knots - *nothing documented*
- Indirect Steering Force Capability at 10 knots - *nothing documented*
- Indirect Braking Force Capability at 8 knots - *nothing documented*
- Indirect Braking Force Capability at 10 knots - *nothing documented*

1.2.2 Indirect Steering and Braking Forces

At the time of drafting this report, no data was available which defined or calculated the indirect towing performance of either vessel type. The DNV review of the SERVS tugs [A2-1] also noted that no recorded indirect performance testing data was available for either tug class. This information, if available, was requested of SERVS during the site visit on April 26 but nothing has been forthcoming.

1.2.3 Speed

The recorded trial speeds of the escort tugs are as follows:

- ETT Class - 14.5 knots [A1-3]
- PRT Class - 16 knots [A1-4]

1.2.4 Stability Data

The most current stability data for each vessel type is documented as follows:

- ETT Class:
 - MV *Nanuq*:
 - USCG Stability Letter [A1-5]
 - Guido Perla Associates (GPA) Scientific Trim and Stability Calculations (ABS Approved) [A1-14]
 - MV *Tan'erliq*:
 - USCG Stability Letter [A1-6]
 - GPA: Scientific Trim and Stability Calculations (Preliminary) [A1-7]
- PRT Class:
 - MV *Alert*:
 - Inclining Test Results [A1-8]
 - USCG Stability Letter, July 19, 2000 [A1-9]
 - GPA Stability Calculations [A1-10], [A1-11], and [A1-12]
 - MV *Aware*:
 - ref. [A1-9] cites the *Aware* as the inclined vessel; assumed *Alert* is identical
 - MV *Attentive*:
 - (no specific data available—assumed identical to *Alert* and *Aware*)

In this instance there is a minor discrepancy between the actual as-inclined Lightship value measured and as reflected in the Stability Letter, and the calculated weight used in the detailed stability calculations. In this instance the as-inclined Lightship value for the *Aware* was 849.36 L.Tons [A1-9] and the estimated value was 836.84 L.Tons [A1-10]. This difference is very small and does not materially affect the outcome of any stability assessment, however it is assumed that there exists a comprehensive stability assessment based on actual as-inclined weights and CG values, as it was for the ETT tugs. If this data exists it should be provided, but with such a small difference it would not materially affect the conclusions of this report.

It is noted that the Classification Society Tug Review [A2-1] performed by DNV in 2011 relied upon the calculated values of lightship and CG position as defined in [A1-7] for the ETT Class tugs, rather than the true as-inclined values per [A1-14]. This is a very significant discrepancy of more than 10% of the vessel's lightship weight (estimated at 935 L.Tons vs. as-inclined of 1047.3 L.Tons for *Nanuq*). The result of this oversight is that the assessment of the escort rating potential for the tugs is actually considerably worse than advised by DNV in the case of the ETT tugs and only marginally worse in the case of the PRT tugs.

The initial stability (GM) values indicated in the Stability letters are reasonable for these types of tugs, however the relatively low freeboard of the PRT class in particular restricts the range of positive righting lever (GZ), thus offering limited range of positive stability should the tug be heeled over during an escort operation. Although we were advised that the PRT tugs do not operate in the indirect mode, the potential for a transverse pull on the towline does exist and so this characteristic could be considered as a deficiency. The DNV study [A2-1] also drew attention to the fact that the PRT Class failed to meet international towing stability criteria in all but the full load conditions, and suggested that the vessel be ballasted to increase GM or that total deadweight be reduced. It is not clear that any of those recommendations have been implemented. With the significant discrepancy between the preliminary data used by DNV and the actual final stability data more recently made available, the DNV findings will in fact be much worse than indicated.

1.3 Towing Connection Operating Procedures

Open discussions with the Masters of both the MV *Tan'erliq* and the MV *Aware* provided the following description for standard procedures for connection to a tanker to be escorted:

- Tug approaches from astern and noses close to the ship's transom
- A reasonable length of towline is flaked out on deck ready to deploy
- The tanker crew lower a heaving line which is connected to the towing hawser
- The ship's crew haul the hawser to the mooring deck and connect the eye of the hawser to the center aft towing bitt
- The tug backs away until all slack line is paid out, then the winch is activated to release more line as needed
- In the PRT class the winch brake is set to render mode at the desired tension
- In the ETT class the winch brake is set with no automatic render-recover capability

1.4 Towline Maintenance Procedures

Both vessel Masters described the following towline maintenance procedures:

- Pennants are changed out every 6 months
- The main hawser is rotated end for end every year, and is replaced after two years
- The full length of line is physically inspected every month
- The line is visually checked for abrasion or other damage on every deployment.

In addition the standing orders for stowing the lines on the drums "PRT Tether Line Stowage" [A3-1] follow what seems to be widespread good practice to ensure that the line is tightly spooled onto the drum in order to prevent the outer layers biting down into lower layers of rope. Two such incidents which occurred in 2004 are discussed in the referenced materials; [A3-2], and [A3-3].

1.5 Observations

1.5.1 Winches

The winches on both tugs were well-maintained and appeared to be in good working order, although in neither case were the winches operated during the inspection.

The absence of a working load render-recover capability on the ETT class tugs is considered a deficiency in a modern escort capable tug, especially one operating in higher sea-states. Dynamic loads on a hawser can exceed 10 x the rated Bollard Pull of a tug in extreme sea-states, and that will far exceed the rated breaking strength of the towline. Without a render-recover capability the system is entirely reliant on the skill of the Master to try to avoid incurring high snatch loads on the towline, but even the most talented skipper cannot preclude all such events. Trying to manage towline loads by manoeuvring a 1000 tonne vessel is not practical and ultimately leads to less efficient force application to the attended ship. In addition, the absence of a spooling gear (or "level-wind") device on both winches can be viewed as a deficiency which could contribute to line wear and/or line failure. Refer to section 2.5.5 on escort winch technology.

1.5.2 Towlines

The towlines on both vessels were covered by tarpaulins to protect the lines from the effects of the elements (snow, rain, and sunlight), which is certainly good practice. The lines were thus not fully sighted, but the portions visible all appeared to be in very good condition and the working ends were well protected by the use of anti-chafing gear.

1.5.3 Towline Connection Procedures

These operations are reported to be satisfactory for all operations, and certainly would be in outbound calm conditions. When connecting to a ship in rough seas however this operation is undoubtedly more difficult. More information about how the tugs operate in rough weather would be helpful.

1.5.4 Towline Maintenance Procedures

The towline maintenance procedures described in Section 1.4 follow best industry practice.

1.6 Towline or Vessel Incidents

Among the information reviewed were several reports of towline failures or similar incidents affecting vessel availability. The basic information re these incidents is as follows:

- a. *Aware*: December 21, 2003 – Towline parting in heavy weather. [A1-16]
- b. *Aware*: June 22, 2004 – Towing line parting. [A1-16]
- c. *Attentive*: 2012 – Main engine shutdown due to over-speed trip. [A1-17]

It is not evident from the data provided if any other similar incidents have occurred in the operation of the vessels, but it seems likely that there must be a few more such incidents in the total life of the four subject vessels.

1.7 Towing Systems Summary

The towing systems and equipment in use on the ETT and PRT class tugs within the SERVS system were sighted and documented by the Author of this report. Further data regarding these systems was collected from the operators and from the reference data provided.

Only the ETT class tugs are designed to and operationally execute indirect towing manoeuvres. The actual indirect Steering and Braking Force values which can be developed by this vessel class are not available, if in fact they have ever been recorded, and accordingly it is impossible at this juncture to evaluate the strength rating of the towing gear to the actual forces which can be generated by the tug. Reasonable empirical estimates of the indirect steering and braking capability of the tug can however be made based on data from similar vessels.

The ETT winch lacks a render-recover capability at the rated working load of the winch.

The PRT winch does have a limited render-recover capability but its full range/capacity is not clearly defined in any of the documents provided. If, as is the norm, it covers the full working range of the winch, then one can assume the winch will render only up to 16,500 pounds line force at up to 320 fpm. This must be verified (ref. Annex C).

1.8 Conclusions – Part One

The towing gear in place on the ETT and PRT Class tugboats within the SERVS system are very high quality, and at the time of the building of these vessels were probably considered state of the art. However the absence of a render-recover type winch on the ETT class VSP tractor tugs is considered a fairly significant deficiency in comparison to escort-rated tugboats being built in say the past 5 years, all of which, to the best of the Author's knowledge, have some rendering capability at or near the expected maximum line tension which can be generated by the tug in either a direct or indirect mode of operation. The description of the current state of the art in winch and rope technologies will be documented in the next part of this report.

The absence of an accurate record or even a reasonable prediction or analysis of the indirect towing capability of both tug classes makes it very difficult to accurately consider the strength of the towing systems against this important criterion.

PART 2.0 TECHNOLOGY SURVEY

2.1 Background

The second stage of this study involved a survey of the latest technologies used in escort towing systems in use in various jurisdictions worldwide. In order to complete this work companies known to the authors to be actively involved in escort towing operations or involved in supplying towing system equipment to operators engaged in escort operations were contacted directly.

It must be noted that in fact very few places in the world have such structured escort services as the system that exists in Prince William Sound. Comparable examples would be North Puget Sound, Southampton UK, Milford Haven UK, various Norwegian Oil terminals (Sture, Mongstad, etc.), and some Middle East Gas terminals. However it is fair to say that Valdez/Prince William Sound is certainly one of the longest escort operations in terms of distance, and presents the most demanding environmental challenges of all of these, save the fact that the European terminals are generally much busier.

2.2 Companies Contacted

The following companies were contacted and requested to complete the questionnaires attached as Annex F. In addition, several of the companies in all three groups were contacted and interviewed personally by R.G. Allan during the International Tug & Salvage Conference held in Barcelona, Spain in late May 2012:

a. Towing Companies:

- Boston Towing & Transportation* - USA
- Bukser og Berging AS* - Norway
- Foss Maritime - USA
- G&H Towing Company - USA
- IRSHAD* - UAE
- KOTUG* - Netherlands
- Lamnalco* - UAE
- Moran Towing Corporation - USA
- Østensjø Rederi AS - Norway
- Seaspan Marine Corporation* - Canada
- SMIT BV - Netherlands
- Svitzer AS - Denmark

b. Rope Manufacturers:

- Cortland Ropes* - USA
- Lankhorst Ropes* - Netherlands
- Samson Ropes* - USA

c. Winch Manufacturers:

- Ibercisa - Spain
- JonRie Inter Tech* - USA
- Karmøy AS - Norway
- Kraaijeveld BV - Netherlands
- Markey Manufacturing Ltd.* - USA
- Ridderinkhof BV - Netherlands
- Rolls-Royce* - Norway/Finland

Of the above, quite complete responses were received from 6 towing companies, 4 winch manufacturers, and all 3 rope manufacturers, all of which are identified by an asterisk (*) above. Two other of the towing companies above indicated they would respond, but as of the completion date for this report nothing had been received. In-depth discussions were held with another of the winch companies above during ITS and considerable information was collected, but they did not complete the survey as requested.

In order to protect the confidentiality of this information with regard to sources, the detailed responses by company will NOT be included in this report, but rather a detailed summary of the critical elements is included.

2.3 Tug Fleet Information

Table 2.1 overleaf summarizes the particulars of only those escort-rated tugboats operated by the Owners that responded to the questionnaire. Clearly the majority of these tugs are somewhat, or even considerably, smaller than the SERVS tugs. The group of tugs shown are believed to represent a good cross-section of the tugs providing comparable escort service worldwide. More data was anticipated from one or two large towing companies, but was not received in time to be included in this report.

Table 2.2 following provides data for other major escort tugs designed by Robert Allan Ltd. and which are known to provide comparable service to the SERVS tugs in other areas. These Owners did not respond in time to be included. The data however serves well to expand the tug database to include a number of both VSP and ASD escort tugs of equal or greater capability than the SERVS tugs.

Table 2.1 Escort-Rated Tugboats by Owners that Responded to the Questionnaire

Company	Vessel Name	Vessel Type or Designer/Builder Model (if applicable)	Length Overall (metres)	Power (kW)	Bollard Pull (tonnes)	Type of Propulsion: (VSP, ASD or Z-Tractor)	Specific Thrust (kG/kW)
IRSHAD	<i>Al Qubah</i>	RAstar3600	35.8	4826	83	ASD	17.2
	<i>Al Qafai</i>	RAstar3600	35.8	4826	81.5	ASD	16.9
	<i>Egmais</i>	RAstar3600	35.8	4826	83	ASD	17.2
	<i>Attaf</i>	RAstar3600	35.8	4826	83	ASD	17.2
	<i>Khasifa</i>	Escort Tug, FiFi Ship	32.0	3840	65	ASD	16.9
	<i>Mezyad</i>	Escort Tug, FiFi Ship	32.0	3840	65	ASD	16.9
	<i>Al Buzem 3</i>	RAstar3600	35.8	5220	84	ASD	16.1
	<i>Al Aryam</i>	RAstar3600	35.8	5220	84	ASD	16.1
	<i>Hanyurah</i>	RAstar3600	35.8	5220	84	ASD	16.1
	<i>Ras Em Shaireb</i>	RAstar3600	35.8	5220	84	ASD	16.1
	<i>Al Bateen1</i>	Escort tug, FiFi1	32.0	4050	65	ASD	16.0
Boston Towing	<i>Justice</i>	RAmparts 3000	29.9	4028	65	ASD	16.2
Bugsier of Bergning	<i>Boris</i>	VWT	40.5	n/a	90	VSP	n/a
	<i>Banak</i>		37.0	n/a	75	ASD	n/a
	<i>Barents</i>		37.0	n/a	75	ASD	n/a
	<i>Baut</i>	VWT	40.5	6880	90	VSP	13.1
	<i>Boxer</i>	VWT	38.9	5070	65	VSP	12.8
	<i>Belos</i>	VWT	32.4	3448	50	VSP	14.5
	<i>BB Worker</i>		37.0	4500	90	ASD	20.0
	<i>BB Server</i>		37.0	4200	70	ASD	16.7
Kotug	<i>RT Magic</i>	RotoR-tug	32.0	4698	78	3 x Z-Drive	16.6
	<i>RT Claire/RT Stephanie</i>	RotoR-tug	28.0	3969	65	3 x Z-Drive	16.4
	<i>RT Adriaan</i>	Eco RotoR-tug	32.0	5295	84	3 x Z-Drive	15.9
	<i>RT Tough/RT Force</i>	RotoR-tug	32.0	4962	81	3 x Z-Drive	16.3
Seaspan	<i>Seaspan Resolution</i>	RAL AZ 30-80	30.0	4476	80	ASD	17.9
	<i>Seaspan Eagle</i>	RAstar 2800	28.2	3879	70	ASD	18.0
	<i>Seaspan Raven</i>	RAstar 2800	28.2	3879	70	ASD	18.0
	<i>Seaspan Osprey</i>	RAstar 2800	28.2	4698	80	ASD	17.0
	<i>Seaspan Kestrel</i>	RAstar 2800	28.2	4698	80	ASD	17.0
Smit-Lamnalco	<i>Lamnalco Aden</i>	RAstar3600	35.8	6120	100	ASD	16.3
	<i>Lamnalco Sanaa</i>	RAstar3600	35.8	6120	100	ASD	16.3
	<i>Lamnalco Hodeidah</i>	RAstar3600	35.8	6120	100	ASD	16.3
	<i>Lamnalco Mukalla</i>	RAstar3600	35.8	6120	100	ASD	16.3
	<i>Lamnalco Leopard</i>	Damen 3213	32.1	4800	78	ASD	16.3
	<i>Lamnalco Lion</i>	Damen 3213	32.1	4800	78	ASD	16.3
	<i>Lamnalco Cougar</i>	Damen 3213	32.1	4800	78	ASD	16.3
	<i>Lamnalco Puma</i>	Damen 3213	32.1	4800	78	ASD	16.3
	<i>Lamnalco Eider</i>	RAmparts 3200	32.0	3676	65	ASD	17.7
	<i>Lamnalco Egret</i>	RAmparts 3200	32.0	3676	65	ASD	17.7
	<i>Lamnalco Eagle</i>	RAmparts 3200	32.0	3676	65	ASD	17.7

Table 2.2 Additional Escort Tugs from Robert Allan Ltd. Files

TABLE 3.2 ADDITIONAL ESCORT TUGS FROM RAL FILES							
Company	Vessel Name	Vessel Type or Designer/Builder Model (if applicable)	Length Overall (metres)	Power (kW)	Bollard Pull (tonnes)	Type of Propulsion: (VSP, ASD or Z-Tractor)	Specific Thrust (kG/kW)
Ostensjo Rederi AS	Ajax	RAL - AVT 3900	39.1	7600	95	VSP	12.5
	Velox	RAL - AVT 3600	37.0	4880	65	VSP	13.3
	Apex	RAL - AVT 3600	37.0	4880	65	VSP	13.3
	Phenix	RAL - AVT 3600	37.0	4880	65	VSP	13.3
	Tenax	RAL - AVT 3600	37.0	4880	65	VSP	13.3
Svitzer AS	Svitzer Kilroom	RAstar 3900	39.1	6104	117	ASD	19.2
	Svitzer Lindsway	RAstar 3400	34.0	5800	100	ASD	17.2
	Svitzer Haven	RAstar 3400	34.0	5800	100	ASD	17.2
	Svitzer Waterston	RAstar 3400	34.0	5800	100	ASD	17.2
	Svitzer Caldey	RAstar 3400	34.0	4400	82	ASD	18.6
	Svitzer Ramsey	RAstar 3400	34.0	4400	82	ASD	18.6
	Svitzer Pembroke	RAstar 3600	35.8	6104	105	ASD	17.2
Boston Towing	Independence	RAstar 3900	39.1	4000	70	ASD	17.5
Bourbon	Bourbon Yack	RAstar 3800	38	5940	105	ASD	17.7

The data collected above (Table 2.1) is believed to be correct but has not been completely verified; as the data is as provided by the Owners. The comparison of specific thrust of the drive installations is interesting from a number of perspectives: a) it clearly shows the relative efficiency of screw propellers compared to cycloidal (Voith) propellers, b) it shows the relative efficiency of various installations which can be attributable to many factors; hull design, trial conditions, propeller design, fouling etc., and finally, c) it shows up anomalies which are most likely to indicate an error in the data rather than a very exceptional (or even extraordinarily bad!) performance.

2.4 Escort Operations – General

Before delving into the specific mechanics of the winches and ropes, it is perhaps worthwhile to comment on the fundamental objectives of an escort system and the role played by the various constituent components. In the past decade or so much work has been done in this field and it is important to define the objectives of a workable escort system. Many of the responses received stressed these elemental issues as well:

- a. The basic objective of an escort towing system is to provide a capable and appropriately designed and equipped tugboat which can rapidly apply an external force to an attended ship in the event of a failure of the steering or propulsion system of the ship, to prevent a grounding or collision.
- b. The system must be designed to ensure reliable performance in the full range of environmental operating conditions during which escorts take place.

- c. The objective should be to stay connected in any conceivable situation in the escort profile.
- d. There should be redundancy in the system such that a failed towline (for example) can be rapidly (immediately?) replaced without prejudicing the escort operation.
- e. All components within the system must have strength proportional to the worst expected loads, and in appropriate relationship to each other.
- f. The towline should NOT be the weak link in an escort system; losing control of the tow is highly undesirable in any escort operation.
- g. The winch brake must be the "fuse" in the escort system that prevents the line tension exceeding the breaking strength of the towline (or of any other component of the system).
- h. Training of the tug's crew, the ship's crew and the Pilots in all aspects of escort towing is perhaps the most essential aspect of a successful escort towing operation, such that the "unforeseen event" has been rehearsed and the responses are second nature to the crews at both ends of the towline.
- i. Maintenance of all components of the towing system in peak working order and condition is essential.

2.5 Winch Technologies

2.5.1 General

Without doubt escort winch characteristics have changed more than anything else in escort technology in the past 10–15 years. Due to the demands of various projects and ongoing research into the problems encountered, winches have been built recently which could never have been conceived of at the time of building the SERVS tugs. The evolution of various forms of what are essentially constant tension winches for this application has led to some very significant developments, and a small handful of winch manufacturers worldwide have established themselves as world leaders in this field. Most critically, winch braking systems have evolved to the point where they are the required virtual "fuse" in the system, and line tension can be set and controlled quite accurately. Accordingly, in event of an excessive load being induced during an escort tow, the winch will rapidly relieve the tension in the line to prevent a breakage and then recover line length to keep the relative position of tug to tow close to the same as initially defined. This brake slip capability must be fully controllable according to prevailing conditions and the rated loads of the fittings in use, and be fully reliable.

2.5.2 Electric Winches

There is currently a very distinct trend to electrically-driven winches in this arena. Electric winches have the following advantages:

- Mechanically efficient
- Very high initial torque available
- No polluting substances involved in their installation
- Line tension can be set from the bridge

- With appropriate control system design, variable winch loads will attenuate spike line loads, eliminating the risk of high force, line-parting incidents
- Low installation costs
- Low maintenance

Disadvantages are:

- Higher initial capital costs
- Generally higher weight than a hydraulic winch
- Higher onboard power generation capacity required

However experienced shipbuilders advise that an electric winch in the 200–300 hp range can be installed for about \$150,000 less than a hydraulic winch, a difference which in many instances would offset the capital cost differential. Finally, the maintenance costs for an electric winch are significantly lower than for a hydraulic winch and the risk of oil pollution is effectively nil, so in the long term of the tug's life an electric winch can demonstrate significant cost advantages.

2.5.3 Hydraulic Winches

Hydraulic winches once dominated the tug market. Two systems are used: high-pressure hydraulics (low volumes, high pressure and high flow rates), which is the most common in North America, and low-pressure hydraulics (large volumes, low flow rates and lower pressures), which is more common in Europe. The advantages of high pressure hydraulic winches are:

- Low weight on deck
- Very low moment of inertia (reducing the reaction time for rope tension changes)
- Simple and generally robust construction (although the latter very much depends on the manufacturer), and
- The price is reasonable

Low pressure winches are larger and heavier and require more power for the same performance, and require large bore pipes moving the fluid from pump to motor, but this winch type certainly has its devotees. A persistent problem with any hydraulic system is the need for absolute cleanliness in the piping and flow control systems. Any contaminants in the installation process or in the oil can lead to failed control components, and thus a great deal of flushing and cleaning of hydraulic lines is necessary. Leaks are inevitable.

2.5.4 Load Monitoring

All winches in modern escort tugs have various load monitoring features. The typical installation would include readouts for:

- Towline tension (measuring the actual force in the line when it reaches the drum; not any of the various performance critical force components.)
- Line length paid out

In addition the Master should be able to adjust the brake setting of the winch according to weather conditions or, in the most likely event, to match the reduced load rating of the fittings on the ship to which he must attach.

2.5.5 Line Management Devices

One of the major problems with escort towing winch operations has been the tendency for the line to "dive" or to "bite" down into the other line wraps on the drum in service, causing excessive wear or damage to the line. This happens when the line is wound onto the drum under zero or quite low tension, so that space opens up and the loose line compresses, permitting the line to dive under tension.

The reference material indicates that this was a source of early problems on the PRT Class tugs, and is often a problem elsewhere in the tug world. Solutions were tried on the PRT tugs including using a "Spectra" blanket between the working end of the towline and the lower layers, but that was apparently abandoned in favor of the system described in Section 1.1.2(e).

In order to address this problem however several winch manufacturers have developed spooling systems with a very coarse pitch which lays alternating layers of rope down diagonally over the layer below, thus precluding the potential for any biting down, even if the line is applied under relatively low tension, although that practise is not recommended. This type of spooling system is strongly recommended.

2.6 Escort Towline Technologies

2.6.1 General

Without question the escort towing industry has moved largely to the use of very high-strength High Modulus Polyethylene fibre (HMPE) towlines (sometimes referred to as UHMWPE; Ultra-High Molecular Weight Polyethylene; these are the same fibre, in spite of different acronyms).

HMPE fibre has the highest strength to weight ratio of any synthetic or natural fibre and has stretch characteristics similar to wire. It also floats due to its low specific gravity, which property greatly benefits tug operators when recovering slack lines, avoiding getting them caught in propellers, etc. The light weight also significantly simplifies the process of getting a line from a tug to a ship as the force required to haul up this smaller and lighter line is much less than with the much larger and heavier polyester lines of the same strength.

There are two major manufacturers of HMPE fibre:

- Honeywell (USA) which manufactures "Spectra®" Fibre, and
- DSM Dyneema B.V. (Netherlands), which manufactures "Dyneema®" fibre

Various companies feature these fibres in their rope products, including:

- Honeywell:
 - Puget Sound Ropes/Cortland (USA); "Spectra" and "Plasma" lines

- DSM/Dyneema:
 - Samson (USA); "Amsteel Blue" lines
 - Lankhorst (Netherlands), "Lankoforce" lines
 - Dynamica – Denmark
 - English Braid – UK

Rather surprisingly however, a number of operators still prefer to use the more elastic polyester lines for escort operations. This line is larger and heavier and has considerably more stretch, so two distinct philosophies emerge for escort towing:

- a. Use a high-strength, low stretch line and use a "dynamic" winch which can deal with all the dynamic loads imposed during operations, *or*
- b. Use a more elastic line and a (perhaps) somewhat simpler winch.

However to perform escort operations in compliance with most Class rules the winch must still be able to carry the full operating load on a dynamic braking system, and must have the capacity to release under a specified tension and then recover line under that same load. The arguments apply equally to lines which are monolithic in structure or where composed of a main line plus a "stretcher" (see Section 2.7.4).

In discussing this subject, Mr. Barry Griffin, the author of numerous papers on the topic of escort towing systems, offered the following comment:

"A dynamic winch responds to the hawser tension it measures, typically by monitoring sensors in the winch. Whether a stretcher is in the line or not it makes no difference to the basic function of the winch except that the stretcher attenuates the higher frequency energy, thus allowing the winch to operate at lower frequency – an advantage. The winch simply sees a different tension profile."

Representatives of Markey Machinery offered the following commentary on this topic:

Arguably the use of stretchers or lines with higher elastic properties is only advantageous when more capable winches are not present aboard the tug. While ropes with higher elastic properties can attenuate some snap loads, this characteristic comes with the disadvantages of uncontrollability, snap-back if a line breaks, and bulk:

1. *Uncontrollability: Simply refers to the issue of the operator having to deal with the elasticity of the rope in all modes of operation, even if not desired and regardless of the winch capabilities. When the winch offers line load attenuation and lines are used with very low elasticity, winches with higher performance Markey Render/Recover® allow the operator to simply dial-in the desired line tension, all the way to bollard pull ratings.*
2. *Snap-back: By the very characteristic of having higher elasticity, these types of ropes store energy that becomes dangerous when the ropes fail. The sudden release of this energy causes the rope to snap back to each end where the line is connected.*
3. *Bulk: Stretchy lines such as nylon and polyester are nowhere near as strong as HMPE lines. Consider comparing 80 mm diameter (Polyester) (424,889 lbs. MBF) with 80 mm diameter HMPE (1,045,400 lbs. MBF). Based on strength alone, imagine the size and weight savings of the winch if 80 mm diameter (polyester) were replaced with HMPE of similar strength, [which] in this case would be 52 mm diameter HMPE. This results in a 35% reduction in winch drum width plus a similar reduction in winch drum flange depth."*

Table 2.3 overleaf shows the data provided by respondents with respect to their escort towline systems in current use.

Table 2.4 following summarizes the critical characteristics of the most common towlines in use in the industry today, according to the responses received.

Table 2.3 Escort Towline Systems Data

Bollard Pull (tonnes)	Winch Maker	Model	No. of drums	Drum Capacity (metres)	Static Brake Rating (tonnes)	Dynamic (Escort) Holding Capacity (Tonnes)	Does the winch have a render/recover or constant tension mechanism? (yes/No)	Range of loads (in tonnes) that can be carried on rendering device	Max. rendering speed at max load	Max recovery load and speed	Length of Towline (metres)	Type of Towline	Any Stretcher? (Yes/No)	Length/Material of Stretcher	Any "Pennant" at outer end? (Yes/No)	Length (m) /Material of Pennant	Type of line protector used	Time interval to replace towline?	Time Interval to rotate (end -end) towline ?	Any standard procedure for line condition monitoring?	
83	Rolls Royce	TW2250/1000/AW26/U2H	2	-	225	100	Yes	8.4T---140T at 04 rendering speeds	140T at 0--12m/min	100T at 0---10m /min	150	Lankoforce (Dyneema)	Yes	25m Euroflex	Yes	20m Euroneema	defender	under supervision	under supervision		
8.5	Rolls Royce	TW2250/1000/AW26/U2H	2	-	225	100	Yes	8.4T---140T at 04 rendering speeds	140T at 0--12m/min	100T at 0---10m /min	150	Lankoforce (Dyneema)	Yes	25m Strongline	Yes	20m lankoforce	defender	under supervision	under supervision		
83	Rolls Royce	TW2250/1000/AW26/U2H	2	-	225	100	Yes	8.4T---140T at 04 rendering speeds	140T at 0--12m/min	100T at 0---10m /min	150	Lankoforce (Dyneema)	Yes	25m Strongline	Yes	20m lankoforce	defender	under supervision	under supervision		
83	Rolls Royce	TW2250/1000/AW26/U2H	2	-	225	100	Yes	8.4T---140T at 04 rendering speeds	140T at 0--12m/min	100T at 0---10m /min	150	Lankoforce (Dyneema)	Yes	25m Strongline	Yes	20m lankoforce	defender	under supervision	under supervision		
65	C.KRAAIJEVELD B.V	W30-H-TR-22D/22D KA30-H-TR	2	-	175	175	-	-	-	-	150	Samson (HMPE)	Yes	20m Turbo37	Yes	20m amsteel blue	cordura	under supervision	under supervision		
65	C.KRAAIJEVELD B.V	W30-H-TR-22D/22D KA30-H-TR	2	-	175	175	-	-	-	-	150	Lankhorst (HMPE)	Yes	20m Strongline	Yes	20m lankoforce	defender	under supervision	under supervision		
84	Karmoy Winch	60566	2	-	200	100	-	-	-	-	150	Samson (HMPE)	Yes	20m superstrong	Yes	20m amsteel blue	cordura	under supervision	under supervision		
84	Karmoy Winch	60566	2	-	200	100	-	-	-	-	150	Lankhorst (HMPE)	Yes	20m Strongline	Yes	20m lankoforce	defender	under supervision	under supervision		
84	Karmoy Winch	60566	2	-	200	100	-	-	-	-											
84	Karmoy Winch	60566	2	-	200	100	-	-	-	-											
65	DATA Hydraulic	DTW 45x130 HZ	2	-	130T	45	-	-	41.7 m/min	-	120	Lankhorst (HMPE)	No	N/A	Yes	20m lankoforce	defender	1500 jobs			
72	Markey	DEPCF-50	1	150	235	72	Yes	22 ton	20'/min	72 ton @ 20'/min	91	Plasma 12-strand	No	n/a	Yes	200' PLASMA 12strand	N/A	condition/use inspections	2-2.5 years	yes	
90	Karmoy	-	-	-	as per ISO rules	150	Yes	all loads	-	-	200	HMPE	YES	Polyprop	no	HPME	HPME	4-5000 jobs	2000 jobs	yes	
75	Karmoy	-	-	-	as per ISO rules	100	Yes	-	-	-	200	HMPE	YES	Polyprop	no	HPME	HPME	4-5000 jobs	2000 jobs	yes	
75	Karmoy	-	-	-	as per ISO rules	100	Yes	-	-	-	200	HMPE	YES	Polyprop	no	HPME	HPME	4-5000 jobs	2000 jobs	yes	
90	Karmoy	-	-	-	as per ISO rules	150	Yes	-	-	-	200	HMPE	YES	Polyprop	no	HPME	HPME	4-5000 jobs	2000 jobs	yes	
65	Karmoy	-	-	-	as per ISO rules	150	Yes	-	-	-	200	HMPE	YES	Polyprop	no	HPME	HPME	4-5000 jobs	2000 jobs	yes	
50	Karmoy	-	-	-	as per ISO rules	100	Yes	-	-	-	200	HMPE	YES	Polyprop	no	HPME	HPME	4-5000 jobs	2000 jobs	yes	
90	Karmoy	-	-	-	as per ISO rules	150	Yes	-	-	-	200	HMPE	YES	Polyprop	no	HPME	HPME	4-5000 jobs	2000 jobs	yes	
70	Karmoy	-	-	-	as per ISO rules	130	Yes	-	-	-	200	HMPE	YES	Polyprop	no	HPME	HPME	4-5000 jobs	2000 jobs	yes	
78	Ridderinkhof	AMW-H-300-98-8151	3	2*250, 1*650	300	-	No	-	-	30 MT 1st layer 30m/min	650	56 mm steelwire	Yes	115mm polyester	Yes	Dyneema		5 years	no rotation	Visual each job	
65	Plimsoll	HTW/SD30/150-ir	1	450	150	-	No	-	-	30 MT 1st layer 30m/min	160	76mm polyester	No		Yes	Dyneema		2-3 years	1 Y/1 Y dubble	Visual each job	
84	Plimsoll	P4360HTW/DD-30/200	2	1*250, 1*650	200	-	No	-	-	30 MT 1st layer 30m/min	180	80mm polyester	No		Yes	Dyneema		2-3 years	1 Y/1 Y dubble	Visual each job	
81	Plimsoll	P4360HTW/DD-30/200	2	1*250, 1*650	200	-	No	-	-	30 MT 1st layer 30m/min	180	80mm polyester	No		Yes	Dyneema		2-3 years	1 Y/1 Y dubble	Visual each job	
80	Burrard Iron	HJ	1	300	150t	40	yes	5/20/40	20 m/min	20 m/min	250	3 1/4" Amsteel	No	N/A	No	N/A	Dyneema Cover	3 1/2 to 4 years	10mos(cutback)	Visual Inspection	
70	Rolls Royce	TW 2000/500	1	245	200t	80	yes	0-80t	0-20 m/min	50t @ 0-18 m/min	200	2 3/4" Q12	No	N/A	No	N/A	Dyneema Cover	3 1/2 to 4 years	10mos(cutback)	Visual Inspection	
70	Rolls Royce	TW 2000/500	1	245	200t	44	yes	0-80t	0-20 m/min	50t @ 0-18 m/min	200	2 3/4" Q12	No	N/A	No	N/A	Dyneema Cover	3 1/2 to 4 years	10mos(cutback)	Visual Inspection	
80	Rolls Royce	TW 2000/500	1	245	200t	44	yes	0-80t	0-20 m/min	50t @ 0-18 m/min	200	3" Amsteel	No	N/A	No	N/A	Dyneema Cover	3 1/2 to 4 years	10mos(cutback)	Visual Inspection	
80	Rolls Royce	TW 2000/500	1	245	200t	44	yes	0-80t	0-20 m/min	50t @ 0-18 m/min	200	3" Amsteel	No	N/A	No	N/A	Dyneema Cover	3 1/2 to 4 years	10mos(cutback)	Visual Inspection	
100	Plimsoll	PC-HTW/SD 80/150	2	300	250	50	Yes	10-50 tonnes	-	-	300	64mm Dyneema	No							Visual Check	
100	Plimsoll	PC-HTW/SD 80/150	2	300	250	50	Yes	10-50 tonnes	-	-	300	64mm Dyneema	No								Visual Check
100	Plimsoll	PC-HTW/SD 80/150	2	300	250	50	Yes	10-50 tonnes	-	-	300	64mm Dyneema	No								Visual Check
100	Plimsoll	PC-HTW/SD 80/150	2	300	250	50	Yes	10-50 tonnes	-	-	300	64mm Dyneema	No								Visual Check
78	Kraaijeveld	KASSO-H-TR-24D	2	130	250	60	Yes	10-60 tonnes	50t x 28.8m/min	44t x 27.4m/min	200	48mm Dyneema	No		Yes	25m Dynnema				Visual check	
78	Kraaijeveld	KASSO-H-TR-24D	2	130	250	60	Yes	10-60 tonnes	50t x 28.8m/min	44t x 27.4m/min	200	48mm Dyneema	No		Yes	25m Dynnema				Visual check	
78	Kraaijeveld	KASSO-H-TR-24D	2	130	250	60	Yes	10-60 tonnes	50t x 28.8m/min	44t x 27.4m/min	200	48mm Dyneema	No		Yes	25m Dynnema				Visual check	
78	Kraaijeveld	KASSO-H-TR-24D	2	130	250	60	Yes	10-60 tonnes	50t x 28.8m/min	44t x 27.4m/min	200	48mm Dyneema	No		Yes	25m Dynnema				Visual check	
65	Plimsoll	-	2	150	130	-	No	-	-	80t x 3.5m/min	300	52mm Dyneema	No		Yes	25m Dynneema				Visual check	
65	Plimsoll	-	2	150	130	-	No	-	-	80t x 3.5m/min	300	52mm Dyneema	No		Yes	25m Dynneema				Visual check	
65	Plimsoll	-	2	150	130	-	No	-	-	80t x 3.5m/min	300	52mm Dyneema	No		Yes	25m Dynneema				Visual check	

Table 2.4 Summary of Common Towline Critical Characteristics

MAJOR TOWLINES CURRENTLY IN USE WORLDWIDE										June 2012
<i>Data from Manufacturer's Literature</i>										
Brand Name	Manufacturer	Fibre	Diameter	Weight/100 metres	Tensile Strength (MBF)	Elongation at 40% load	Elongation at Breaking Strength	Melting Point	UV Resistance	Coeff. Of Friction
			<i>mm</i>	<i>kG</i>	<i>kN</i>	<i>%</i>	<i>%</i>	<i>degrees C</i>		
Plasma 12 Strand	Cortland Puget Sound Rope Corp.	Honeywell "Spectra"	72	318.5	3470	~1.5%	4-5%	140	moderate	0.09-0.12
			76	349.7	3781					
			80	388.4	4181					
Polyester "Double Braid"	Cortland Puget Sound Rope Corp.	Polyester	72	447.9	1054	~8.5%	15-20%	250	excellent	0.12-0.15
			80	526.8	1299					
			88	654.8	1548					
Amsteel Blue	Samson Rope Technologies	Dyneema	56	173	2148	< 1%	??	??	??	??
			76	339	3689					
			82	360	4483					
Quantum 12	Samson Rope Technologies	Dyneema	56	149	1795	< 1%	??	??	??	??
			72	266	3227					
Lankoforce	Royal Lankhorst Euronete Group BV	Dyneema	48	126	1853	1.90%	3.50%	147	excellent	?
			52	149	2160					
			64	230	3210					
Strongline	Royal Lankhorst Euronete Group BV	Polyester	76	390	1730	9%	15%	265	excellent	?
			80	417	1890					

2.7 Towline Composition

2.7.1 Main Towlines

Of the 38 vessels described in the responses, only 4 use other than an HMPE towline. Three of those use polyester, and one vessel (used primarily in harbour work) uses a steel towline. The latter is considered an anomaly in the industry and will not be accounted for in further discussions of this topic.

Towlines based on Dyneema® dominate the sample, largely due to the apparent greater number of rope manufacturers using that fibre as opposed to those using Spectra®, and the fact that the majority of respondents were from Europe and the Middle East where the Dyneema® product dominates the market.

2.7.2 Towline Characteristics

Annex G, extracted from the Samson Rope catalogue, contains a summary comparison of the critical characteristics of virtually all the basic fibres used in synthetic rope construction.

2.7.2.1 Strength

HMPE fibre lines have equal or greater strength than steel wire rope on a direct size (diameter) comparison. There is some strength to size variation among the various ropes manufactured but that range is not great.

Figure 2.1 (below) illustrates the comparative strength (advertised mean breaking strength) of all the towlines cited in the sample as a function of diameter and line type. This clearly illustrates the superior strength characteristics of the HMPE lines, which fall into a fairly narrow band depending upon the type of line and the nature of the braiding. The data suggests that the "Lankoforce" lines are the strongest per size of any of the HMPE lines available, but this survey is not exhaustive and hence that conclusion may not stand up to detailed scrutiny. The only reliable data for line strength must be obtained from certificates of actual breaking strength which are normally supplied with each line and which should reflect industry standard test procedures. Current standard is to report the "Minimum Spliced Breaking Strength" which should be supported by actual test certificates. If common procedures are followed then it is logical that there should be less variation in line strength, as the basic fibre elements are essentially identical and the only differences are in the braiding and splicing geometry.

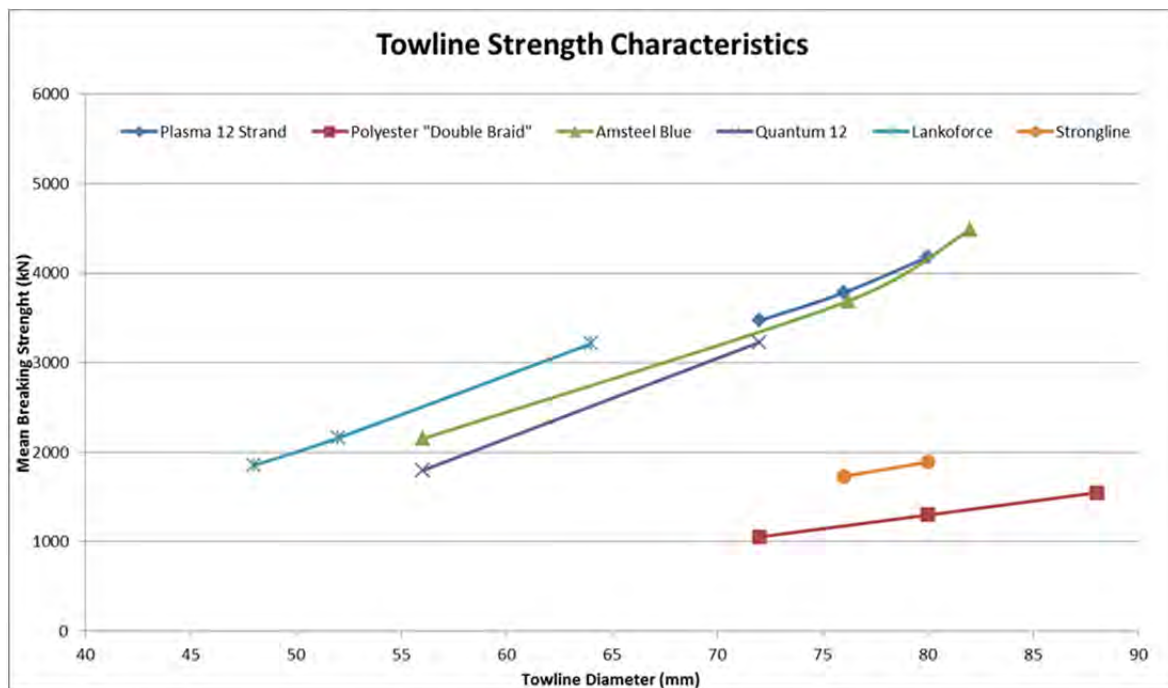

Figure 2.1 Towline Strength Characteristics

2.7.2.2 Weight

As mentioned, the weight of HMPE lines is significantly lighter than polyester and certainly much lighter than steel on an equal strength basis, which makes line handling easier and safer. These lines float, enabling tug operations to be much simpler and safer, with reduced risk of fouling propellers, etc.

2.7.2.3 Elongation

HMPE lines have very little elongation (or "stretch"), and thus in the event of a line failure there is virtually no recoil, leading to a safer working environment for the crew on deck and in the wheelhouse. However HMPE lines can still display a "whiplash" reaction in failure so crews should not be lulled into a false sense of security with these lines.

This lack of extension can lead to high snap loads in the towline of an escort tug, particularly when working in high seas. Accordingly means must be provided in order to reduce the peaks in line tension experienced during these dynamic events. The obvious means of accomplishing this are (a) the use of dynamic winches as discussed in Section 5, and/or (b) the use of more resilient "stretchers" in the towline system.

2.7.2.4 Abrasion Resistance

The vulnerability of HMPE lines is their low abrasion resistance. Manufacturers distinguish between external abrasion and internal abrasion, the latter caused by relative movement of internal and external yarns. The following extract from the Samson Ropes catalogue [12] captures the essence of the issue well:

"There are two types of abrasion: internal abrasion caused by the relative movement of internal and external yarns, and external abrasion caused by contact with external surfaces. An unprotected rope moving over a rough surface, such as a poorly maintained chock can be subjected to both. Upon inspection, it's easy to see that the external strands are abraded by a rough surface: often, fibers can be left behind on the surface that caused the abrasion, and the surface of the rope readily shows abraded yarns.

The same rough surfaces can also cause internal abrasion due to the movement of the internal strands relative to each other. When the rope's surface strands pass over rough surfaces, they are slowed relative to the strands next to them, causing friction. Heat is created from friction—and heat is among the biggest enemies of synthetic ropes.

Fortunately, the effects of both types of abrasion are easily mitigated. Proper surfacing of hardware is easily addressed. Grinding and smoothing of surfaces prior to the installation of synthetic ropes is standard procedure ... and hardware specifically made for use with synthetic ropes is also available. Because lines are often subjected to surfaces not under your control, like mooring bollards roughened and scored by wire ropes, proper chafe gear is essential."

Accordingly nearly every manufacturer offers a form of open weave chafing protection, such as the "Dynalene" chafe protection manufactured by Samson, illustrated in Figure 2.2 below.



Figure 2.2 Typical Chafe Protection Gear for HMPE Towlines (ref. SamsonRope.com)

2.7.2.5 Fatigue

Escort tug towlines experience fatigue in two ways; one in direct tension cycling, and the other in the cycles of bending around the various towing fittings encountered. In order to extend rope life, the latter should be designed to minimize the bend radius which ropes encounter. Tension fatigue can be mitigated by use of an appropriate rendering device.

2.7.2.6 Heat Resistance

As noted in Section 2.7.2.4 above, heat resistance is another weakness of synthetic lines. Ropes can be subject to high ambient temperatures (not an issue in Alaska!), but most critically from the heat generated by the friction generated between lines and fittings, and by the internal friction generated within the rope under tension. This problem can be mitigated to a degree by water lubrication of the contact points, and of course by using very highly polished low-friction surfaces on the towing fittings.

2.7.2.7 Ultra-Violet Resistance

Some synthetic lines are susceptible to ultra-violet (UV) degradation (particularly polyethylene and polypropylene) and may suffer severe weakening from prolonged UV exposure. Some lines are treated with pigments or stabilizers to reduce this effect. These effects can be mitigated by simple protective covers on the lines when they are not in use. In general however HMPE lines will wear and be ready to retire long before any UV damage has a marked effect on line strength. The exception would be long term line storage in an exposed location or use in full tropical sun conditions.

2.7.2.8 Chemical Reactions

Industry representatives advise that a relatively serious problem is the accidental exposure of working lines to "Limnolene", the common orange cleaner often used on ships. This cleaner is a strong oxidizer and if spilled full strength on an HMPE line will reduce its strength significantly. Clearly crews should be advised of this risk.

2.7.3 Line Inspection and Maintenance

The strength characteristics of all components in a system are based generally on "as new" conditions. As line strength has been well-documented to deteriorate with use, due to both fatigue and by abrasion, it is clearly important to monitor line condition to ensure that the line is capable of carrying its design load. Figure 2.3 below illustrates residual strength data compiled by Samson Ropes with three of their major Clients (including the Crowley SERVS vessels). This clearly illustrates that after approximately 1,000 uses (which might be 1-2 years of use (or less) depending on the vessel), the towline has only 40-50% of its advertised initial strength.

Field Trial Results

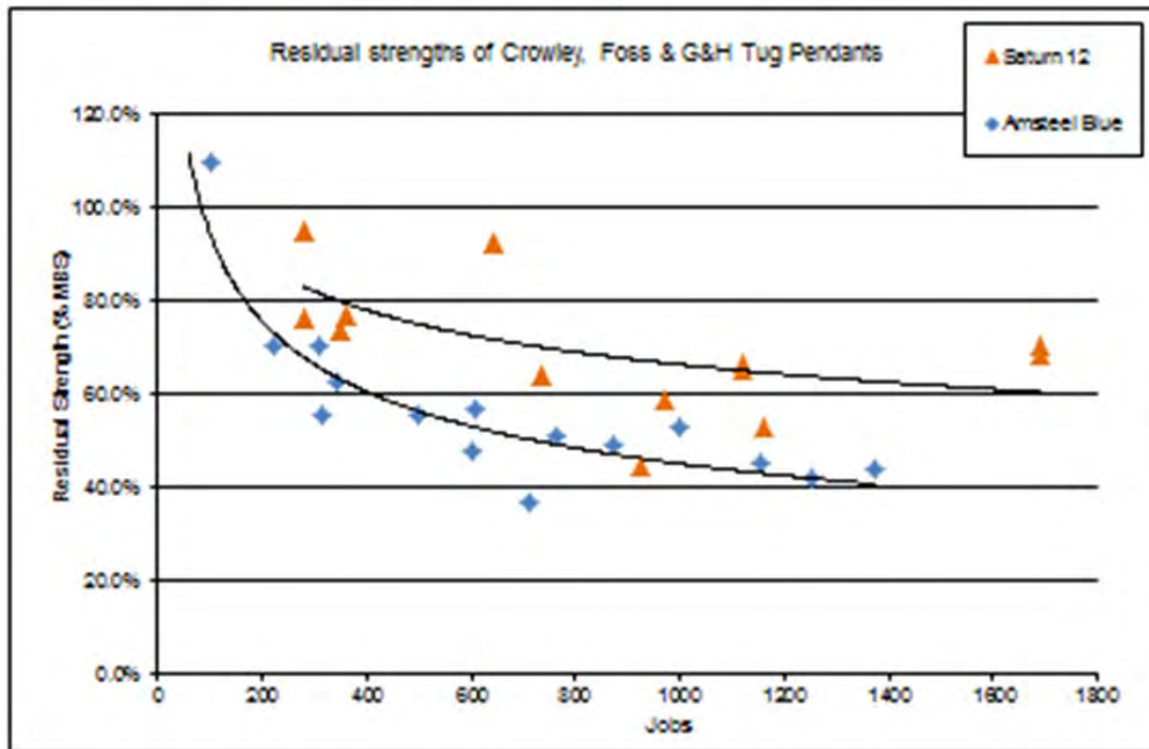

Figure 2.3 Residual Strength Data (Courtesy of Samson Ropes)

The following are techniques common in the industry to extend line life and ensure high strength maintenance:

- Line Rotation: Turn the towline end-for-end after a specified number of jobs. This moves the abraded outer end onto the drum end so that any abrasion effects are spread over the full length of towline.
- Cut-backs: Some operators cut back line length, taking off say the outer 20–25 metres of towline after a set interval of working. This is another method to spread the chafing load over a greater percentage of the towline.
- Inspection Routines: Virtually all respondents indicated some formal process in place to monitor line condition, and many do visual checks on every job.

- Testing: None of the respondents indicated specifically that they use any form of either destructive or non-destructive testing to assess the condition of lines in active service. However Samson Ropes provided extensive details about the processes used in concert with Crowley to carefully monitor line strength on the SERVS tugs. This same process of extensive line data monitoring and analysis is in regular use by many towing companies, and it is common for oil majors to demand such data when evaluating towing contract proposals.

Another fairly typical device used to reduce line wear is to fit a sacrificial "pennant" (or often "pendant") at the outer end of the towline. As this is where most of the mechanical damage occurs to a line (through contact with bits, fairleads, chocks, etc.), the fitting of a length of about 20–25 metres of sacrificial line (incorporating the outer eye splice) is a sensible way to reduce the frequency of main towline replacement. Typically this pennant is of the same type of line as the main towline.

2.7.4 Stretchers

The impact of use of stretchers was discussed in Section 2.6.1 above. Of the tug operator respondents, 44% use stretchers, while the remaining 55% do not.

Among those using stretchers, the typical choice is some form of polyester or polypropylene, and 20–25 metres is a typical length.

2.7.5 Connections

The published data for line strength etc. can either be based on straight sections of new line or on the "as-spliced" condition. As virtually all lines used in escort tug operations incorporate an eye splice at the outer end, and often also in the connection between the main line and stretcher or pennant it is critically important when comparing lines to ensure that the method of determining mean breaking strength is the same, and ideally that it reflects the as-spliced condition.

Knots are another issue: line strength can be significantly reduced due to the tight bend radius used in knots. Some lines can lose up to 50% of their strength in knots. Accordingly the use of any knots in a towline system should be avoided.

The most common method of joining sections in a towline is what the industry typically refers to as a "cow hitch", as illustrated in Figure 2.4 below:



Figure 7.4 "Cow Hitch"

This figure illustrates the typical use of this style of hitch to connect a rope to a fixed object (like a rail or ring), but it obviously can be used to connect two bights as illustrated below (Figure 2.5). This however does impose the equivalent of a knot in the towline which must be factored in the overall line strength. According to the OCIMF "Guidelines" [5] this joining technique reduces the line strength to about 85% of the original. Apparently this type of connection is more common in Europe than in North America, where an eye-to-eye or "spectacle splice" is more commonly used.

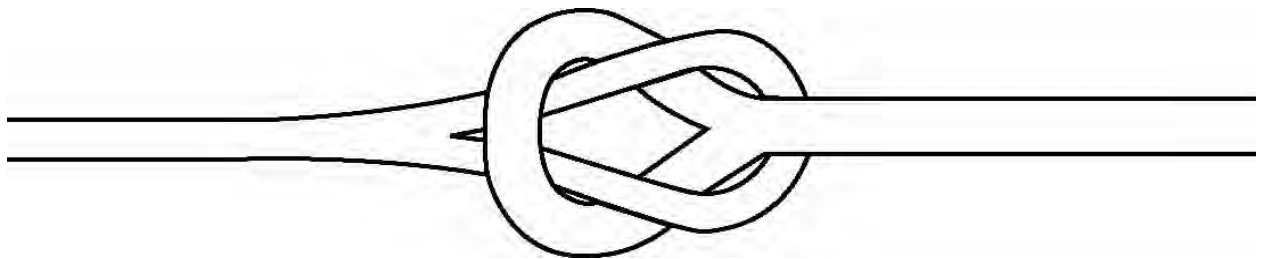

Figure 2.5 "Cow Hitch" Connecting Two Bights

Lankhorst Ropes developed a unique method of making eye splices much stronger [12], by putting the spliced material into the bight of the rope rather than into the standing part. This reduces the wear on the hardest working part of the line, and according to the manufacturers reduces or eliminates the point of maximum stress in the line.

2.7.6 Chafing Protection

Of the respondents, 58% fit chafing protection to their towlines and typically the protection is made of some form of HMPE fibre (as previously shown in Section 2.7.2.4).

Samson Ropes provided data (Figure 2.6) illustrating the beneficial impact that chafing protection has on the lifespan of towlines.

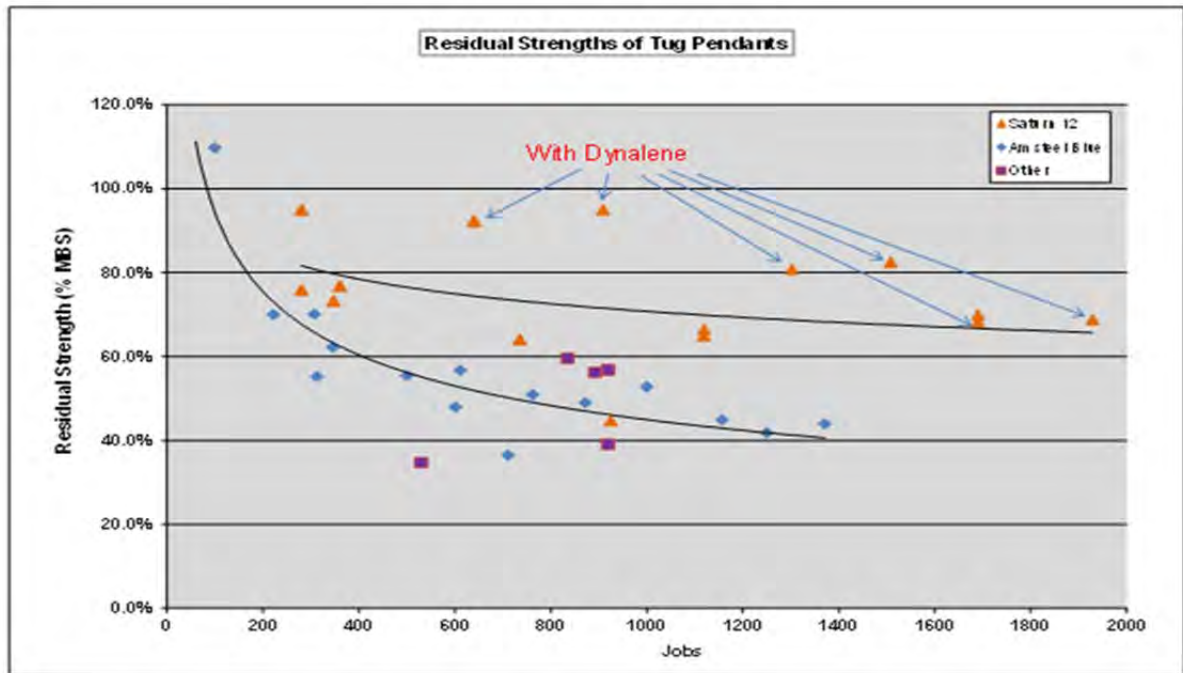

Figure 2.6 Impact of Chafing Protection on Lifespan of Ropes

Table 2.5 (ref. Samson Ropes) below summarizes the impact of chafing gear on towline residual strength. Clearly there are distinct if not essential benefits from the use of such gear.

Table 2.5 Impact of Chafing Gear on Towline Residual Strength

	WITH	WITHOUT
Average # of Jobs	622	659
Average Residual Strength (% Published MBS)	64%	42%
Remaining Safety Factor	3:1	2:1

Figure 2.6 above also illustrates how rope strength deteriorates quite significantly with use, albeit less dramatically when protected. Surface lubrication, usually by water spray, is another simple means to reduce friction between the towline and the towing fittings.

2.7.7 Towline Strength vs. Power (BP vs. Rope Strength (BS))

Figure 2.7 illustrates the ratio of tug thrust (Bollard Pull) to the mean breaking strength (MBS) of the towlines fitted within the sample of tugs evaluated. The results are rather surprising in that there are more tugs in the lower end of this MBS/BP range than one would have expected. It is widely considered that the minimum ratio should be 3.0 for regular ship-handling service and for escort service values of 4–5 or more are more common. It is worth noting that the lowest values are those associated with the polyester lines, which may reflect the fact that these lines are larger and hence harder to stow on a reasonable size of winch, and thus the tendency is to use a smaller, lighter line than might otherwise be required.

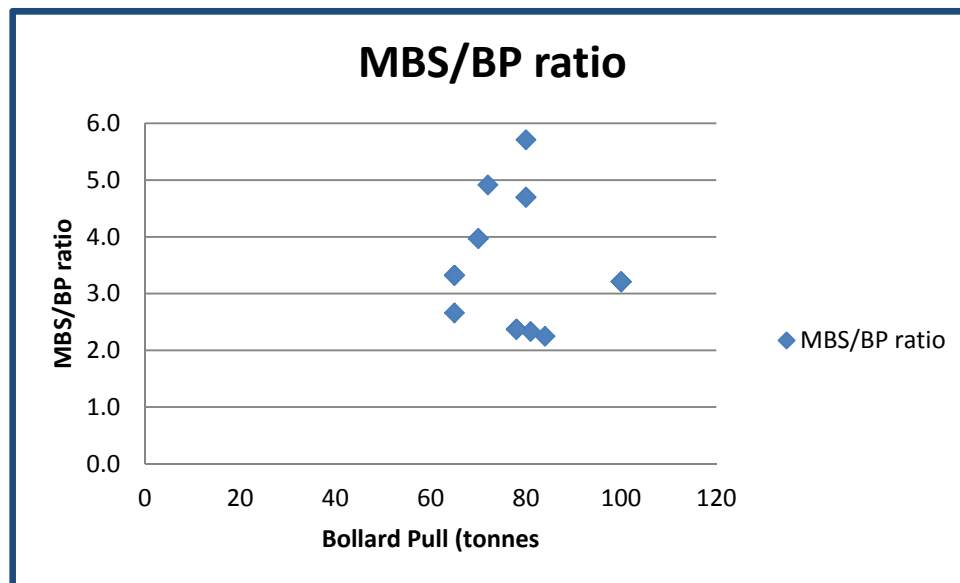

Figure 2.7 Ratio of Tug Thrust (Bollard Pull) to Mean Breaking Strength

It is important in selecting a line for escort service to consider the full extent of operating conditions and lead angles, and to ensure that the line strength at the "end of line life" satisfies the minimum strength requirements of Class or other authorities. On this basis a minimum MBS/BP ratio of 5:1 is very easy to justify as follows:

- Assume the minimum required Design Factor of Safety (DFOS) is 3:1, which allows for static bollard at a 60° up-angle in close-in assist, and a 2.5:1 DFOS for indirect escort assuming low vertical line leads. Line tension can reach 2 x BP
- Assume the line will lose 30% of its strength during service, therefore to have 3:1 at retirement you need to start at 4:1 (1.3 x 3.0 = 3.9)
- Add 1 or 2 DFOS for 5:1 or 6:1 if dynamic seas predominate

2.8 Towing Fittings

2.8.1 Ship Fittings

The comments received from tug operators were almost universally in agreement that the major source of failures in the towing gear was poor fittings on the attended ship. Examples of comments received are:

"The ONLY towline failure we have encountered was due to a cut in the line on a ship's "knife edge" or quarter that had occurred on the job. Other than that our inspection of line on a daily basis and repairs done as needed has kept our line failures to a minimum."

"The tow line on board the vessel (tanker) was in contact with sharp edge out of sight from tug, line parted."

"In case of a towline failure or damage, it is often in the ships fairlead."

Unfortunately the design and configurations of ship's fittings are not generally under the control of the tug operator or a tug designer. Tug operators need to work through OCIMF and similar agencies to improve communications on this critical subject.

However it is noteworthy that in Prince William Sound the total tanker-tug system is extremely well integrated and the tanker fittings are designed to be fully suitable for the line force generation capability of the specific tugs within the SERVS system. The TAPS system is therefore an excellent model to other operators in the worlds of how escort tugs and tankers should be designed to be fully compatible.

2.8.2 Tug Fittings - Static

Although there are means to protect the towline from damage as described in Section 2.7.2.4 above, the design of the towing fittings on the tug itself is a major factor in ensuring better rope performance and life. The majority of fittings used in escort service are rigid and static structures such as those illustrated in Figure 2.8 below. There are many variations on this theme, some "O" shaped, some "A" shaped, and some with very elongated slots. These devices are variously called "Bits" or "Staples" or "Fairleads". The common characteristic is (or should be!) robust construction, and a large diameter bending contact surface, and a highly polished surface for rope contact. It is common today to analyze the strength of such fittings using advance analytical techniques of Finite Element Analysis (FEA) to verify that all elements of the staple and its supporting structure are adequately designed for the high escort loads. An example of such an FEA model is shown in Figure 2.9.

Figure 2.8 Examples of Types of Towing Staples in Use:



a. Wide Slotted Staple with Upper Wire Fairlead



b. Annular Fairlead



c. "A" Form Staple with Aft Bending Supports



d. Double Aperture Staple

Figure 2.9 FEA Models of Escort Towing Staples:

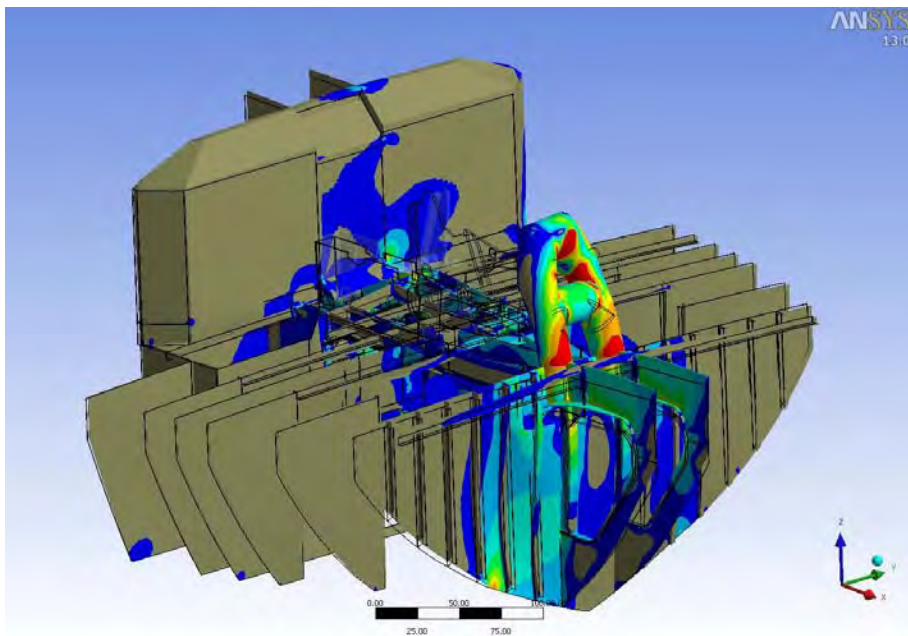

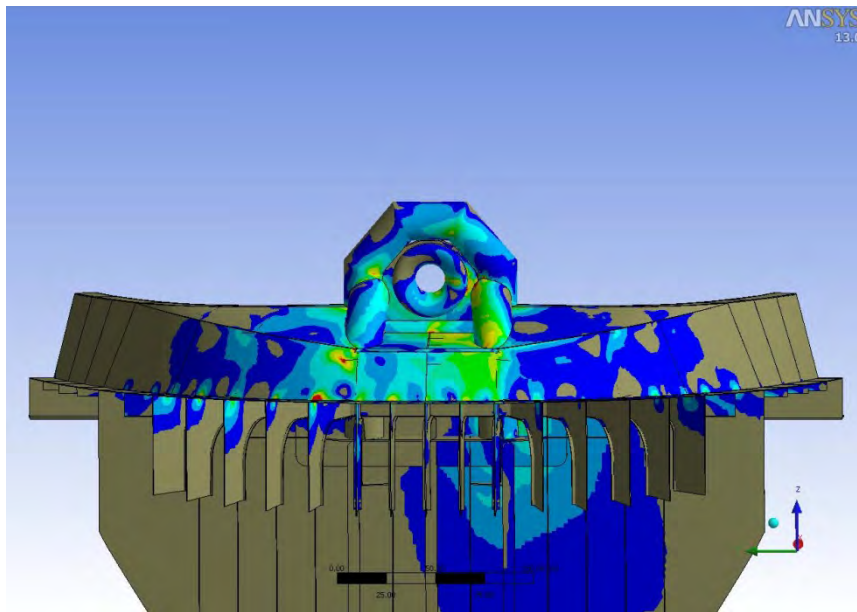

These tug fittings are completely within the control of the designer and the shipbuilder, and hence to some degree even the tug Owner, yet even here the failure of fittings is not that uncommon. The photo in Figure 2.10 below illustrates a failure on a tug working in San Francisco, performing escort duties for which the tug fittings were clearly not suitably designed (notably none of these failures were on tugs designed by this company!).



Figure 2.10 Failure of a Badly-Designed Towing Staple

The critical design elements to consider are:

- Bend Radius: Suppliers advise that "*the static bend radius on 12 strand HMPE ropes has a relationship that approaches 1.0x the single leg rope strength as the bend decreases below a 1:1 ratio of bend diameter vs. rope diameter*". This suggests that rope strength is not seriously affected by bend radius until that radius is about the diameter of the rope. Other factors come into play however, including the general bending strength of the structure and the "hoop stress" experienced by the structure when the line bends around the surface. It is common to see lines "melted" by the combination of heat and pressure generated under such conditions, and also not uncommon to see the towing fitting itself damaged by the compressive strength of the rope. OCIMF in "Recommendations for Ship's Fittings for Use with Tugs" [6], provides the following comment on this topic:

"The minimum bending diameter for such ropes is typically 10 times rope diameter for plaited lines and 8 time rope diameter for braided lines."

which leads to a rather different conclusion concerning the size of escort towing fittings.

- Surface Finish: Samson recommend a surface finish of 300 micro-inches for any deck hardware surface that comes in contact with HMPE ropes (in an escort operation)

2.8.3 Towing Fittings – Active

Over the years a number of devices have been proposed to enhance the escort performance of tugboats. To date none of these have been installed in anything more than test vessels and have not been met with any noticeable enthusiasm by the tug owning community. The simplicity of a static structure is a distinct benefit in tug operations, and reduces the complexity of the entire operation.

The following are some examples of the types of active devices offered:

- a. Towliner: [7] - a horseshoe shaped device leading the hawser to the side of the tug on which the force is being applied and thus offering a righting moment to the tug, in the same manner as a radial arm tow hook.
- b. Mampaey Dynamic Oval Towing DOT System: [8] - this system consists of an oval shaped rail which effectively circles the tug, integrated into the tug's structure with a free moving carriage on the rail supporting the towing hook. The towline however is fixed in length, hence has no rendering capability.
- c. Carrousel Tug: [9] - The Carrousel is based on the same principle as a radial hook, but is extended to the full tug's width, encircling the deckhouse in a full circle. The designers of this system claim that the Carrousel ring allows the towing hook or winch to rotate freely without limitations. An existing tug was retro-fitted with the Carrousel system: Multirship Towage & Salvage's *Multratug 12* was chosen as the test tug to receive the first Carrousel system and testing of the new design was completed in 2002. To date it is not evident that any further applications have been installed.

- d. JonRie "Auto-Position Escort Winch": [10] - this recently introduced concept features a new form of winch mounting that enables the winch and its integral fairlead to rotate about a vertical axis and follow the line of force of the towline (Figure 2.11). The device has only been tested at model scale.



Figure 2.11 JonRie "Auto-Position Escort Winch"

- e. Kotug "Friction-Free Towing Device": [11] - At ITS 2012 the inventors of the Rotor Tug introduced this new device claimed to reduce rope wear and improve tug stability in escort operations. The device is claimed to prevent tow line failures from chafing against a tugboat's fixed towing point.



Figure 2.12 Kotug "Friction-Free Towing Device"

The device is mechanically complex, as illustrated in Figure 2.12 above.

2.9 Comments—Best Available Technology

The information summarized in this section represents the current escort towing equipment in use in a series of escort tugs, nearly all of which have been built in the past ten years. Accordingly it could be said to represent the "state of the art" as selected by prudent operators, but selecting the various components from among those in use to be nominated as "Best Available Technology" (BAT) is difficult, primarily because BAT will undoubtedly vary according to the location and the environment in which the tugs operate. However the following are what, in the opinion of the tug industry respondents, constitutes BAT in the industry today:

- Electric winches with high-speed render-recover capability
- HMPE towlines: various types were cited

The subject of BAT will be further discussed in the next section of this report.

2.10 Summary

The data collected is considered to be quite representative of the escort towing systems in use worldwide, although several key industry companies failed to respond within the requested time frame. In some instances that data has been added based on internal data where the vessels in question are part of the Robert Allan Ltd. design portfolio, however we cannot be certain that the gear currently fitted was exactly as originally specified. Note that the information collected was restricted to vessels in "active" escort service duty worldwide and not simply ship-handling.

The following are the most salient aspects of the information collected:

1. A significant majority (approx. 90%) of operators use HMPE towlines for escort work rather than the more elastic polyester lines, although some operators still prefer the latter.
2. A very few winch designer/manufacturers worldwide have developed the very high-performance winches that can provide the dynamic response necessary for a winch to pay out/recover a towline under high load at high speed as is required for many escorts.
3. In spite of having high performance winches, slightly less than half of operators still prefer to have a stretcher in the towline system.
4. Escort tugs typically use towlines with a breaking strength at least 4 times the static BP of the tug.
5. The vast majority of tugs use relatively simple static towing fittings as line fairleads, rather than any of the various active systems which have been conceived.

PART 3.0 BEST AVAILABLE TECHNOLOGY

3.1 Winch Specifications vs. Class Rules

The various Classification Societies each have slightly different (but also generally similar) requirements for winches on tugs rated for Escort Service. Table 3.1 below identifies the requirements of all of the major IACS members.

Table 3.1 Towing Gear Requirements per Class Rules

Description		American Bureau of Shipping (ABS)	Bureau Veritas (BV)	Det Norske Veritas (DNV)	Germanischer Lloyd (GL)	Lloyd's Register of Shipping (LR)	Safety Guidelines for Design, Construction & Operation of Tugs: A Harmonized Class Approach V1.9
Towing/Anchor Handling Equipment	Reference Load	Towing: Reference Load (RL) = 2 X BP (BP <= 50 Ltf), 1.33 X BP (BP >=150 Ltf) and interpolated between.	Towing: T= Bollard Pull (kN), Testing Force CT = 2 X T (T < 400), T + 400 (400 <= T <= 1200), 1.33 X T (T > 1200)	Towing: Reference Load (RL) = 3 X BP (BP < 40 t), 3.8 - BP/50 (40t <=BP <= 90t), 2 X BP (BP > 90t).	Design force T (kN) is towline max tension or BP. Test force PL = 2 X T (T <= 500), T + 500 (500 < T < 1500), 1.33 X T (T > 1500).		Design Load defined based on Max static Line tension and a Dynamic Application Factor based on service
Towing/Anchor Handling Equipment	Towing point location	Towline from as low as possible & close to but abaft of vessel CG.		Tow from near midlength of vessel and to minimize heel. Line feed (direction) to winch to be controlled and to allow spooling for all conditions.	Tow hook: as low as possible to minimize danger of capsize and attachment point closely behind the centre of buoyancy.	For over the stern towing, connection should be 5 to 10% abaft midships, never forward of 5% the ship's rule length abaft CG for any loading. Attachment as low as practicable.	Towline attachment to minimize heeling Towline sweep to be constrained to design limits
Towing/Anchor Handling Equipment	Towline breaking strength - Towing operation	Towing: Towline breaking strength >= RL. Towline constrained to design limits over the stern (with fairleads).			Towline minimum breaking strength Fmin >= 2.5 X T (T <= 200 kN), >= 2.0 X T (T >= 1000 kN).	Towline >= 2 X BP.	Towline strength > design load
Towing/Anchor Handling Equipment	Towline breaking strength - Escort operation	Escort (additional): Towline breaking strength >= 2 X BP	Escort (additional): T = Bollard Pull (kN), Towline breaking load >= SF X T with SF = 3 (T <= 600), 6-0.005T (600 < T <= 800), 2 (T > 800)	Escort (additional): Towline breaking strength >= 2.2 X maximum mean line tension.			
Towing/Anchor Handling Equipment	Towing equipment/structure design limits - Towing operation	Towing equip no permanent deformation at RL. Supporting structures withstand RL with horizontal load and up to 30 deg off CL to : normal stress <= 0.75Y, shear stress <= 0.45Y	Supporting structures with CT to: Von Mises stress <= 0.78Y and Shear Stress <= .51Y	Supporting structure based on : tow pins 2 X BP, winches 2.2 X BP, tow hook 2.5 X BP with Von mises stress <= 0.91Y	Tow hook, winch and foundations. Von mises stress <= 0.85 Y. Hook & foundation must withstand: 0 to 90 deg horizontal and 0 to 60 deg vertical (PL < 500 kN), same as above but only to 45 deg above horizontal for PL > 500 kN. Tow Hooks withstand PL and foundation Fmin.	Hook or equivalent strength 50% in excess of towline breaking strength. Design load of foundations >= breaking strength of towline system (weakest link is line) but also >= breaking strength of tow hook or brake holding load of winch (or equivalent). Von mises stress <= 0.91Y.	Design Load for winch & foundation also to be > 1.25 X winch brake load Von Mises <= 0.85Sy
Towing/Anchor Handling Equipment	Towing equipment/structure design limits - Escort Operation	Escort (additional): Structures to withstand line breaking strength horizontally and to 90 deg off vessel CL with same stresses as above.					
Towing/Anchor Handling Equipment	Tow hook				Hook to function for foreseeable line directions and have quick release operable locally (<150 N) and from bridge (<250 N). If slip is pneumatic or hydraulic, mechanical release must also be provided.		
Towing/Anchor Handling Equipment	Winches - Towing operation	Quickrelease of line (with QR notation) from wheelhouse at any angle of heel or trim. Powered winch.	Towing: Towing equip on CL and to minimize heeling. Winch quick release from bridge regardless of trim and heel and with <150N force Remote control winch slip required. Line not to be fixed to drum.	Towing: Towhook release from bridge under any heel and towline direction. Winch release locally and from bridge. Brake engageable after release and both can be done in blackout. Line attached to winch with weak link.	Towing: For winch, line to be constrained to feed onto drum in controlled manner and allow effective spooling. Weak link to drum. Ocean towages: spare line required and tension meter recommended. If winch powered by shaft alternator from main engine, alternate generator to be provided. For multi-drum, drums to be independent. Power drum brakes also to have manual control. Quick drum release from control stations even in blackout. Holding power (brake) rated at 80% of Fmin. Winch to withstand holding capacity. Foundation to withstand Fmin.	Towing: Reliable slip arrangements to release line under towline angle. Release from bridge recommended.	Tow Hook Release from Wheelhouse & Locally Towing Winch to have emergency quick release from bridge and locally Towline attached to winch with weak link Guidance: tension monitoring spooling device means to stop line jumping drum ends secondary source of winch power independent drives of multi-drum winches emergency payout speed to be controlled and suitable for application crew trained for emergency payout after emergency release, winch to be immediately ready to operate but motor not to be automatically engaged
Towing/Anchor Handling Equipment	Winches - Escort operation		Additional Escort: Towing winch to reduce tension when tension exceeds 50% of towline breaking strength and escorting not to be done on brake.	Additional Escort: Towing winch to reduce tension when tension exceeds 50% of towline breaking strength and escorting not to be done on brake.	Escort: No escort on winch brake. Load damping in winch to limit dynamic loads. To pay out if tension >50% Fmin. To spool slack rope.	Escort: Towline breaking strength >= 2.5 X maximum line tension. Load monitoring. Overload prevention to pay out at max design tension & alarm.	Escort Operations: - load monitoring on towline - over load prevention to pay out at 50% of design load

The winches on the SERVS tugs, as reviewed in Part 1 of this report, have the characteristics enumerated in Table 3.2 below, in comparison to the above Class minima.

Table 3.2 SERVS Tugs Towing Systems – Comparison to Class Minimums

SERVS Tugs Towing Systems - Comparison to Class Minimums

Description	ETT	PRT	Class Minimums		Notes	
			ETT	PRT		
Bollard Pull	tonnes	95.2	138.3		Satisfies Most Stringent Class Criteria	
Estimated Max Towline Tension:					Fails Most Stringent Class Criteria	
direct mode	tonnes	95.2	138.3			
indirect mode	tonnes	133.28	n/a		Estimated based on typical VWT performance	
Reference Load: ABS	tonnes			176.12	255.9	
BV	tonnes			142.8	207.5	
DNV	tonnes			190.4	276.6	use DNV as "Industry Standard"
Towline Breaking Strength						
ABS	tonnes			190.4	276.6	
BV	tonnes			190.4	276.6	
DNV	tonnes			293.2	304.3	use DNV as "Industry Standard"
Escort/Hawser Winch						
Make		Markey	Markey			
Model		DYSDS-62	DYS-52/WYW-20			
Render capacity		slack line only 25000 lbs. @	limited	full load render and recover	full load render and recover	
Recovering capacity		125 fpm	limited			
Dynamic Brake		none	none	dynamic brake	dynamic brake	
Towing Winch		n/a	Markey			
brake			TDS-40 mechanical/pneumatic			
Escort Hawser/Towline						
Make		Samson	Amsteel Blue			
Model		Neutron 8	800' x 10" circ +			
Size		11" circ.	100" Amsteel Blue Pennant			
Breaking Strength	tonnes	537.4	410.9	1.83	1.35	ratio to most stringent Class minimum
Aft Towing Gear		none				
main towline:						
type			steel wire rope: 6 x 36 IWRC			
length			2500 ft			
diameter			2.5"			
Breaking Strength	tonnes		294.6		0.97	Highest rated BS of wires for the three tugs (649,700 lbs.) satisfies ABS criteria but misses DNV criteria by 3%. Lower rated SWR (646,800 lbs.) misses DNV by 3.6%.
Emergency Towing Gear:						
Grommet			250 ft Nylon			
Main line			Amsteel Blue			
Line Size			10" circ.			
Surge Chain			45 ft x 3" chain			
Min. Breaking Strength	tonnes		410.9		1.35	

From the data above it can be seen that the SERVS tugs satisfy the ABS Class requirements for escort tugs, however the trend in the escort industry worldwide is to look to the higher DNV escort criteria [13] as the "generally accepted standard". Two other Class Societies, BV and GL, have followed DNV's lead and have adopted the DNV criteria as their own with little or no alteration. Therefore measured against those more stringent criteria the SERVS vessels fail to satisfy the following requirements:

- ETT:

- Escort winch does not have the ability to reduce tension when tension exceeds 50% of towline breaking strength
- Escorting not to be done on brake

- PRT:

Although the PRT's do not do any indirect escort towing, they are still deployed in an escort mode using the small bow winch, and are then used to apply direct pull. Accordingly it seems appropriate that the bow towing system should comply with Class requirements for escort towing and the aft towing system should simply meet the requirements for ocean towing gear. The following deficiencies therefore are noted:

- Escort winch does not have the ability to reduce tension when tension exceeds 50% of towline breaking strength
- Escorting not to be done on brake
- Main aft towline (SWR) achieves only 96-97% of DNV Class requirement for breaking strength

It is important to note the differences between the ABS requirements for an Escort Class Notation and those of DNV and a few other Class Societies, in order to justify the statement that ABS do NOT at present represent the highest standards for escort tugs in the industry. The critical differences are as follows:

- Stability Requirements: ABS require only that maximum applied forces do not immerse the deck edge of a tug. DNV et al have criteria that define the required ratio of righting moment to heeling moment and which therefore includes some margin of freeboard
- Winch Specifications: ABS has no requirement for winches to carry the line load on winch power, and only requires an "abort" mechanism. DNV et al require that the maximum towline force be carried on winch power only and be able to be rendered and recovered during the escort operation

On these two factors alone a vessel with an Escort Tug notation from ABS could be substantially less effective and less safe than one classed similarly by DNV, GL or BV.

3.2 Recent Industry Research

3.2.1 SAFETUG

The SAFETUG Joint Industry Project (JIP) [14] is the most significant individual piece of tug-related research ever conducted. It benefitted from the collective input of tug operators, tug Owners, designers, major equipment suppliers and the hydrodynamic researchers all acting cooperatively to ensure and enhance the safety of the emerging business of offshore escort and terminal support tugs working in exposed conditions.

In the context of towing gear, the following work was completed:

- Creation of dynamic modelling software to simulate the behaviour of a winch system in compliance with the most stringent class requirements, and to enable a tug to maintain a constant force on an attended ship in the range of sea-states expected in typical offshore terminal conditions (generally < 3 metres H_s)
- Modelling of the behaviour of the range of typical hawsers used in escort towing, to work in concert with the winches described above

This work was largely done by two major winch manufacturers who participated in the JIP: Markey Machinery performed the modelling for electric-driven winches, and IMC (Holland) did the modelling for hydraulic driven winches.

The outcome of this research was to prove that with a well-designed winch which could respond almost instantaneously to changes in tension, a tug could exert a continuous steering or braking force on an attended ship in sea-states up to at least 2.5 metres H_s and reasonably effectively in up to 3 m H_s , without risk of breaking a towline which had a breaking strain of more than 3 times Bollard Pull rating.

3.2.2 Winch Manufacturers

The only evident research in this field which has been published recently is the following:

- Markey Machinery: papers published on the development of their *Render-Recover*© winches and associated control system [15], [16], and [17]
- Ridderinkhof: paper published on the development of their *Wave Winch*© design [18]
- IMC/Kraaijeveld: paper published on the development of their *Safe Winch*© design [19]
- Jon Rie Manufacturing: published paper on research and testing of their "Auto-Position" escort winch concept [10]

The most critical elements of the research performed by the above has been integrated into the SAFETUG studies and the winch performance modelling inherent in the BERTHSIM program which evolved from that JIP work.

3.2.3 Rope Manufacturers

There has similarly been a significant body of work published on the developments in HMPE ropes for escort duty. The most significant work however has been performed by Samson Ropes, and much of that work involves detailed field testing of ropes in service to establish the life expectancy of these high-performance fibre ropes. Notably much of that research has been done on the SERVS vessels themselves.

Research has also been done on various new fibre types and on the best configuration of splices and connections, much of which was discussed in depth in Part 2 of this report. The more salient papers on this research are identified in References [20] through [23] inclusive.

3.3 Best Available Technology – Current Status

3.3.1 Industry Status

Defining the "Best Available Technology" (BAT) for any escort towing application is not easy, and certainly there is no "Universal" BAT. It must be stated categorically therefore that the BAT for each specific application may and likely will vary according to the local conditions. For example, the type of rope to be used in hot tropical conditions will likely be quite different from one used in northern regions such as Alaska.

The above provisos notwithstanding, the following are generally agreed amongst the industry to represent the best available proven towing system technology today:

- Winches: the vast majority of operators agree that the electric-driven Markey *Render-Recover*® winch is the best winch technology on the market today. There is also a general perception that Markey winches are significantly more expensive than others on the market, however when one compares winches from various qualified sources according to a common detailed specification, then Markey proves to be extremely competitive on a world-scale. This was recently proven clearly on an extensive market study done by Robert Allan Ltd evaluating components for a multi-tug contract for Australia. The Ridderinkhof "Wave Winch", the Kraaijeveld "Safe Winch", and the New Zealand-built ShipCo winches were all a close second in terms of quality and capability and each have their own followings in the industry. One cannot say therefore that there is only one supplier that can provide a technically sound and viable escort winch solution. The above group would therefore in our estimation constitute a family of suppliers who have the ability to provide high-quality electric escort towing winches. If one expands the scope to include hydraulic winches, then the Norwegian firm of Karmøy should be added to the top quality supplier list with proven experience and capability. Escort-rated winches should also be fitted with a spooling gear or similar device which applies the towline to the drum in a manner to prevent it diving under tension

- Towlines: there is little question that an HMPE rope is the product of choice in the escort towing industry. There is however a fairly wide array of rope manufacturers and rope types from which to choose, depending upon the application and the specific characteristics sought. Based on their extensive recent research performed in this area, Samson Ropes emerges as the supplier that appears to be most committed to advancing the state of the art, although there are many suppliers providing comparable products based on either the Spectra or Dyneema fibre. HMPE line strengths are all very comparable size for size, but comparison must be reviewed carefully to ensure similar test conditions

3.3.2 ADEC Assessment Criteria

Under the terms of reference of this study the available alternative technologies are to be identified under 18 AAC 75.425(e) (4)(A) of the Alaska Department of Environmental Conservation (ADEC), and to be evaluated using specific criteria, if applicable. Table 3.3 below summarizes the alternative technologies available for both tug types and describes how those potential changes may impact the vessel performance.

Table 3.3 ADEC TECHNOLOGY COMPLIANCE MATRIX

<i>Evaluation Criteria</i>	<i>Criteria Description</i>	<i>ETT Class Tugs</i>	<i>PRT Class Tugs</i>
A	<i>Whether each technology is the best in use in other similar situations and is available for use by the applicant.</i>	<p>Escort Hawser Winch: Winches with higher performance as used in other jurisdictions are readily available from a number of capable suppliers. Spooling gear would reduce the potential for line damage.</p> <p>Ropes: The ropes currently in use are, or are equivalent to, BAT</p>	<p>Forward Escort Winch: Winches with higher performance as used in other jurisdictions are readily available from a number of capable suppliers. Spooling gear would reduce the potential for line damage.</p> <p>Aft Towing Winch: the towing winch is of a high standard and satisfies all operational criteria.</p> <p>Ropes: The lines currently in use are, or are equivalent to, BAT.</p>
B	<i>Whether each technology is transferable to the applicant's operations.</i>	<p>Winch: a higher performance winch could be fitted to the ETT tugs. That would require extensive changes to the power generation system aboard the tug, plus likely some structural support changes</p>	<p>Winch: a higher performance winch could be fitted to the PRT tugs. That would require extensive changes to the power generation system aboard the tug, plus likely some structural support changes</p>

Evaluation Criteria	Criteria Description	ETT Class Tugs	PRT Class Tugs
C	<i>Whether there is a reasonable expectation each technology will provide increased spill prevention or other environmental benefits.</i>	The few recorded incidents on these vessels indicate that towlines biting into the wraps have been a cause of line failures, as has working in heavy weather. Although the incidents are very few, better winches with advanced spooling systems would definitely improve overall performance. A minor secondary benefit would be that using electrical winches there is less chance of a hydraulic oil spill on deck	The few recorded incidents on these vessels indicate that towlines biting into the wraps have been a cause of line failures, as has working in heavy weather. Although the incidents are very few, better winches with advanced spooling systems would definitely improve overall performance. A minor secondary benefit would be that using electrical winches there is less chance of a hydraulic oil spill on deck
D	<i>The cost to the applicant of achieving best available technology, including consideration of that cost relative to the remaining years of service of the technology in use by the applicant.</i>	To replace the entire winch on an ETT would cost at least about \$1.5-\$2 million per vessel, including the impact of changing generators etc. The winch onboard the tugs at present can be expected to remain fully functional for the remaining functional life of the SERVS tugs (say 15-20 years at least)	To replace the entire winch on a PRT would cost at least about \$1.5-\$2 million per vessel, including the impact of changing generators etc. The winch onboard the tugs at present can be expected to remain fully functional for the remaining functional life of the SERVS tugs (say 15-20 years at least)
E	<i>The age and condition of the technology in use by the applicant.</i>	The existing winches are 14 years old and in a very well-maintained condition. The ropes are replaced at regular intervals under a detailed inspection and testing program.	The existing winches are about 12 years old and in a very well-maintained condition. The ropes are replaced at regular intervals under a detailed inspection and testing program

<i>Evaluation Criteria</i>	<i>Criteria Description</i>	<i>ETT Class Tugs</i>	<i>PRT Class Tugs</i>
F	<i>Whether each technology is compatible with existing operations and technologies in use by the applicant.</i>	The existing winch/rope system is compatible with the capabilities of the tugs and the operational processes, but could be improved.	The existing winch/rope system is compatible with the capabilities of the tugs and the operational processes, but could be improved. Should the escort capabilities of these tugs be enhanced in any way in the future, say for instance changes to enable some indirect towing to be performed, then the existing winches would need to be replaced.
G	<i>The practical feasibility of each technology in terms of engineering and other operational aspects.</i>	It is certainly feasible to consider replacing the winch. That would involve taking the vessel out of service for at least 4-6 weeks however.	It is certainly feasible to consider replacing the winch. That would involve taking the vessel out of service for at least 4-6 weeks however.
H	<i>Whether other environmental impacts of each technology, such as air, land, water pollution, and energy requirements, offset any anticipated environmental benefits.</i>	There are no negative environmental impacts of the alternate winch technology.	There are no negative environmental impacts of the alternate winch technology.

3.4 Gap Analysis: Present Towing Systems vs. BAT

Based on the data collected it can be stated with a high degree of confidence that the current escort towing systems on the SERVS tugboats have fallen behind the ever-improving industry standard which has evolved in the past decade or so. The following are the noted gaps or deficiencies in the fitted escort towing gear systems compared to what is presently embodied in the regulations or is typically in use in other comparable jurisdictions:

3.4.1 ETT Escort Tugs

These primary escort tugs were certainly state of the art at the time of their construction in 1998. The industry has however evolved dramatically in the ensuing 14 years. The towing systems aboard the ETT tugs compare to the BAT today as follows:

- a. The escort winch does not comply with the majority of Class regulated and widely accepted requirements to have the capacity to pay out line at full load and to also recover line under significant load. Accordingly all escorting work is presently done on the mechanical brake on this winch, which is generally not considered good or safe practise. The SERVS system and the trained crews have however evolved to work very well with this equipment.
- b. The winches do not have a level wind system which could prevent line damage.
- c. The towlines in use aboard the ETT are state of the art, and are inspected to a high standard comparable to the best in the industry.

3.4.2 PRT Escort Tugs

The PRT Class tugs are a bit of an anomaly; they are very powerful tugs but are not set up for indirect towing due to their hull shape (lacking any skeg) and high towing point. Due to this limitation these vessels should NOT be used in the indirect mode, and the indications given during this study appear to reflect that fact. The PRT tugs do however act as active escort tugs and do escort towing over the bow, but not in an indirect mode. Accordingly it is appropriate that they be subject to the same standards as any other escort tug, and hence the comparison of the PRT towing gear to BAT is as follows:

- a. The escort winch does not comply with the majority of Class regulated and widely accepted requirements to have the capacity to pay out line at full load and to also recover line under significant load. As configured the winch pays out (renders) only under relatively light load conditions, and thus the brake is likely used in more severe conditions.
- b. The winches do not have a level wind system which could prevent line damage.
- c. The aft towing winch is appropriate for the type of emergency towing for which it is intended.
- d. The forward escort towing hawser is state of the art, and is inspected to a high standard.
- e. The aft towing line system is essentially two distinct parts:
 - i. The main towline (SWR)—this system is sufficient when compared to ABS requirements, but about 3–4% deficient when compared to the breaking strength standards of other major Class Society requirements.
 - ii. The Emergency Towing Package, which is a set of synthetic lines plus chain, satisfies the towing requirements of all Class Societies.

3.5 Summary

The SERVS tugs are well-equipped vessels. The towing systems however fail to reach today's BAT definition primarily in the type of escort winches used, as that technology has changed dramatically in the past decade. Additionally, the main towing wire on the PRT tugs falls short of the most stringent DNV criteria for towing service, but does satisfy the ABS Class criteria. Note the earlier comments (Section 3.1) concerning how ABS criteria do not compare well to others for escort rating.

PART 4.0 SUMMARY

4.1 Potential Equipment Upgrades

In Part 3 of this report, the following were identified as the shortcomings of the deck equipment on the SERVS tug from compliance with the generally accepted BAT for escort tugs today:

- a. The main escort winch on the ETT tugs is not a render-recover type winch, and the full towing load is presently carried on the drum brake, contrary to most Class requirements for escort towing operations.
- b. The forward winch on the PRT Class tugs is a limited render-recover type winch, and the full towing load must be carried on the mechanical brake, contrary to Class requirements for escort towing operations.
- c. Neither escort winch has a spooling gear system which would reduce line jamming and line damage
- d. The main towline (SWR portion) on the PRT tugs does not meet the strength requirements of DNV and many other Class societies, but does satisfy the requirements of ABS for towing service.

With the exception of the wire rope deficiency on the PRT tugs, the towline systems in use on both vessels certainly could be considered as BAT. The only potential upgrades to these vessels which could be considered therefore would be to alter or replace the two escort winches. Note that this does not affect the main (aft) towing winch on the PRT Class tugs. It is fair to assume that it is not practical to rebuild the existing winches, and that it would be more cost-effective and far less disruptive to the overall escort service in Prince William Sound to simply replace the winches with a modern equivalent. This assumption is corroborated by the Proposal from Markey Machinery to Crowley in 2000 to upgrade the winches on the PRT tugs [A1-13] in which it was stated: "*This price is based on not utilizing any parts from the existing winches, leaving them complete and ready for installation elsewhere.*" The existence of this 12 year old proposal also clearly indicates that the topic of winch upgrades on these tugs is not a new idea. Accordingly the basic specifications for a replacement winch in each case would be as described in the following sections.

4.1.1 Replacement Winch for ETT Class Tugs

- Configuration - all mounted above deck
- Drive - variable frequency electric
- Drum capacity - 1,000' of 3-7/8" diameter HMPE towline
- split drum configuration is recommended so that a spare line can be stowed for immediate deployment in event of a line failure
- Heavy duty level-wind, designed to "cross-lay" the towline
- Brake capacity (slip brake) = 3 x BP (app. 630,000 pounds) at bare drum
- Approximate performance:
 - line pull at barrel layer = 4 x BP at 0–12 ft./min. (stall rating)
= 3 x BP at 0–12 ft./min. (continuous)
= 0.35 x BP at app. 100 ft/min (continuous)
 - line pull at top layer = 10 tonnes at 0–app. 250 ft/min
= 1 tonne at 0–app. 750 fpm
- Render-recover capability at full rated line speed and line tension
- Instrumentation and controls:
 - remote (from wheelhouse) and local controls
 - mode selection: automatic render-recover; auto render only, manual
 - line tension display for all modes
 - line length paid out monitor
 - tension adjustment capacity
 - emergency abort

4.1.2 Replacement Winch for PRT Class Tugs

- Configuration - all mounted above deck
- Drive - variable frequency electric
- Drum capacity - 1,000' of 4" diameter HMPE towline
- split drum configuration is recommended so that a spare line can be stowed for immediate deployment in event of a line failure
- Heavy duty level-wind, designed to "cross-lay" the towline
- Brake capacity (slip brake) = 3 x BP (app. 9150,000 pounds) at bare drum
- Approximate performance:
 - line pull at barrel layer = 4 x BP at 0–12 ft./min. (stall rating)
= 3 x BP at 0–12 ft./min. (continuous)
= 0.35 x BP at app. 100 ft./min. (continuous)
 - line pull at top layer = 10 tonnes at 0–app. 250 ft./min.
= 1 tonne at 0–app. 750 fpm
- Render-recover capability at full rated line speed and line tension

- Instrumentation and controls:
 - remote (from wheelhouse) and local controls
 - mode selection: automatic render-recover; auto render only, manual
 - line tension display for all modes
 - line length paid out monitor
 - tension adjustment capacity
 - emergency abort

4.2 Vessel Compatibility with Upgrades

There would be merit to the potential upgrades described above only if the escort performance of the respective tugs would increase by so doing. The potential upgrades are therefore only beneficial if the system capability, efficiency or safety is enhanced in some meaningful way. Looking at the potential gains individually:

- a. Capability: As noted in the DNV report [A2-1], the tugs are presently limited by their stability characteristics with respect to their ability to generate any more steering or braking forces. Altering the winch performance or even increasing the line strength would not enable the tugs to generate greater escort forces. What could be accomplished however by having a high performance render-recover type winch on these tugs would be:
 - More sustained, predictable and precise control over attended ships
 - Lower fluctuations in the applied load
 - Reduced potential for line damage or parting with proper level-wind device
- b. Efficiency: With the aforesaid render-recover winch, tugs would affect more consistent and precise control over the attended ships, and accordingly the system efficiency in terms of time of applied load/hour would increase. This efficiency would increase more in rougher sea conditions, and not by much at all in calm conditions.
- c. Safety: The use of high-performance winches would mean greater and more accurate control over the potential overturning forces applied to the winch, and hence to the tug. The auto-rendering would enable the Master to concentrate on the escort operation and not directly on the winch operation. The render-recover capability would prolong rope life and reduce the potential for any surge-induced snatch loads which might break the towline. Fitting level wind devices to the winches would reduce the potential for line damage or line parting by biting into the wraps under tension.

All three of these improvements would undoubtedly represent some enhancement of the present operation, but unfortunately it is virtually impossible to quantify what these gains might represent in terms of system efficiency or safety. The net result would undoubtedly be a smoother and slightly safer operation, but whether that is worth the cost of a complete new winch and the other associated system upgrade costs is not known, and is exceedingly difficult if not impossible to quantify.

Perhaps the greatest improvement would be in the context of tug safety. With the winch specification defined in 4.1 above, the tug could never be subject to an excessive overturning force. At the present time, the overturning force on the ETT class tugs is limited by the brake capacity, and of course the Master's ability to intervene and release tension. On the PRT Class tugs the Master has control over line direction, (and hence heeling forces) and the winch brake has a maximum capacity of 320,000 lbs. (approx. equal to BP). The precise rendering capability of that winch is not clearly defined in the data reviewed.

However a major gap in the data is the absence of a known indirect steering force capability of the tugs. This should be quantified by the most accurate method possible. Only at that stage can the true performance capability of the tugs be defined and then the maximum winch capacity can be more accurately specified.

4.3 Conclusions

- a. ETT Class: These Voith Tractor tugs are the primary escort tugs in the SERVS system, yet they lack a winch with a render-recover capability, commensurate with their indirect steering force generating capability and the typical sea-states that can be encountered in Prince William Sound. The winches on these vessels certainly do not meet BAT. The towline systems on the ETT tugs are first class and are monitored and maintained to a very rigorous routine. The towlines do satisfy BAT.
- b. PRT Class: These ASD tugs are very powerful, but due to their conventional hull form are unable to and should not attempt to perform any indirect towing. These tugs perform escort duties, but can only operate in direct or transverse arrest towing modes. However the hawser winch should still be able to render-recover in the most taxing conditions encountered. The existing winch has a limited render-recover capability, which according to the information in Annex C is limited to the line pull rating of 16,500 pounds at up to 230 feet/minute. Accordingly there is no significant line tension adjustment capability at high line forces. The winches on the PRT vessels certainly do not meet BAT.

The forward hawser components on the PRT tugs are first class and are monitored and maintained to a very rigorous routine. These towlines do satisfy BAT. The main (aft) towline system satisfies the ABS criteria for the strength of towing gear, but does not meet the more stringent strength criteria of other Classification Societies. Accordingly that towline system does not satisfy BAT.

The potential to upgrade the winches on both these tug classes exists, but until the indirect towing forces available are defined, the precise heeling forces acting on each tug type cannot be established, nor can the specifications for any replacement winches be accurately defined.

PART 5.0 RECOMMENDATIONS

The following improvements to the towing systems on the SERVS tugs would bring them up to current BAT in escort towing system technology:

1. ETT Class Tugs:

- a. Conduct full-scale indirect towing tests, or perform in-depth CFD or similar computer analysis, in order to quantify precisely the escort towing capability of these tugs.
- b. Perform an analysis of the escort capability of the tugs in compliance with the DNV escort towing stability criteria.
- c. Based on the results of (a) and (b), develop detailed specifications for a render-recover type escort winch with spooling gear, all similar to that defined in Section 4.1.1.
- d. Install the new winches on the ETT class tugs.
- e. Maintain towline systems and towline maintenance and inspection systems similar to those presently in use.

2. PRT Class tugs:

- a. Conduct full-scale direct and transverse arrest towing tests, or perform in-depth CFD or similar computer analysis, in order to quantify precisely the escort towing capability of these tugs.
- b. Perform an analysis of the escort capability of the tugs in compliance with the DNV escort towing stability criteria.
- c. Based on the results of (a), develop detailed specifications for a render-recover type escort winch with spooling gear, all similar to that defined in Section 4.1.2.
- d. Install the new winches on the PRT class tugs.
- e. Maintain towline systems and towline maintenance and inspection systems similar to those presently in use.

for **ROBERT ALLAN LTD.**



Robert G. Allan, P. Eng.
Executive Chairman of the Board

RGA:da

Attachments:

- Annex A Reference Documents from PWSRCAC
- Annex B Towing Gear MV *Tan'erliq*: ETT Class Tug
- Annex C Towing Gear MV *Aware*: PRT Class Tug
- Annex D Photographic Review of **SERVS** Escort Tugs: Deck Machinery and Towing Systems
- Annex E References
- Annex F Escort Towing, Winch, and Rope Company Questionnaires
- Annex G Comparison of Fiber Characteristics

Annex A

Reference Documents from PWSRCAC

A1 - Vessel Data from Crowley

ABS Data

ABS Alert.pdf

American Bureau of Shipping. "ABS Certificate Alert." 1999-2000.

ABS Attentive.pdf

American Bureau of Shipping. "ABS Certificate Attentive." 1999-2000.

ABS Aware.pdf

American Bureau of Shipping. "ABS Certificate Aware." 1999-2000.

ABS Nanuq.pdf

American Bureau of Shipping. "ABS Certificate Nanuq." 1998-1999.

ABS Tan'erliq.pdf

American Bureau of Shipping. "ABS certificate Tan'erliq." 1998-1999.

[4] Alert SpecSheet.pdf

Guido Perla & Associates, Inc. "GPA Spec Sheet for M/V Alert." n.d.

[3] Nanuq SpecSheet.pdf

Guido Perla & Associates, Inc. "GPA Spec Sheet for M/V Tan'erliq." n.d.

Certificates of Inspection

800.400.050425.USCGcoiNANUQ

United States of America- Department of Homeland Security (United States Coast Guard). "Certificate of Inspection for 'NANUQ'." 2 April 2002.

800.400.050425.USCGcoiTNRLQ

United States of America-Department of Homeland Security (United States Coast Guard). "Certificate of Inspection for TAN'ERLIQ." 4 April 2001.

ETT Vessels: *Nanuq* and *Tan'erliq*

800.400.050425.USCGcoiNANAUQ: same as above

800.400.050425.USCGcoiTNRLQ: same as above

[1] ABS-ETT Bollard Pull Cert-1999

American Bureau of Shipping. "Certificate No. 536056-X." Port of Seattle, WA, 12 January 1999.

ETT Drawings (1 Jul 1997).pdf

Vessel Management Services, Inc. "Bid Documents of 153x48x20ft. Tanker Escort/ Spill Response Tug."
Prepared for: Crowley Marine Services, Inc. and Alyeska Pipeline Service Company. 1997.

ETT Tech Specs (1 Jul 1997).pdf

Vessel Management Services, Inc. "Technical Specifications of 153x48x20 ft Tanker Escort/Spill Response Tug."
Prepared for Crowley Marine Services, Inc. and Alyeska Pipeline Service Company. 1 July, 1997.

[7] ETT Tech Specs (1 Jul 1997)- Appendix A

Guido Perla & Associates, Inc. "Reference Documents for Vessel Management Services, Inc." 13 June 1997.
(Electrical Load Analysis, Weight and CG Calculations and Preliminary Stability Analysis)

[14] M.V. Nanuq; Scientific Trim & Stability Calcs (sic):

Guido Perla & Associates, Inc.: **ABS Approved 5 Feb, 1999** . *Note that this document has exactly the same GPA Drawing Number, (89397-843-03) without revision, as the same data contained within Ref [7] above, hence extreme care must be taken when seeking the most current and thus most accurate information)*

Nanuq_MMC 06-20-97_Connection Sketch.pdf

Markey Machinery Company, Inc. "MMCo. Preliminary 'Connection Sketch', D-41489." 20 June 1997.

[5] Nanuq_ABS 02-05-99_STB LTR.PDF

ABS Americas- A division of the American Bureau of Shipping. "Stability Letter." 5 February 1999.

Nanuq_MMC 02-05-98_Winch-Sill.pdf

Markey Machinery Company, Inc. "Documents: Crowley Valdez Tugs, S/N 17291-1 and 17291-2, Proposed Hawser Winch Width Change." 5 February 1998.

Nabuq_MMC 10-30-97_Winch Cap.pdf

Markey Machinery Company, Inc. "Documents: Braking Capacity-DYSDS-62 Hawser Winch for Valdez Tractor Tugs." 30 October 1997.

Nanuq_MMC D41515-R6_Hyd.Diag.pdf

Markey Machinery Company, Inc. "Preliminary Drawing: Hydraulic Diagram Crowley Tractor Tug." 1997-1998.

Nanuq_SII 971006-MMD-01501_Pwr.Ctrls.pdf

Markey Machinery Company, Inc. "Preliminary Drawing # 971006-MMD-01501: System Overview Power and Controls." 16 January 1998.

Nanuq_Tan'erliq DNV Escort Vessel Criterion.pdf

"Stability Reference Documents". 23 June 1997.

[6] Tan'erliq_ABS 05-06-99_STB LTR.PDF

ABS Americas. "Stability Letter." 6 May 1999.

PRT Vessels: Alert, Aware, & Attentive

801.404.990202.PRTdsgnDraw.pdf

Guido Perla & Associates, Inc. "Reference Drawings." 1998-2000.

99498-843-02 Inclining Test Results 140' Z-Drive Tug.pdf

Guido Perla & Associates, Inc. "Reference Documents." 2000.

[2] ABS-PRT Bollard Pull Cert-2000.pdf

American Bureau of Shipping. "Statement of Fact Survey- M.V."Aware" PID39428RC." 17 July 2000.

Alert_GPA 99498-835-05~_Tank Cap.Plan.pdf

Guido Perla & Associates, Inc. "Reference: Tank Capacity Plan." August 1999.

Alert_GPA 99498-843-03-1~_T&S Calcs.pdf

Guido Perla & Associates, Inc. "Project: 140 Ft Z-Drive Tug M/V Alert- Reference Documents." January 2000.

Alert_GPA 99498-843-03-6~_T&S Calcs.pdf

Guido Perla & Associates, Inc. "Project No. 99498- Reference Documents." 2000.

[10] Alert_GPA 99498-843-03-11 (GHS 00-01-24).pdf

Guido Perla & Associates, Inc. "Project No. 99498- Stability Documents." January 2000.

[11] Alert_GPA 99498-843-03-12 (GHS 00-02-04).pdf

Guido Perla & Associates, Inc. "VMS 140' General Purpose Tug- GPA No. 99498- Stability Documents." 2000.

[12] Alert_GPA 99498-843-03-12 (GHS 00-02-07).pdf

Guido Perla & Associates, Inc. "Project No. 99498- Stability Documents." January 2000.

[13] Alert_Markey 03-09-00 Winch Conv.pdf

Markey Machinery Company, Inc. "Reference Drawings: Winch Conversion Project/ Three (3) Crowley PRT-Class Tugs." 9 March 2000.

Alert_Markey 11-17-98 Stern Towing Winch.pdf

Markey Machinery Company, Inc. "Reference Drawings: VMS 140' x 10,000 HP ASD Tugs- Stern Towing Winch." 17 November 1998.

Alert_Markey_Modification Task List.pdf

Markey Machinery Company, Inc. "Modification Task-List." 30 May 2000.

PRT Design Specs (11 May 1998).pdf

Vessel Management Services, Inc. "Design Specifications for 140 x 42 x 20 Ft. 10,000 HP General Purpose Tug." Prepared for Crowley Marine Services, Inc. and Alyeska Pipeline Service Company. May 11, 1998.

PRT Drawings (2 Feb 1999).pdf

Guido Perla & Associates, Inc. "Reference Drawings." 1998-2000.

[9] PRT Stability Letter (19 July 2000).pdf

ABS- Americas Division. "Stability Letter." 19 July 2000.

[15] Crowley Crew Directive

#PRT04-003, 9-13-04 "PRT Bow Winch Operational Guideline"

[16] Crowley Incident Investigation Notification, August 16, 2004

[17] Crowley Presentation: Vessel Reliability Improvement and Assurance

PWSRCAC Board Meeting, May 3, 2012

ABS ESCORT Vessel Regulations

"Part 5- Chapter 13 Escort Vessels (1998)." *ABS Rules for Building and Classing Steel Vessels under 90 Meters (295 feet) in Length.* 2011. 79-92.

Tug overview.pdf

Prince William Sound Regional Citizens' Advisory Council. "SERVS Tugs in Prince William Sound- Fact Sheet." January 2007. www.pwsrcac.org.

A2 - DNV Final Report

20111221 PWSRCAC recommended activities.pdf

Det Norske Veritas AS. "Recommended scope of work for further studies." Proposal for Prince William Sound Regional Citizens' Advisory Council. n.d. (DATE?)

[1] Classification Society Tug Review for PWSRCAC.pdf

Det Norske Veritas. "Classification Society Tug Review for PWSRCAC- Contract No: 801.11.01." Report No./DNV Reg No.:/ 1392NFK-7, Rev 1. 24 October, 2011.

A3 - Towing Related Documents

651 431 070706 CPInBATAnyIs.pdf

Levesque, Joesph N. "A Legal Analysis of the Requirement of "Best Available Technology" (AS 46.04.04.030(e)) as Applied to Tug Escort Vessels in the 2007 Prince William Sound Tanker Oil Discharge Prevention and Contingency Plan." 2007.

800.107.040101.ITSCamsteel.pdf

McCorkle, Eric, et al. "Abrasion and Residual Strength of Fibre Tuglines." *The 18th International Tug & Salvage Convention*. 2004.

800.107.040101.samsontowlne.pdf

McCorkle, Eric, et al. "Fatigue and Residual Strength of Fiber Tuglines." *OCEANS*. 2003.

800.410.040211.towlinerpt.pdf

[3] Wilson, Stephen. "Incident Investigation Notification." 11 February 2004.

McCorkle, Eric. "Samson Rope Technologies Technical Report." 2004.

801 300 981028 APSCnewPRTs.pdf

Jones, Gregory T. "Proposal to Prince William Sound Regional Citizens' Advisory Council." 28 October 1998.

801.107.000310.SERVSollard.pdf

"SERVS Fleet Bollard Pull." SERVS Presentation, 2000.

801.410.040913.towInpcedres.pdf

[1] Leonard, Frosty. "PRT Tether Line Stowage VDZ04-022." 9 July 2004.

[2] Wilson, Stephen. "M/V AWARE Tether Line Parting." *Crowley Incident Investigation Notification*. 16 August 2004.

Dempke, Blaine. "Replacement Drum Program for DYS-52/WYW-20 Hawser Winch S/N." *Markey Project A0491*. 8 September 2004.

Tague, Walt. "PRT Bow Winch Operational Guideline DIR#: PRT04-003." 13 September 2004.

801.410.780725.CGtkrTugMan.pdf

Office of Marine Environment and Systems. *Preliminary Report of Exploratory Tanker-Tug Maneuvering Tests*. Washington, DC: U.S. Coast Guard, 1978.

801.410.7807.25.ShiphandEval

Captain James A. Atkinson, USCG. "Shiphandling Evaluation Project Trip Report 6." 1978.

801.410.781201.CGtkrTugFnl

Lancaster, J H, et al. "Report of Exploratory Tanker-Tug Maneuvering Tests of Tanker Arco Anchorage and Tug Sea Swift." Prepared for U.S. Department of Transportation- United States Coast Guard. December 1978.

801.410.931101.POVtugTrials.pdf

"Report No. 3.11548-3-SE." November 1993.

801.410.950615.SaveDisTank.pdf

Atkinson, Captain James A. *Report of Investigation into Alternatives Available by the Winter of 1995-96 that could Enhance the Ability to Save Disabled Tankers of Over 190,000 DWT in Valdez Narrows*. Charlottesville, VA, 15 June, 1995.

801.410.950701.ARCOtugStudy.pdf

The Glosten Associates, Inc. "Computer Simulations to Compare the Escort Performance of Four Tugs in Valdez Narrows Scenarios." Prepared for the Arco Marine, Inc. July 1995.

801.410.960410.EEPwksRepor.pdf

Prince William Sound- Escort Enhancement Project. Valdez, Alaska, 10 April 1996.

801.410.970301.RscuTugEval.pdf

Glosten Associates, Inc. "Evaluation of a Rescue Towing Tug for Prince William Sound." Prepared for BP Oil Shipping. 1997.

801.450.000223.PRTEquipment.pdf

"Prevention Response Tug- Oil Spill Response Equipment and Firefighting Capability." 2000.

A4 - Documents Bibliography

651 300 990512 ADECtkrPrts.pdf

Provant, Steve. "Letter regarding 'BAT Determination for the Prevention Response Tugs'." 12 May 1999.

801 300 981103 ADECPRTasBAT.pdf

Chapple, Tom. "Letter to Mr. Gregory T. Jones- SERVS." 3 November 1998.

801 431 061201 IssuesPolcy.pdf

Nuka Research and Planning Group, LLC. "Prince William Sound Escort and Response System: Issues and Policies." *December 2006: TASK 3*. 2006.

801 450 070131 VERP.pdf

2007 Prince William Sound Tanker Owners/Operators. *Vessel Escort & Response Plan*. Valdez, Alaska, 2007.

801.107.010414.EscortTugAn.pdf

Mitchell, Vince, et al. "Escort Tug Analysis for Oil Tankships in Prince William Sound and the Gulf of Alaska." 14 April 2001.

801.107.880601.TugSelection.pdf

Scalzo, Steve T. and Duane H. Laible. "Rational Selection of Tug Type and Power." *10th International Tug Convention*. Sydney, Australia, 1988.

801.107.930101.TugsStateArt.pdf

Sven Aarts of Wijsmuller Engineering BV. "Escort tugs- the state of the art." *Ship & Boat International* (January/February 1993): 33-36.

801.400.990201.SERVSTugInfo.pdf

SERVS (Ship Escort/ Response Vessel System) - Alyeska Pipeline Service Company. "General/Purpose Tugs." 1998.

801.404.060630.APSCtugData.pdf

SERVS. "SERVS Tug Data: Reference Documents." 2005-2006.

801.410.041230.TugEscortSty.pdf

The Glosten Associates, Inc. "Study of Tug Escorts in Puget Sound." December 2004.

801.410.910901.ARCOtugstudy.pdf

The Glosten Associates, Inc. "North Puget Sound Tanker Escort & Tug Assistance Study." Final Report- Prepared for ARCO Marine, Inc. and Foss Maritime Company. September 1991.

801.410.930513.EscTowTests.pdf

"Escort Towline Deployment Tests." 13 May 1993.

801.410.970320.TGALongBeach.pdf

The Glosten Associates, Inc. "Long Beach Full-Scale Trials." Report of Results from Long Beach Full-Scale Trials (ARCO Independence-S/R California and ARCO Alaska-Protector). 1997.

Tanker c-plan BAT.pdf

"Prince William Sound Oil Discharge Prevention and Contingency Plan." *PWS ODPCP, Rev.1* (January 2008): (4-19)-(4-25).

Annex B
Towing Gear
***MV Tan'erliq*: ETT Class Tug**

TAMER HQ

INSTRUCTION BOOK



Type DYSDS-62 Hawser Winch

S/N 17291-2

1998

For

CROWLEY MARINE SERVICES, INC.

SEATTLE, WA

Manufactured By:

MARKEY MACHINERY CO., INC.

P.O. Box 24788, Zip 98124

79 So. Horton St. Zip 98134

Seattle, Washington, USA

17291/1998

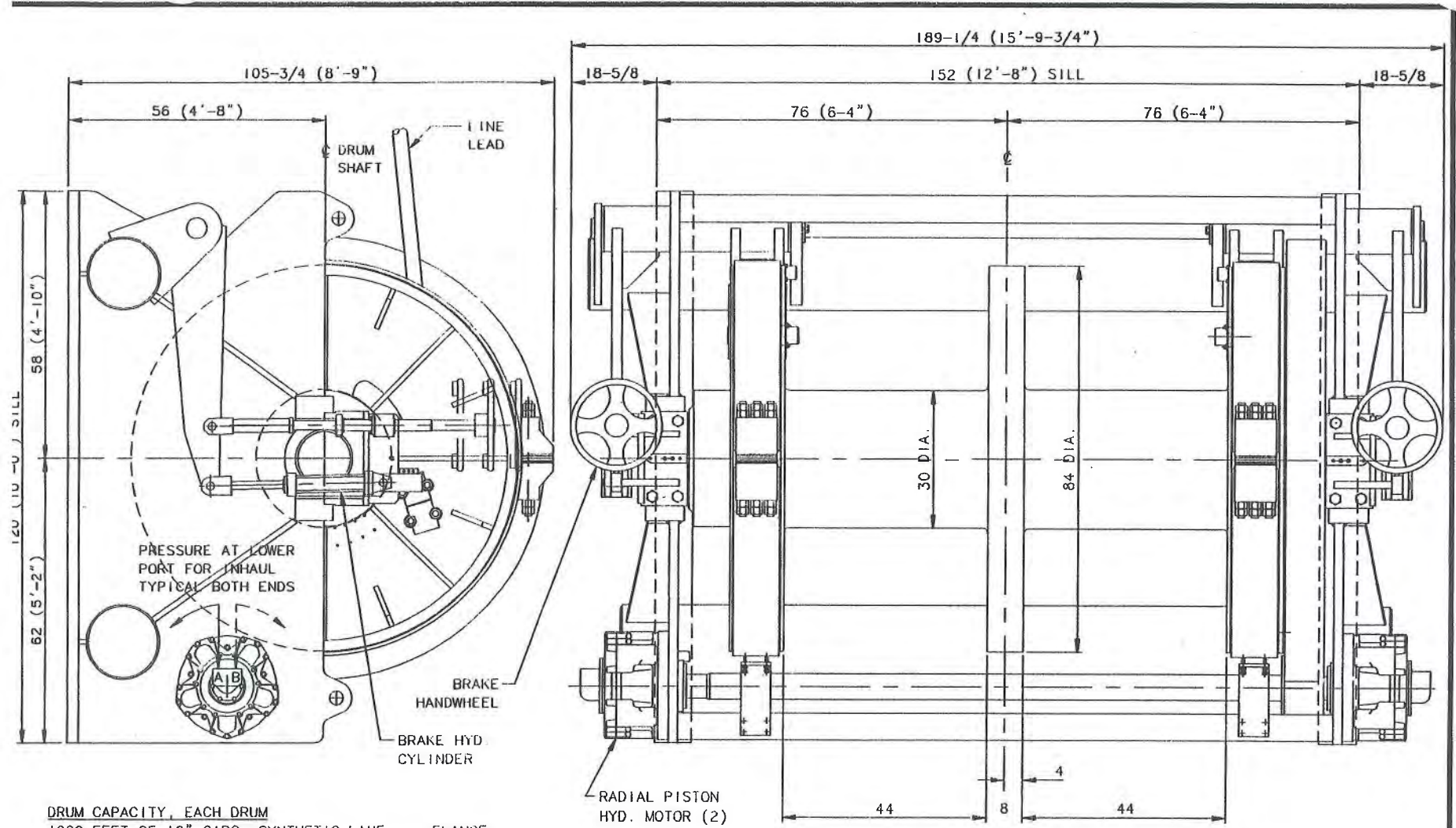

DRUM CAPACITY, EACH DRUM

1000 FEET OF 12" CIRC. SYNTHETIC LINE, w. FLANGE MARGIN TO GUIDE ONE ADDITIONAL LAYER.

PERFORMANCE, MID-DRUM

25,000 LBS LINE PULL AT APPROX. 125 FT/MIN.
12,000 LBS LINE PULL AT APPROX. 250 FT/MIN.

BRAKE CAPACITY

2 BRAKES CAPACITY, APPROX. 600,000 LINE PULL, FULL DRUM
AUTOMATIC BRAKES, HYDRAULIC SET, HYDRAULIC RELEASE
MANUAL BRAKES PROVIDE BACK-UP, AND LOCK-DOWN.
MANUAL BRAKING ADDITIVE WITH HYDRAULIC BRAKING.

HYDRAULICS/CONTROLS (TO ABS, USCG, AND IEEE-45 MARINE RULES)

FIXED DISPLACEMENT RADIAL PISTON MOTORS.
APPROX. 90 GPM AT 2600 PSI — (150 HP PUMP INPUT)
2-SPEED RANGES (ONE MOTOR/TWO MOTOR CIRCUIT)
MOTOR FREEWHEEL SERVES AS CLUTCH. LOCAL AND REMOTE CONTROL
PROPORTIONAL VALVE SPEED AND DIRECTION CONTROL
HYDRAULIC BRAKES REQUIRE 1200 PSI, PRESSURE COMPENSATED SUPPLY.

WEIGHT IS 70,000 LBS.

SEATTLE	MARKEY	WASH.
OUTLINE TYPE DYSDS-62		
DATE 03/25/98	BY R. GREENE	REV
CAD	JOB 17291	C 334911
SCALE 3/4"=1'-0"		

REV	DESCRIPTION	BY	DATE	JOB
1	CONFIRMED FINAL WEIGHT	JAA	10/09/98	17291
REVISIONS				

Chapter 1

GENERAL DESCRIPTION AND SPECIFICATIONS

1. OUTLINE

The MARKEY Type DYSDS-62 Hawser Winch is a special winch designed to suit the shiphandling requirements specified for escort and ship-assist tugs. The two-speed operation of the winch will suit either large line pull applications, or high-speed line recovery. The drum brakes are sized to accommodate line pulls up to the breaking strength of the 12" circumference synthetic line.

The Hawser Winch is provided with the following features:

- Two heavy-duty soft-line drums
- Two hydraulic radial piston motors
- Two manual/hydraulic operated drum brakes
- One set of reduction gears

For general winch arrangement, refer to MARKEY Hawser Winch Outline, Type DYSDS-62, DWG. C-33491. (See Chapter 4)

2. IDENTIFICATION

The Type DYSDS-62 Hawser Winches are identified by their serial numbers 17291-1, 17291-2. The winch data plate is located on the aft end of the port side of the base structure. The winch serial number is also welded to the base sill on the port side underneath the hydraulic motor.

3. DRUM SPECIFICATIONS

Drum Dimensions: 30" Barrel Diameter
 44" Barrel Length
 84" Flange Diameter

Rated Drum Capacity: 1000 Feet of 12" Circ. Synthetic Line in 8 layers with one additional layer as flange margin

4. WINCH PERFORMANCE SUMMARY

SLOW SPEED RANGE: 25,000 Lb. line pull at approximately 125 feet/min @ mid-working layer.

HIGH SPEED RANGE: 12,500 Lb. line pull at approximately 250 feet/min @ mid-working layer..

NOTE: Refer to the Markey Performance Chart on the next page.

5. PERFORMANCE CHART

MARKEY HAWSER WINCH for			CROWLEY MARINE SERVICES				Date	7/29/98				
MMCO Type			DYSDS-62				Drive Type	HYDRAULIC				
Barrel Diameter	30	in.	Cable Dia.	2.720	in.							
Barrel Facewidth	42	in.	Wire Circ.	12.000	in.							
Flange Diameter	84	in.										
Flange Depth	27	in.	Capacity	1,000	ft.							
Wraps	9.5											
10	82	21	203	1,423	16,677	187	8,339	374	600,220	197	1.9	MARGIN
9	76	20	190	1,219	17,867	175	8,934	350	643,048	184	1.8	MARGIN
8	71	19	176	1,030	19,240	162	9,620	325	692,458	171	1.7	
7	65	17	163	854	20,841	150	10,421	300	750,092	157	1.6	
6	60	16	149	691	22,734	137	11,367	275	818,191	144	1.4	
5	54	14	135	542	25,004	125	12,502	250	899,890	131	1.3	MID SCOPE
4	49	13	122	407	27,777	112	13,889	225	999,715	118	1.2	
3	44	11	108	285	31,243	100	15,622	200	1,124,450	105	1.0	
2	38	10	95	176	35,697	87	17,849	175	1,284,748	92	0.9	
1	33	9	81	81	41,632	75	20,816	150	1,498,350	79	0.8	
Layer #	Pitch Dia Inches	Ft/wrap	Ft/layer	Drum Cap. Feet	Linepull Lbs.	Linespeed Ft/Min.	Linepull Lbs.	Linespeed Ft/Min.	Brake Cap. Lbs.	Max. Vessel Speed, Freewheel Ft/Min.	Equiv. Vessel Speed Knots	
					Low Speed/High Pull		High Speed/Low Pull					

<p>CAUTION!!! EXCEEDING THE MAXIMUM FREEWHEEL SPEED WILL CAUSE OVERHEATING OF THE HYDRAULIC SYSTEM AND DAMAGE TO THE MOTOR.</p>
--

6. HYDRAULIC MOTOR REQUIREMENTS

90 GPM at 2,600 Psi (Refer to Markey Power/Control System Instruction Manual 17294 for information on Hydraulic components supplied by Markey.)

7. WEIGHTS

Winch, Net Weight (incl. Hydraulic Motors & Brake Cylinders): 70,000 Lbs

8. WINCH BASE

The winch base and its side frames are fabricated from steel plates and shaped to form a rigid main structure designed to withstand the large line loads associated with shiphandling duties. All shaft fits are line-bored for accuracy. The main pinion shaft is fitted with anti-friction type roller bearings, and the drum shaft has sleeve-type bushings.

9. REDUCTION GEARING

One steel cut-tooth spur gear reduction is provided to give a gear ratio of 6.17:1. The gear set is hobbled to AGMA Recommended Practices, and the beam strength of the teeth is designed to withstand all normal service loads with ample safety factor. Heavy-duty protective guards are utilized for this open-type reduction.

Gear and Pinion Description

	TEETH	DP	TOOTH FORM	FACE
Main Gear	185	2	20 deg. STUB	6"
Main Pinion	30	2	20 deg. STUB	6-1/2"
Total Gear Ratio	6.17:1			

10. DRUM BRAKE

The winch drums are each fitted with a heavy-duty T-1 steel band type brake, lined with weather-resistant non-asbestos friction lining. A hydraulic operated cylinder actuates each brake automatically when the winch is not in use. In addition, a handwheel and screw operated manual brake mechanism are provided on each brake which may be used either in place of, or with the hydraulic cylinder. A brake handbar located near the brake handwheel fits into slots on the handwheel rim and permits additional actuating

TAMERLA

INSTRUCTION BOOK



Type WYWD-20
ANCHOR WINDLASS/BOW WINCH

S/N 17292

For

CROWLEY MARINE SERVICES

SEATTLE, WA

Manufactured By:

MARKEY MACHINERY CO., INC.

P.O. Box 24788, Zip 98124

79 So. Horton St. Zip 98134

Seattle, Washington, USA

17292/1998

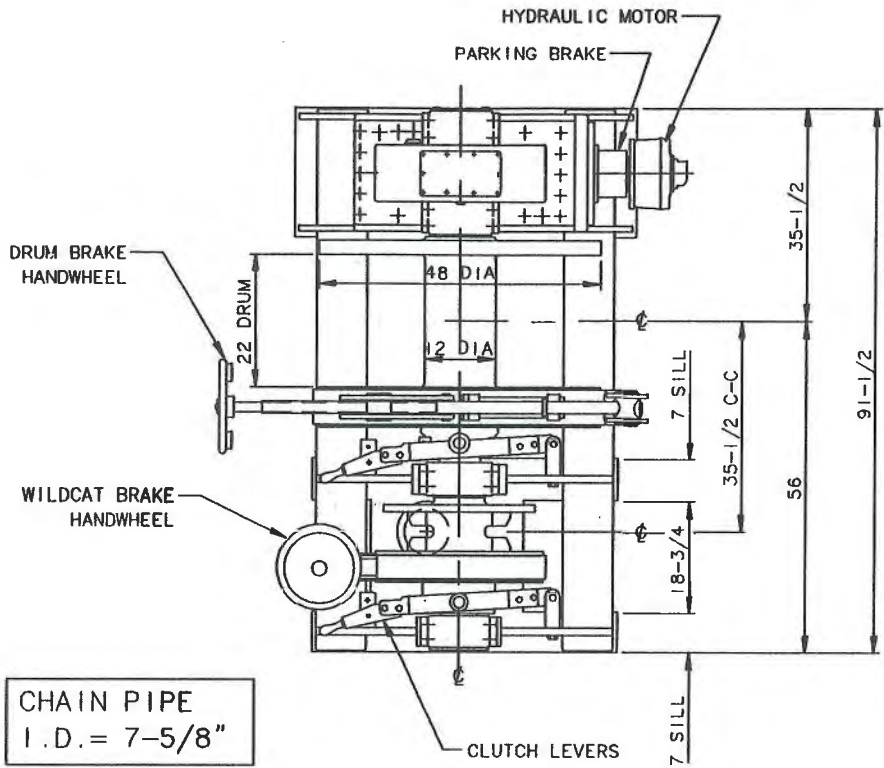

CHAIN PIPE
I.D. = 7-5/8"

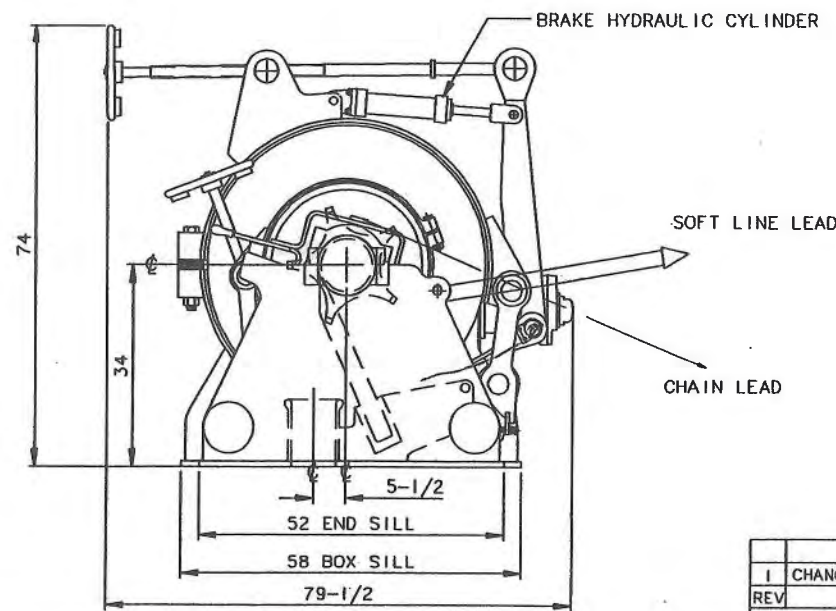

WILDCAT
ONE, TO SUIT 1-1/4" GRADE 2 S.L. CHAIN

CHAIN RATING
TO HOIST ONE 1250 LB. ANCHOR FROM 7 SHOTS (vertical) @ APPROX. 35 FT/MIN.

DRUM CAPACITY
350 FEET OF 8" CIRC. SPECTRA OR PLASMA, ON 7 LAYERS, w. MARGIN

DRUM RATING
AT 4TH LAYER OF 7, APPROX. 15,000 LB. PULL @ APPROX. 67 FT/MIN LINE SPEED.

DRUM BRAKE
HOLD APPROX. 200,000 LB. @ FULL DRUM. HYDRAULIC REMOTE OPERATED, w. MANUAL BACKUP.

HYDRAULICS
34 GPM & APPROX. 2,200 PSI RELIEF 50 H.P. PUMP DRIVE REQUIRED. PARKING BRAKE LIMITS PULL, VIA LOW RATIO BACK-DRIVING WORM SET.

APPROX. WEIGHT = 16,000 LB.

REFER TO SILL PLAN B-24541

				DATE 06-11-97		REV	
I CHANGED TO MATCH FINAL DESIGN				SRB	03/26/98	17292	BY SRB
REV	DESCRIPTION			BY	DATE	JOB	CAD
							JOB17292
REVISIONS							
						SCALE 3/4" = 1' 0"	

SEATTLE **MARKEY** WASH.

WINCH/WINDLASS
Type WYWD-20

C 33329 1

Chapter 1

GENERAL DESCRIPTION AND SPECIFICATIONS

1. OUTLINE

The MARKEY Type WYWD-20 Combination Anchor Windlass/Bow Winch is a special winch designed to suit the linehandling requirements specified for escort and ship-assist tugs. The drum is sized to accommodate 350' of 8" circumference synthetic line. The windlass is designed to suit 1-1/4" stud link chain.

The Combination Anchor Windlass/Bow Winch is provided with the following features:

- One heavy-duty soft-line drum
- One hydraulic radial piston motor
- One manual/hydraulic operated drum brake

For general winch arrangement, refer to MARKEY Combo Winch Outline, Type WYWD-20, dwg. C-33329. (See Chapter 4)

2. IDENTIFICATION

The Markey Type WYWD-20 Combination Winches are identified by their serial numbers 17292-1, 17292-2. The serial number is stamped on the winch data plate, located on the aft end of the gear case. The winch serial number is also welded to the base sill on the aft end of the gear case.

3. SPECIFICATIONS and RATINGS

Combo Winch, Net weight:	16,000 lbs
Windlass Rating:	To hoist one 1250 lb. anchor at approximately 35 FPM chain speed.
Windlass Brake Capacity:	Approx. 128,000 lb.
Chain Wildcat:	5 pocket, suitable for 1-1/4" S.L. chain
Drum Rating:	12,500 lb. line pull at approximately 57 FPM line speed, on the mid-scope layer. Refer to Markey performance Chart, page 1-2.
Drum Brake Capacity:	Approx. 200,000 lb. at full drum layer.
Drum Capacity:	350 ft. of 8" circ. soffline
Drum Dimensions:	12" Barrel Diameter 22" Face Width 48" Flange Diameter

5. BASE

The main structural member is a one piece, stress relieved weldment. The two base tubes tie the gearcase and the A-frame bearing supports together, and also provide anchoring points for the brakes and clutch linkage. The bottom surfaces are machined flat, and bearing fits are line bored for accuracy.

A heavy steel chain pipe is fitted beneath the wildcat and is provided with a rolled collar, enabling a canvas cover to be lashed over the opening to the chain locker, to exclude sea water.

6. WILDCAT

The wildcat is a five pocket design, suitable for 1-1/4" stud link chain. Construction is of fabricated steel. A sliding jaw clutch enables free payout of the anchor, or independent use of the drum. The wildcat is fitted with a manual band brake, lined with non-asbestos lining.

7. DRUM

The line handling drum is of heavy duty fabricated steel construction, for use with 8" circumference softline. A sliding jaw clutch enables free payout of the line, or independent use of the windlass. The drum is fitted with a heavy duty band brake lined with non-asbestos lining. The brake is operated by a hydraulic cylinder with a manual hand wheel as back-up.

8. REDUCTION GEARING

One steel cut-tooth spur gear reduction and one worm gear reduction are provided to give a total gear ratio of 61.5:1. The gear sets are hobbled to AGMA Recommended Practices and are designed to withstand all normal service loads with ample safety factor. The gearing is totally enclosed within a water tight gearcase.

Spur Gear and Worm Set Description:

	TEETH	DP	TOOTH FORM	FACE
Input Gear	41	4	20 deg. FULL	2-1/2"
Input Pinion	20	4	20 deg. FULL	2-3/4"
Spur Gear Ratio	2.05:1			
	TEETH	PD	PRESSURE ANGLE	FACE
Worm	2 Threads	4.695	20 deg.	8
Worm Gear	60T	25.305	20 deg.	3-1/2"
Total Reduction	61.5:1			

LINES, WIRES AND PENNANTS	
Neutron 8 Line Starboard Drum (11" X 1000' EEE)) Number:A62515-1-1	Certificate Aboard: YES
Neutron 8 Line Starboard Drum (11" X 1000' EEE) Number: A62515-1-1	Certificate Aboard: YES
for Ended	
Saturn Pennant Starboard Drum (10"X100' 9'EOE 4'EOE) Number: B50405-1-1	Certificate Aboard: YES
Amsteel Pennant Spare (10"X100' 9'EOE 4'EOE) Number: A68700-1-1	Certificate Aboard: YES
Amsteel Pennant Port Drum (10"X200' 9'EOE 4'EOE) Number: A75390-1-1	Certificate Aboard: YES
Nylon (Super Strong) Grommet Port Drum (14"X200') Number: A74225-1-1	Certificate Aboard: YES
Neutron 8 Line Port Drum (11" X 600' EEE)	Certificate Aboard: NO
Stable Braid Filler Stbd Drum (10" X 200' 6'EOE)	Certificate Aboard: YES
Amsteel Blue Bow Winch (6" X 225')	Certificate Aboard: YES
Wire Tow Bridal Leg – 1 ½"X 16' Closed Spelter Socket EE	Certificate Aboard: NO
Wire Tow Bridal Leg – 1 ½"X 16' Closed Spelter Socket EE	Certificate Aboard: NO
Amsteel Pennant Bridal Leg – 7" X 80' 6' EEE	Certificate Aboard: NO
Amsteel Pennant Bridal Leg – 7" X 80' 6' EEE	Certificate Aboard: NO
Rescue Skiff Sling (MLB4-EE-2-901X 6'5" 2PLY 1" NYLON)	Certificate Aboard: NO

INSTALL PORT DRUM: 3/15/09

SAMSON

THE STRONGEST NAME IN ROPE

CERTIFICATE OF COMPLIANCE

It is hereby certified that the products described herein have been produced in accordance with the design, performance and quality standards stated in our Quality Assurance Manual and as cited in the Catalog. In addition, it is certified that the product has been inspected and found to conform to all requirements of the customer's order or to our documentation cited herein.

This document certifies only that the product has been manufactured and inspected as described herein and no implication, certification or warranty that this product is suitable for a particular use is made.

Product Name: AMSTEEL-BLUE
Product Type: 12-Strand
Size/Length/Accessories: 10" C AMSTLBLU 200' 9'EOE 4'EOE OAL WITH 9' EYE ONE END AND 4' EYE OTHER END.
Approx. Weight (Lbs/100ft)/(Kg/100m): 240 / 357
Approx. Average Strength (Lbs)/(Kg): 1007000 / 457000
Minimum Strength (Lbs)/(Kg): 906000 / 411000
Test Method: SRT Test Method 100-02

Customer: CROWLEY MARINE SERVICES-
WEST
PO BOX 2110
JACKSONVILLE
FL
322032110

Mill Order No.: A75390

Customer Order/Contract No.: 2002260

Certificate No.: A75390-1-1

January 7, 2009



THE STRONGEST NAME IN ROPE

TAN' ME 280L

INSTALL EMOC 10W DRUM
PORT SIDE 3/15/09

CERTIFICATE OF COMPLIANCE

It is hereby certified that the products described herein have been produced in accordance with the design, performance and quality standards stated in our Quality Assurance Manual and as cited in the Catalog. In addition, it is certified that the product has been inspected and found to conform to all requirements of the customer's order or to our documentation cited herein.

This document certifies only that the product has been manufactured and inspected as described herein and no implication, certification or warranty that this product is suitable for a particular use is made.

Product Name:	SUPER STRONG		
Product Type:	Double Braid		
Size/Length/Accessories:	14"C SUPER STRONG 200' P TO P 200' PULL TO PULL GROMMET, SIEZE GROMMET EVERY 10 FT.		
Approx. Weight (Lbs/100ft)/(Kg/100m):	576 / 857		
Approx. Average Strength (Lbs)/(Kg):	646000 / 293000		
Minimum Strength (Lbs)/(Kg)	549000 / 249000		
Test Method:	SRT Test Method 100-02		
Customer:	CROWLEY MARINE SERVICES- WEST PO BOX 2110 JACKSONVILLE, FL 322032110 USA	Mill Order No.:	A74225
		Customer Order/Contract No.:	2002259
		Certificate No.:	A74225-1-1

December 4, 2008



Annex C

Towing Gear

MV Aware: PRT Class Tug



Type DYS-52/WYW-20 COMBINATION ^{✓ok}
HAWSER WINCH & ANCHOR WINDLASS

S/N 17902

yr 2000

For

Crowley Marine Services
Jacksonville, FL

Manufactured By:

MARKEY MACHINERY CO., INC.

P.O. Box 24788, Zip 98124
79 So. Horton St. Zip 98134
Seattle, Washington, USA

17902/2001

- has 800' on @ present
- + 100' pennant
- change pennant every 6 mo's
- cap^y for more (1000' max)
- hyd^c pp on aux^y.

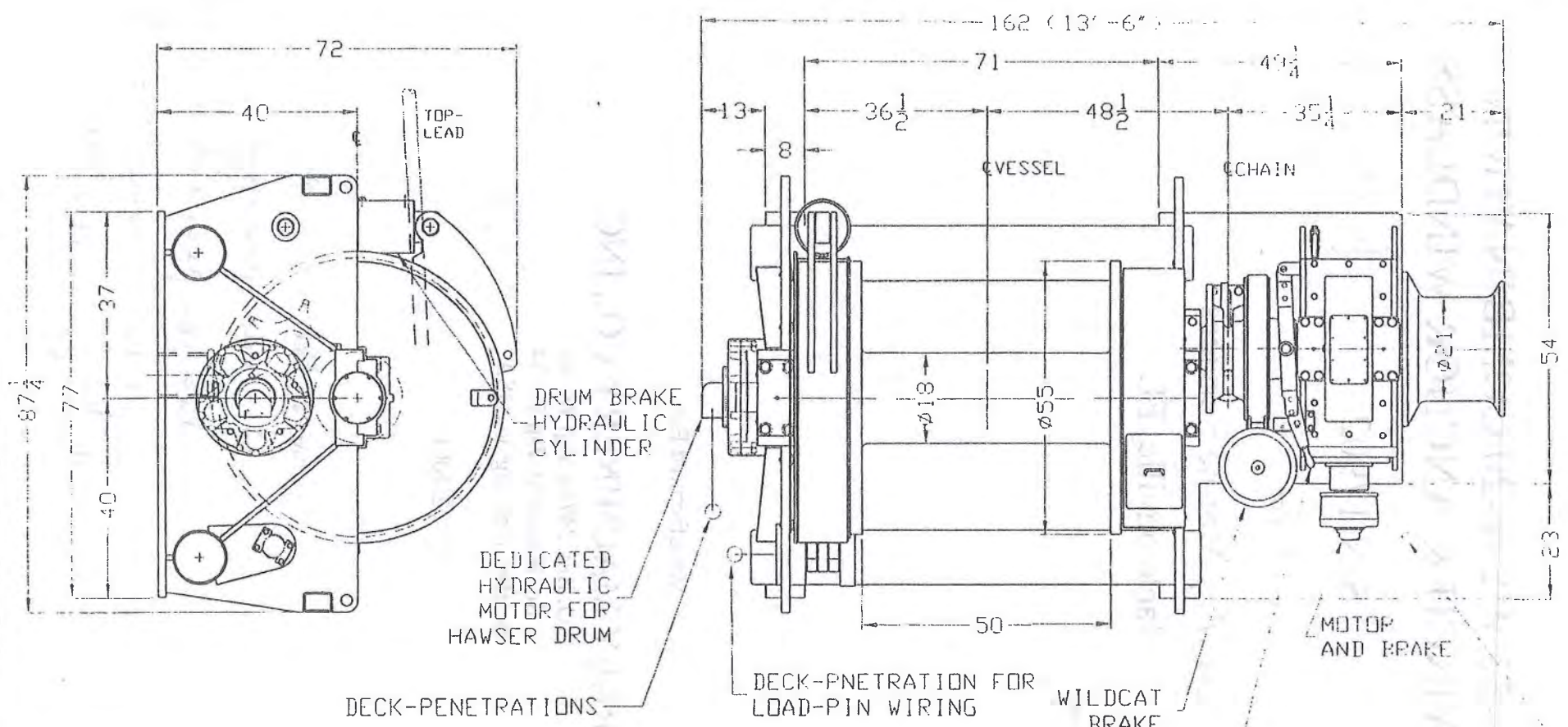

WINCH-TYPE DYS-52/WYW-20 (TWO INDEPENDENT WINCHES ON A COMMON BASE)
 HAWSER-DRUM TO STORE 700 FT. OF 10" SPECTRA
 IN SIX LAYERS, WITH MINIMAL FLANGE MARGIN
 HAWSER-DRUM RATING 16,500 LBS. LINE PULL
 AT UP TO 230 FT/MIN. LINE-SPEED, AT MID-HEIGHT
 HAWSER-DRUM BRAKE RATING WITH THE HYDRAULIC
 CYLINDER ONLY, BRAKE WILL HOLD A MINIMUM OF 320,000
 LBS. AT FULL-DRUM (480,000 LBS. AT MID-HEIGHT)
 HAWSER-DRUM HYDRAULIC REQUIREMENT TO MEET
 THE ABOVE RATING REQUIRES 100 GPM AT 2500 PSI
 HAWSER-WINCH FEATURES SYSTEM INCLUDES
 REWIND/RECOVER-MODE AND FREEWHEEL-MODE CAPABILITY
 WILDCAT FIVE-POCKET, FOR 1-1/4" S.L. CHAIN
 WILDCAT RATING TO HOIST 1250 LB. ANCHOR FROM
 7 SHOTS (VERTICAL) AT APPROXIMATELY 30 FT/MIN.
 WILDCAT HYDRAULIC REQUIREMENT TO MEET
 THE ABOVE RATING REQUIRES 40 GPM AT 2500 PSI
 WEIGHT 23,600 LBS.

CERTIFIED
 FOR INSTALLATION
 BY: S. BUNNELL
 FOR: CMS
 DATE: 10/15/00

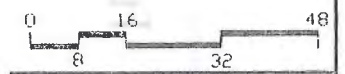

SEATTLE WASHINGTON **MARKEY** U.S.A.

COMBO HAWSER/WINDLASS
 DYS-52/WYW-20

DATE	BY	CHKD	DATE	NO.
10/15/00	S. BUNNELL		10/01/00	17902
C 33969C			REV. 1	

DO NOT SCALE DRAWING.

REV.	DESCRIPTION	BY	DATE	NO.
C	ADDED CERTIFIED NOTE	SRB	10/15/00	17902
B	TO AS BUILT DIMENSIONS	SRB	10/01/00	17902
REVISIONS				

- emergency tow pkg.

Chapter 1

GENERAL DESCRIPTION AND SPECIFICATIONS

1. OUTLINE

The MARKEY Type TDS-40 Towing Winch is a heavy-duty winch designed to suit the operating requirements encountered during towing operations.

The Towing Winch is provided with the following features:

- One heavy-duty wire rope drum
- One pendant drum
- One automatic spooling unit
- One 18" diameter warping head and rope guide
- Manual and air operated drum brake and clutch

For general winch arrangement, refer to MARKEY Outline Drawing D-41601. (See Chapter 4)

2. IDENTIFICATION

The winch data plate is located on the fwd wall of the gear box. The winch serial number, 17580, is also welded to the starboard base sill, aft of the gearbox..

3. SPECIFICATIONS & RATINGS

Net weight: 81,800 lb
 Drum capacity: 2500' of 2-1/2" wire rope
 Drum dimensions: 34" barrel diameter
 45" barrel width
 84" flange diameter
 Pendant drum dimensions: 24" x 24" x 55"

Ratings for first gear:

	Stall		90% Stall		Light Line	
	Pull (lb)	Speed (ft/min)	Pull (lb)	Speed (ft/min)	Pull (lb)	Speed (ft/min)
Full drum	155,000	0	140,000	11	55,000	105
Mid-layer	210,000	0	190,000	8	75,000	80
Barrel layer	350,000	0	315,000	5	121,000	49

Second gear operates at approximately half the pull and twice the speed of first gear.
Third gear is not recommended due to its high speed.

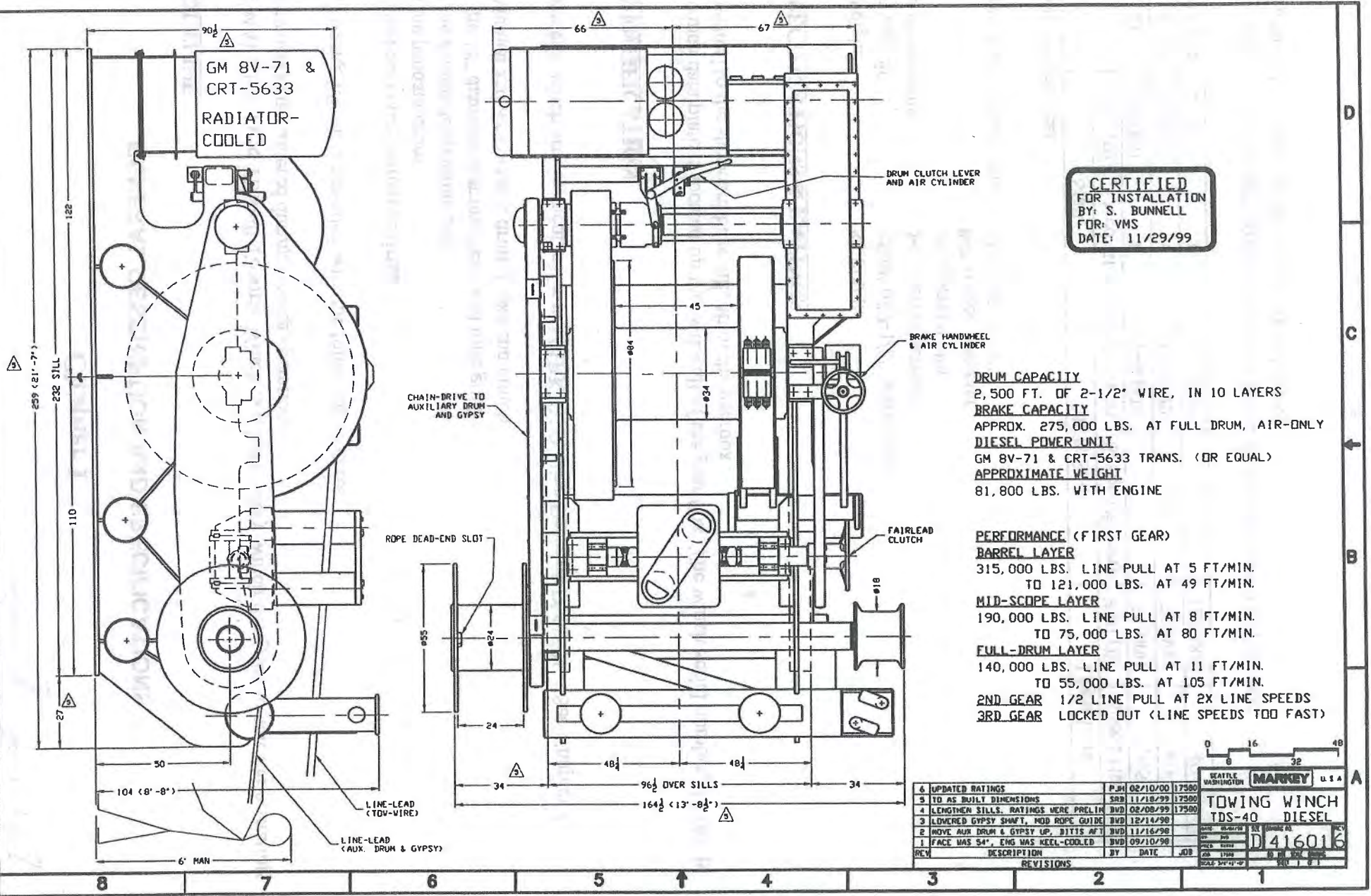

CERTIFIED
 FOR INSTALLATION
 BY: S. BUNNELL
 FOR: VMS
 DATE: 11/29/99

DRUM CAPACITY
 2,500 FT. OF 2-1/2" WIRE, IN 10 LAYERS
BRAKE CAPACITY
 APPROX. 275,000 LBS. AT FULL DRUM, AIR-ONLY
DIESEL POWER UNIT
 GM 8V-71 & CRT-5633 TRANS. (OR EQUAL)
APPROXIMATE WEIGHT
 81,800 LBS. WITH ENGINE

PERFORMANCE (FIRST GEAR)
BARREL LAYER
 315,000 LBS. LINE PULL AT 5 FT/MIN.
 TO 121,000 LBS. AT 49 FT/MIN.
MID-SCOPE LAYER
 190,000 LBS. LINE PULL AT 8 FT/MIN.
 TO 75,000 LBS. AT 80 FT/MIN.
FULL-DRUM LAYER
 140,000 LBS. LINE PULL AT 11 FT/MIN.
 TO 55,000 LBS. AT 105 FT/MIN.
2ND GEAR 1/2 LINE PULL AT 2X LINE SPEEDS
3RD GEAR LOCKED OUT (LINE SPEEDS TOO FAST)

SEATTLE WASHINGTON MARKEY U.S.A.			
TOWING WINCH TDS-40 DIESEL			
REV. 1 D 416016			
SCALE 3/4" = 1'-0"			

REV	DESCRIPTION	BY	DATE	JOB
6	UPDATED RATINGS	PJM	02/10/00	17580
5	TO AS BUILT DIMENSIONS	SRB	11/18/99	17580
4	LENGTHEN SILLS, RATINGS WERE PRELIM	BVD	02/08/99	17580
3	LENGTHENED GYPSY SHAFT, MOD ROPE GUIDE	BVD	12/14/98	
2	MOVE AUX DRUM & GYPSY UP, BITTS AFT	BVD	11/16/98	
1	FACE WAS 54", ENG WAS KEEL-COOLED	BVD	09/10/98	

D
C
B
A

4. PERFORMANCE CHART

Markey Towing Winch				Date: 2/22/00						
Winch Type: TDS-40				Customer: Vessel Management Services						
Wire Dia	2.50 in	Nominal Wraps	16.74							
Barrel Dia	34 in	Actual Wraps	17							
Barrel Width	45 in	Air Gap	5.88 %							
Flange Dia	84 in									
Pull @ barrel	121,000 lb									
Speed @ barrel	48.9 ft/min		1ST							
Stall pull @ barrel	350,000 lb		GEAR							
90% stall speed	4.9 ft/min									
Pull @ barrel	60,500 lb									
Speed @ barrel	97.8 ft/min		2ND							
Stall pull @ barrel	175,000 lb		GEAR							
90% stall speed	9.8 ft/min									
DRUM CAPACITY AND FIRST GEAR PERFORMANCE										
11	86.50	23	385	3011	147,688	132,919	12	51,058	116	212,249
10	81.50	21	363	2626	156,748	141,074	11	54,190	109	225,270
9	76.50	20	340	2263	166,993	150,294	10	57,732	102	239,993
8	71.50	19	318	1923	178,671	160,804	10	61,769	96	256,776
7	66.50	17	296	1604	192,105	172,895	9	66,414	89	276,083
6	61.50	16	274	1308	207,724	186,951	8	71,813	82	298,528
5	56.50	15	251	1035	226,106	203,496	8	78,168	76	324,947
4	51.50	13	229	783	248,058	223,252	7	85,757	69	356,495
3	46.50	12	207	554	274,731	247,258	6	94,978	62	394,828
2	41.50	11	185	347	307,831	277,048	6	106,422	56	442,398
1	36.50	10	162	162	350,000	315,000	5	121,000	49	503,000
Layer #	Pitch Dia (in)	Feet / Wrap	Feet / Layer	Line on Drum (ft)	Line Pull (lb)	Line Pull (lb)	Linespeed (ft/min)	Line Pull (lb)	Linespeed (ft/min)	Brake Capacity (lbs)
					Stall	90% Stall		Light Line		
2ND GEAR PERFORMANCE										
11	73,844	66,460	23	25,529	232	212,249				
10	78,374	70,537	22	27,095	218	225,270				
9	83,497	75,147	21	28,866	205	239,993				
8	89,336	80,402	19	30,885	192	256,776				
7	96,053	86,447	18	33,207	178	276,083				
6	103,862	93,476	17	35,907	165	298,528				
5	113,053	101,748	15	39,084	151	324,947				
4	124,029	111,626	14	42,879	138	356,495				
3	137,366	123,629	12	47,489	125	394,828				
2	153,916	138,524	11	53,211	111	442,398				
1	175,000	157,500	10	60,500	98	503,000				
Layer #	Line Pull (lb)	Line Pull (lb)	Linespeed (ft/min)	Line Pull (lb)	Linespeed (ft/min)	Brake Capacity (lbs)				
	Stall	90% Stall		Light Line						

A.S.D. TUG AWARE
EMERGENCY TOWING PACKAGE

- 1) 2500 ' X 2.5" 6 X 36 IWRC TOW WIRE:
BREAKING STRENGTH: 311 TONS, 623,029 LBS.
WEIGHT PER FOOT - 10.9 LBS. TOTAL - 13.6 TONS

- 2) 250' X 15" RP12 NYLON GROMMET:
BREAKING STRENGTH: 348 TONS, 696,000 LBS.
WEIGHT PER FOOT - 6.1 LBS TOTAL - 2436 LBS.
HEAVY DUTY SAMSON SPM LINE THIMBLE X 2
WEIGHT PER THIMBLE: 135 LBS.

- 3) 250' X 10" AMSTEEL BLUE:
BREAKING STRENGTH: 503 TONS, 1,006,950 LBS.
WEIGHT PER FOOT - 2.6 LBS. TOTAL - 520 LBS.
HEAVY DUTY SAMSON THIMBLE X 1 - 226 LBS.

- 4) 3.0" X 85 TON CONNECTING SHACKLES X 2
SAFETY FACTOR - 5
BREAKING STRENGTH: 425 TONS, 850,000 LBS.
WEIGHT PER SHACKLE: 192 LBS.

- 5) 3.0" X 45' SURGE CHAIN:
BREAKING STRENGTH: 347 TONS, 694,000 LBS.
WEIGHT PER SHOT - 8035 LBS.
WEIGHT PER LINK - 89.2 LBS.

- 6) MESSENGER LINE: 300' X 2 X 5.5" PLAITED POLY LINE.
BREAKING STRENGTH: 20.5 TONS, 41,000 LBS.
WEIGHT PER FOOT - .6 LBS. TOTAL - 173.1 LBS.

- 7) LINE THROWING GUN: .45 CALIBER
SERVICE LINES X 4
BREAKING STRENGTH: - 500 LBS.
BRASS PROJECTILES X 10

Annex D

Photographic Review of SERVS Escort Tugs: Deck Machinery and Towing Systems

Annex D

Photographic Review of SERVS Escort Tugs: Deck Machinery and Towing Systems



Figure D.1 - Vessels at Dock in Valdez, April 26, 2012

ETT *Tan'erliq* inside, PRT *Aware* outside

PRT Class Tug *Aware*



Figure D.2 - Aft Towing Gear on *Aware*:

Steel wire on the towing winch, with Emergency Towing Package (ETP) stowed in a rack above. This gear is only used for a "Rescue Tow" and would not be used for any Escort towing.



Figure D.3 - Detail of shackled connection between the steel wire on the drum and the ETP system above.



Figure D.4 - View of forward end of aft towing winch, showing the direct diesel engine drive and the wire stowage drum.



Figure D.5 - Retractable Stern Towing Pins at transom of *Aware*



Figure D.69(a) - Bow "Escort Winch" on the *Aware*



Figure D.69(b)



Figure D.7 - Detail of the forward fairlead through which the towline is led for any escort work.



Figure D.8 - Fore deck layout showing winch and staple configuration.



Figure D.9 - View looking to bow of *Aware* from forward wheelhouse console.



Figure D.10 - View looking to aft deck of *Aware* from aft wheelhouse console, over the ETP.

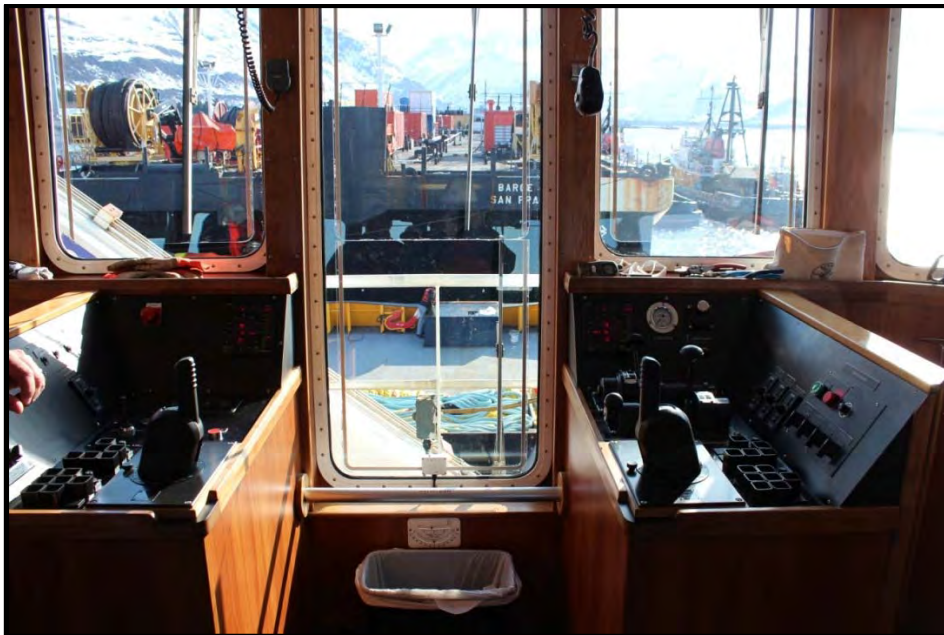

Figure D.11 - View looking aft over aft control consoles: *Aware*



Figure D.12 - Line tension monitor on forward escort winch.

ETT Class Tug *Tan'erliq*



Figure D.13 - Main escort towing winch on the "aft" working deck of *Tan'erliq*. As with all tractor tugs, escort work is done over the aft end where the skeg is located, providing the lifting forces which help to generate high indirect steering forces.



Annex E

References

ANNEX E – REFERENCES

- [1] **Assist and Escort Winches for Dynamic Seas-Final2.pdf**
Griffin, Barry. "Ship Assist and Escort Winches for Dynamic Seas- The ARR Winch for Crowley Maritime Tug RESPONSE." *International Tug & Salvage Convention- ITS 2004*. 2004.
- [2] **July00 Deck**
Griffin, Barry. "High Performance Ropes: New Strength, silent stress." *Pacific Maritime Magazine* (July 2000).
- [3] **July02 Deck**
Griffin, Barry. "Deck Machinery- Design and Quality." *July 2002* (2002).
- [4] **Oceans Conf Kobe 2004 - Paper 510**
Griffin, B.A. "High Performance Winch and Synthetic Rope Systems for Workboats, Tug Boats, and Commercial Marine Applications." (2004).
- [5] OCIMF – Guidelines on the Use of High-Modulus Synthetic Fibre Ropes as Mooring Lines on Large Tankers, 2002
- [6] OCIMF – Recommendations for Ship's Fittings for Use with Tugs, with Particular Reference to Escorting and Other High Load Operations, 2002
- [7] Perceived Advantages of Z-Drive Escort Tugs, Day 3, Paper No. 7 by C. Gale, H. Eronen, M. Hellevaara, and A. Skogman, ITS '94, Southampton UK
- [8] Mampaey DOT ShipBuilding Industry | Volume 1 | No. 2, 2007
- [9] The Carousel tug in depth; *Ship & Boat International* January/February 2007
- [10] The Auto Position Escort Winch Concept - Analytical Modeling, Trials, Tank Testing and Live Trials to Enhance Escort Tugs in Restricted Waters; Durar & Burchett, Tugology 2011
- [11] Kotug Friction-Free Towing Device; May 31, 2012:
http://www.rotortug.com/en-GB/news/38_new-azimuth-friction-free-towing-point-aftp-released-at-its.html
- [12] Improved Efficiency in Connecting Tugs to Vessels, Wardenier – Tugology 2011

- [13] DNV Towing Recommendations, Rolf Hilmar Hansen, DNV, Norway; ITS 2004, Miami (plus the actual Rule reference)
- [14] Ship Assist in Fully Exposed Conditions - Joint Industry, Project SAFETUG II Johan de Jong, Marin, The Netherlands; ITS 2010: Vancouver
- [15] Ship Assist and Escort Winches for Dynamic Seas, The ARR Winch for Crowley Maritime Tug **RESPONSE**, Barry Griffin, B.A. Griffin Associates, Inc. USA; ITS 2004
- [16] *Making it Real: from Tug Models to SMBC Monterrey*. A 25 year Case Study of the Development of Tug Winch and Connection Systems for Tankers Operating at Exposed and Offshore Oil and Gas Terminals in North America Blaine Dempke and Peter Hammerschlag, Markey Machinery Company, Inc. Barry Griffin, B.A. Griffin Associates, Inc. Tugology 2011, Antwerp
- [17] High Performance Winch and Synthetic Rope Systems for Workboats, Tug Boats, and Commercial Marine Applications, B.A. Griffin, President, B.A. Griffin Associates, Inc. Oceans Conference, 2004, Kobe Japan
- [18] Ridderinkhof Wave Winch ® High Dynamic Escort Winch Brochure
- [19] "*The Safewinch – Lifeline to Safe Towing*" SAFE Towing: BIMCO Bulletin, Volume 103 #3, 2008
- [20] Abrasion and Fibre Fatigue in High Performance, Synthetics for Ship Escort and Berthing – Terry Crump, Kris Volpenhein, and Rafael Chou, Samson, USA, ITS 2008, Singapore
- [21] Use of Tension Monitors, Data Acquisition, Technology and HPME Ropes on Omnidirectional Tugs – Joel Altus, Foss Maritime Co, USA, Greg Davis and Carolyn Westmark, Honeywell, USA, Barry Griffin, B.A. Griffin Associates, Inc., USA, Randy Longerich, Puget Sound Rope, USA, Tomas Rezanka, Measurement Technology, USA; ITS 2008, Singapore
- [22] Tug Tow Rope Systems and Planned Maintenance Procedures Robert Underhill, Jeyco Mooring and Rigging, Australia ITS 2006, Rotterdam
- [23] High Performance Ropes, Eric McCorkle, Samson Ropes, USA ITS 2004, Miami

* * *

Annex F

Escort Towing, Winch, and Rope Company Questionnaires

**ROBERT ALLAN LTD
ESCORT TOWING GEAR SURVEY**

Proj. No. 212-030
May, 2012

SURVEY - TOWING COMPANY

Question
Number

- 1 **Company Name**
- 2 **Address**
- 3 **Contact Name**
- 4 **Contact email**

*Note: The following questions relate ONLY to the use of **Tethered Escort Towing** operations which take place in confined waterways, at speeds **ABOVE 6 knots**, and where the use of indirect and transverse arrest manoeuvres are standard practise.*

- 5 **Number of Escort Tugs in Fleet**

	a	b	c	d	e	f	g	h	i	j	k	l
	<i>Vessel Type or Designer/Builder Model (if applicable)</i>	<i>Length Overall (metres)</i>	<i>Power (kW)</i>	<i>Bollard Pull (tonnes)</i>	<i>Type of Propulsion: (VSP, ASD or Z-Tractor)</i>	<i>Rated Fs-10 knots (tonnes)</i>	<i>Rated Fb - 10 knots (tonnes)</i>	<i>Year Built</i>	<i>Class Society/Notation if Applicable</i>	<i>Area/Port of Operation</i>	<i>Max. Dwt of Ship Escorted</i>	<i>If other than an Oil Tanker, identify Ship Type</i>
6 For each Tug, please identify												
(tug name)												
(tug name)												
(tug name)												
(tug name)												
(tug name)												
(add more rows as necessary)												

- 7 **For each Tug above, please identify Winch Details:**

	a	b	c	d	e	f	g	h	i	j
	<i>Maker</i>	<i>Model</i>	<i>No. of drums</i>	<i>Drum Capacity</i>	<i>Static Brake Rating</i>	<i>Dynamic (Escort) Holding Capacity</i>	<i>Does the winch have a render/recover or constant tension mechanism? (yes/No)</i>	<i>Range of loads (in tonnes) that can be carried on rendering device</i>	<i>Max. rendering speed at max load</i>	<i>Max recovery load and speed</i>
7 For each Tug above, please identify Winch Details:										
(tug name)										
(tug name)										
(tug name)										
(tug name)										
(tug name)										
(add more rows as necessary)										

- 8 **For each Tug above, please identify Towline Details:**

	a	b	c	d	e	f	g	h	i	j
	<i>Length of Towline</i>	<i>Type of Towline</i>	<i>Any Stretcher ? (Yes/No)</i>	<i>Length/Material of Stretcher</i>	<i>Any "Pennant" at outer end? (Yes/No)</i>	<i>Length/Material of Pennant</i>	<i>Type of line protector used</i>	<i>Time interval to replace towline?</i>	<i>Time Interval to rotate (end-end) towline ?</i>	<i>Any standard procedure for line condition monitoring?</i>
8 For each Tug above, please identify Towline Details:										
(tug name)										
(tug name)										
(tug name)										
(tug name)										
(tug name)										
(add more rows as necessary)										

9 Please provide any information possible concerning your success with the systems described: e.g. number of towline failures, conditions in which failures occur. Attach materials or describe below:

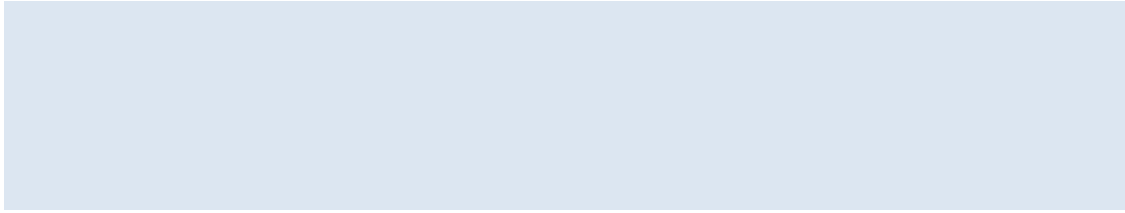

10 Regardless of the equipment fitted to your vessels at present, please advise what you consider to be the "Best Available Technology" in :

Towing Winches

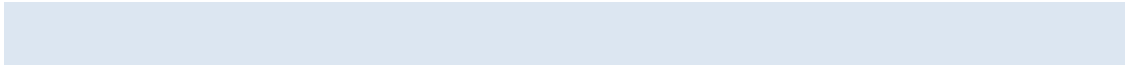

Towlines



Towline Maintenance Procedures

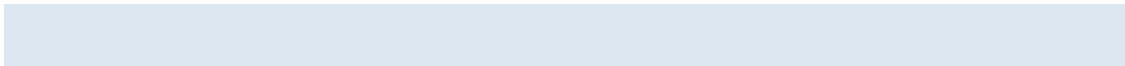

11 Tug-Tow Connection Procedures: Please provide a brief description of the standard procedures used on your tugs for connecting to the vessels to be escorted

in < 1 m Seas (Hs)



in 1-2 m Hs

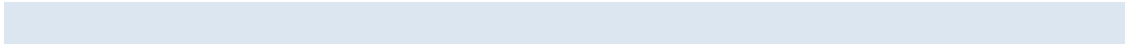

in > 2m Hs



Do you have any special fittings to facilitate tug-tow connection? Please describe/provide details.

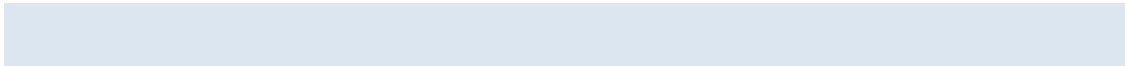

12 If you have any additional information or comments to offer re this subject, that would be appreciated!

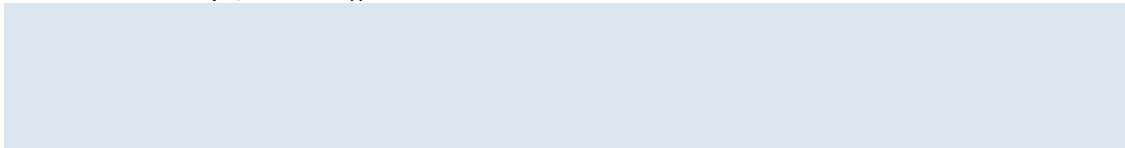

SURVEY - WINCH MANUFACTURERS

Question
 Number

1 **Company Name**

2 **Address**

3 **Contact Name**

4 **Contact email**

*Note: The following questions relate ONLY to the use of **Tethered Escort Towing** operations which take place in confined waterways, at speeds **ABOVE 6 knots**, and where the use of indirect and transverse arrest manoeuvres are standard practise.*

5 **Please Identify the MAJOR tugs (>85 tonnes BP and 34m Loa or greater) for which you have supplied Escort-Rated Deck Machinery**

	a	b	c	d	e	f	g	h	i	j
5a For each Tug, please identify	Vessel Type or Designer/Builder Model (if applicable)	Length Overall (metres)	Power (kW)	Bollard Pull (tonnes)	Type of Propulsion: (VSP, ASD or Z-Tractor)	Rated Fs-10 knots (tonnes)	Rated Fb - 10 knots (tonnes)	Year Built	Class Society/Notation if Applicable	Area/Part of Operation
(tug name)										
(tug name)										
(tug name)										
(tug name)										
(tug name)										
(tug name)										
(add more rows as necessary)										

	a	b	c	d	e	f	g	h	i	j
6 For each Tug above, please identify Winch Details:	Make	Model	No. of drums	Drum Capacity (metres x dia(mm))	Static Brake Rating	Dynamic (Escort) Holding Capacity	Does the winch have a render/recover or constant tension mechanism? (yes/No)	Range of loads (in tonnes) that can be carried on rendering device	Max. rendering speed at max load	Max recovery load and speed
(tug name)										
(tug name)										
(tug name)										
(tug name)										
(tug name)										
(tug name)										
(add more rows as necessary)										

7 **Please provide any additional information possible concerning the winch systems described above: Attach materials or describe below:**

8 **Please advise what you consider to be the "Best Available Technology" in escort winch design today: Why??**

9 **If you have any additional information to offer re this subject, that would be appreciated!**

10 **If you were to revise the typical Class rules for Deck Machinery, what would you suggest to improve operational safety of Escort Tugs ?**

SURVEY - ROPE MANUFACTURERS

Question Number

1 Company Name
 2 Address
 3 Contact Name
 4 Contact email

Note: The following questions relate ONLY to the use of Tethered Escort Towing operations which take place in confined waterways, at speeds ABOVE 6 knots, and where the use of indirect and transverse arrest manoeuvres are standard practise.

5 Please identify the MAJOR tugs (>85 tonnes BP and 34m Loa or greater) for which you have supplied Towlines for Escort Operations

	a	b	c	d	e	f	g	h	i	j
5a For each Tug, please identify	Vessel Type or Designer/Builder Model (if applicable)	Length Overall (metres)	Power (kW)	Bollard Pull (tonnes)	Type of Propulsion: (VSP, ASD or Z-Tractor)	Rated Fs-10 knots (tonnes)	Rated Fb - 10 knots (tonnes)	Year Built	Class Society/Notation if Applicable	Area/Port of Operation
(tug name)										
(tug name)										
(tug name)										
(tug name)										
(tug name)										
(tug name)										
(add more rows as necessary)										

	a	b	c	d	e	f	g	h	i	j	k
7 For each Tug above, please identify Line Details:	Make	Model	No. of drums	Length per Drum (m)	Line Diameter (mm)	Rated Breaking Strength (kN)	Elongation at Rated Load (%)	Does the winch have a render/recover or constant tension mechanism? (yes/No)	Range of loads (in tonnes) that can be carried on rendering device	Max. rendering speed at max load	Max recovery load and speed
(tug name)											
(tug name)											
(tug name)											
(tug name)											
(tug name)											
(tug name)											
(add more rows as necessary)											

8 Please provide any additional information possible concerning the rope systems described above: Attach materials or describe below:

9 Please advise what you consider to be the "Best Available Technology" in towlines for "serious" escort towing operations today: Why??

10 If you have any additional information to offer re this subject, that would be appreciated!

10 If you were to revise the typical Class rules for Deck Machinery/Towlines, and in particular the relative strength of the various components, what would you suggest to improve operational safety of Escort Tugs

Annex G

Comparison of Fiber Characteristics

**Source: Commercial Marine Product and
Technical Guide, Samson Ropes Inc.**

FIBER CHARACTERISTICS

Comparison of Fiber Characteristics

GENERIC FIBER TYPE	NYLON	POLYESTER	POLYPROPYLENE	HMPE	LCP	ARAMID	PBO
Tenacity (g/den) ¹	7.5 – 10.5	7 – 10	6.5	32 (SK-60) 40 (SK-75)	23 – 26	28	42
Elongation ²	15 – 28%	12 – 18%	18 – 22%	3.6%	3.3%	4.6%	2.5%
Coefficient of Friction ³	.12 – .15	.12 – .15	.15 – .22	.05 – .07	.12 – .15	.12 – .15	.18
Melting Point	425°– 490° F	480°– 500° F	330° F	300° F	625° F	930° F*	1200° F*
Critical Temperature ⁴	325° F	350° F	250° F	150° F	300° F	520° F	750° F
Specific Gravity	1.14	1.38	.91	.98	1.40	1.39	1.56
Creep ⁵	Negligible	Negligible	Application Dependent	Application Dependent	Negligible	Negligible	Negligible

FIBER STRENGTH RETENTION AFTER CHEMICAL IMMERSION

(HMPE strength retention after 6-months immersion)

AGENT	HMPE
Sea Water	100%
Hydraulic Fluid	100%
Kerosene	100%
Gasoline	100%
Glacial Acetic Acid	100%
1 M Hydrochloric Acid	100%
5 M Sodium Hydroxide	100%
Ammonium Hydroxide (29%)	100%
Hypophosphite Solution (5%)	100%
Perchloroethylene	100%
10% Detergent Solution	100%
Bleach	91%

* Char temperature — does not melt

- TENACITY** is the measurement of the resistance of fiber to breaking.
- ELONGATION** refers to percent of fiber elongation at break.
- COEFFICIENT OF FRICTION** is based on the rope's resistance to slipping.
- CRITICAL TEMPERATURE** is defined as the point at which degradation is caused by temperature alone.
- CREEP** is defined as a material's slow deformation that occurs while under load over a long period of time. Creep is mostly nonreversible. For some synthetic ropes, permanent elongation and creep are mistaken for the same property and used interchangeably when in fact creep is only one of the mechanisms that can cause permanent elongation.

Fiber Elongation at Break

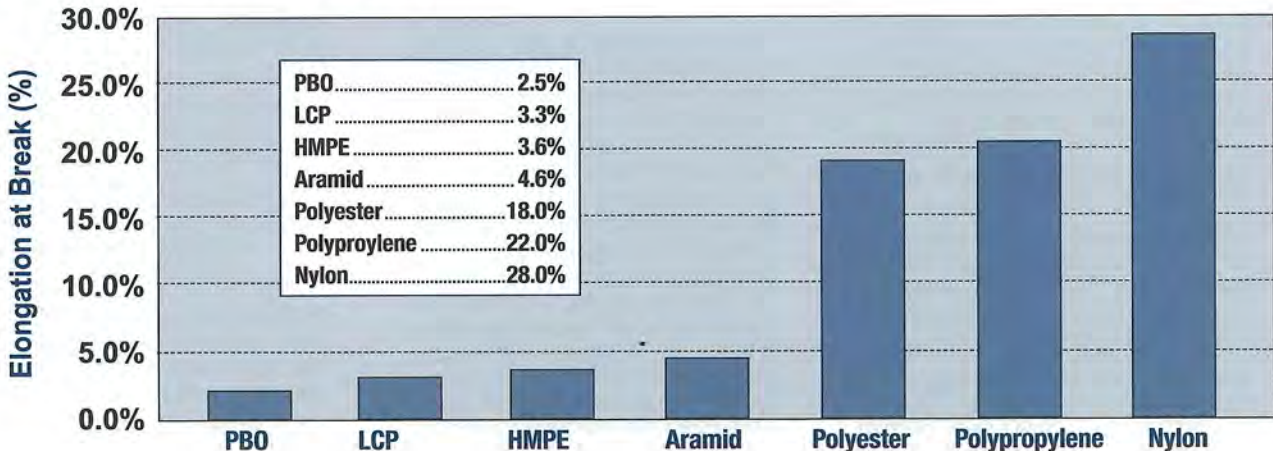

This page intentionally left blank.