

**Briefing for PWSRCAC Board of Directors – May 2020**

**ACTION ITEM**

**Sponsor:** Alan Sorum

**Project number and name or topic:** 8012 - Tanker Towline Deployment  
Best Available Technology Review

1. **Description of agenda item:** Acceptance of final report titled “Tanker Towline Deployment BAT Review” submitted by Glosten.

2. **Why is this item important to PWSRCAC:** Oil tankers operating in Prince William Sound are required to carry emergency towing equipment packages. The availability of this equipment can allow a stricken tanker to be towed safely to a place of refuge, where further action can be taken to stabilize the vessel.

A key action that must occur in the use of one of these towing systems is to successfully make the final connection between the tow package on a rescue tugboat and the vessel to be towed using a messenger line. Messenger lines can be passed to stricken vessels by hand, heaved or thrown aboard, projected by mechanical means, or picked out of the water. Weather is often a factor in vessel casualties and retrieving a line can be difficult and dangerous in adverse weather.

3. **Previous actions taken by the Board on this item:**

<u>Meeting</u>	<u>Date</u>	<u>Action</u>
Board	May 2019	Approved budget for FY2020 project.

4. **Summary of policy, issues, support or opposition:** This study evaluated the technology currently being used and available in the escort and rescue tugboat trade for messenger line deployment. A set of criteria was developed that reflect the eight criteria used by Alaska Department of Environmental Conservation (ADEC) to evaluate what constitutes the best available technology for messenger line deployment. The report presents a set of recommendations detailing use of messenger line deployment technology that represents BAT.

5. **Committee Recommendation:** The POVTS Committee recommends acceptance of this final report.

6. **Relationship to LRP and Budget:** Project 8012 is in the approved FY2020 budget and annual work plan.

**8012--Tanker Towline Deployment BAT Review – As of April 3, 2020**

**FY-2020 Budget**

Original	\$37,500.00
Modifications	\$9,369.00
Revised Budget	\$46,869.00

**Actual and Commitments**

Actual Year-to-Date	\$26,685.00
Commitments (Professional Services)	\$20,184.00
Actual + Commitments	\$46,869.00
Amount Remaining	\$0

## Tanker Towline Deployment Best Available Technology Review 4-2

7. **Action Requested of the Board of Directors:** Accept the final report titled “Tanker Towline Deployment BAT Review” submitted by Glosten, dated March 25, 2020, as meeting the terms and conditions of contract 8012.20.01 and release the report for public distribution.
8. **Alternatives:** None
9. **Attachments:** Final report titled “Tanker Towline Deployment BAT Review” submitted by Glosten.

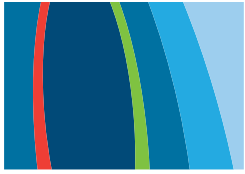

**Glostén**



PREPARED FOR

PREPARED

---

CHECKED

---

APPROVED

---

**More than  
DESIGN.**

SEATTLE, WASHINGTON  
PROVIDENCE, RHODE ISLAND  
T +1 206.624.7850 [GLOSTEN.COM](http://GLOSTEN.COM)

---

# Table of Contents

<b>Executive Summary .....</b>	<b>1</b>
<b>Section 1 Introduction.....</b>	<b>2</b>
<b>Section 2 Device Summary.....</b>	<b>4</b>
2.1 Pyrotechnic Type Devices.....	8
2.2 Pneumatic (Compressed Gas) Type Devices .....	12
2.3 Impulse-projected Type Devices.....	15
2.4 Airborne and Waterborne Drones .....	21
2.5 Surface Float Lines.....	22
<b>Section 3 Regulatory Review .....</b>	<b>25</b>
3.1 International Regulations .....	25
3.2 (US) Federal Regulations .....	25
3.3 (US) State Regulations .....	26
<b>Section 4 Literature Review.....</b>	<b>27</b>
<b>Section 5 Case Study Review.....</b>	<b>29</b>
5.1 M/V <i>Laura Maersk</i> .....	29
5.1.1 Incident Description.....	29
5.1.2 Lessons Learned.....	30
5.2 M/V <i>Ecofaith G.O.</i> .....	31
5.2.1 Incident Description.....	31
5.2.2 Lessons Learned.....	34
5.3 M/V <i>Golden Seas</i> .....	35
5.3.1 Incident Description.....	35
5.3.2 Lessons Learned.....	36
5.4 F/V <i>Emerald Sea</i> .....	37
5.4.1 Incident Description.....	37
5.4.2 Lessons Learned.....	38
5.5 M/V <i>MOL Prestige</i> .....	38
5.5.1 Incident Description.....	38
5.5.2 Lessons Learned.....	40
5.6 <i>Mobile Offshore Drilling Unit Kulluk</i> .....	41
5.6.1 Incident Description.....	41
5.6.2 Lessons Learned.....	46



<b>Section 6</b>	<b>Device Evaluation</b> .....	<b>48</b>
6.1	Methodology .....	48
6.1.1	Assumptions.....	50
6.2	Summary of Findings.....	51
<b>Section 7</b>	<b>Recommendations</b> .....	<b>55</b>
<b>Appendix A</b>	<b>Scoring Matrix</b> .....	<b>A-1</b>
<b>Appendix B</b>	<b>Device Datasheets</b> .....	<b>B-1</b>

# Revision History

Section	Rev	Description	Date	Approved
All	-	Initial issue.	3/25/20	DSD
All	A	Minor grammatical edits throughout.	4/7/20	DSD

# References

1. 18 AAC 75, *Oil and Other Hazardous Substances Pollution Control*, 27 October 2018.
2. 46 CFR, *Shipping*, 2019.
3. *Adoption of the International Life-Saving Appliance (LSA) Code*, International Maritime Organization (IMO) Maritime Safety Committee (MSC), Resolution MSC.48(66), 4 June 1996.
4. *Alaska Emergency Towing System (ETS): After-Action Report on 2012 Unalaska ETS Exercise*, Nuka Research and Planning Group, October 2012.
5. *Best Maritime Practice- Emergency Offshore Towing*, San Francisco Harbor Safety Committee, <<https://www.sfmh.org/wp-content/uploads/2017/01/Emergency-Offshore-Towing.pdf>>, accessed 12 November 2019.
6. *Container Ship Laura Maersk Adrift, Situation Report (SITREP)*, Alaska Department of Environmental Conservation Division of Spill Prevention and Response Preparedness and Response Program, SITREP No. 2, 15 July 2017.
7. “*Containership MOL Prestige adrift after fire, being towed to harbor*,” Insurance Marine News, 5 February 2018.
8. “*Fire breaks out aboard MOL containership*,” American Shipper, 5 February 2018.
9. “*Five Hurt in Engine Room Blaze*,” Sea Breezes, 19 December 2019.
10. *Gunner’s Mate Nonresident training course material*, US Navy, May 2002.
11. *IMCA Safety Flash 13/12*, International Marine Contractors Association, December 2012.
12. *Life-Saving Appliances including LSA Code, 2010 Edition*, International Maritime Organization (IMO).
13. *Mineman, Volume 7, Chapter 2: Small Arms*, United States Navy Nonresident Training Course, NAVEDTRA 14160, January 1998.
14. “*PN2 Pacific Northwest Loop 2 – “MOL Prestige” Voyage 48w – Update*,” Hapag-Lloyd, 12 February 2018.
15. *Proceedings of the Merchant Marine Council*, United States Coast Guard, Vol. 2 No. 1, January 1945.
16. *Recommendations on Equipment for the Towing of Disabled Tankers*, Oil Companies International Marine Forum (OCIMF), 1981.
17. *Request for Quotes and Qualifications, Standby Emergency Vessel Towing Services*, State of Washington Department of Ecology, 17 October 2006.
18. *Revised Recommendation on Testing of Life-Saving Appliances*, International Maritime Organization (IMO) Maritime Safety Committee (MSC), Resolution MSC.81 (70), 11 December 1998.
19. *Safety of Life at Sea (SOLAS) Consolidated Edition*, International Maritime Organization (IMO), 2018.
20. *SAR Seamanship Reference Manual*, Fisheries and Oceans Canada, Coast Guard, November 2000.

21. *Tow Bitts*, Foss, Volume 30 Issue 3, June 2017.
22. “*Tsavliris Activities for the 1<sup>st</sup> quarter 2017*,” Nafsgreen, 28 March 2017.
23. “*Update: MOL Prestige Fire Put Out, Extent of Damage Unknown*,” World Maritime News, 5 February 2018.
24. *National Transportation Safety Board Marine Accident Brief MAB1510 “Grounding of Mobile Offshore Drilling Unit Kulluk”*, Date Adopted: 5/22/2015.
25. *Kulluk Tow Incident, Situation Reports (SITREP)*, Alaska Department of Environmental Conservation Division of Spill Prevention and Response Prevention Preparedness and Response Program, Spill No. 12249936201 SITREP Nos. 1 - 13, 12/30/13 - 02/15/13.
26. *USCG Report of Marine Casualty – Emerald Sea Grounding*, 10/25/2018.
27. *Tanker Towline Deployment BAT Review, Phase 1 Interim Report*, File No. 19120.01, Rev. –, 27 December 2019.

---

# Executive Summary

This report is the culmination of a study commissioned by the Prince William Sound Regional Citizens' Advisory Council (PWSRCAC) entitled, *Tanker Towline Deployment BAT Review*. The study is an assessment and evaluation of available technologies and methods for establishing an initial messenger line connection between a disabled oceangoing vessel and a responding vessel at sea for the purposes of connecting emergency towing gear. It is emphasized that this work is not a consideration of available tools, equipment, or methods for actually towing such vessels, but rather an examination of the crucial first step of any at-sea rescue effort – the act of passing a small-diameter messenger line from one vessel to the other – and the state of the art with respect to tools and methods designed expressly for this purpose.

This report provides a summation of Phase 1 research conducted on commercially available line-throwing devices, drones, and surface float lines, brief literature and regulatory review sections, and a number of relevant case studies from recent loss-of-propulsion events occurring in the Aleutian Islands, the Gulf of Alaska, and the Canadian territorial waters off British Columbia. Lessons learned pertinent to the subject of this study are provided for each case study.

This report also provides a summary of the Phase 2 portion of this project, an evaluation conducted by Glosten to determine the best available technology (BAT) for emergency tanker towline deployment in Prince William Sound, in consideration of the unique physical/geographical and environmental characteristics of this operating environment. The report describes how Glosten determined the BAT, summarizes how different device types scored in the evaluation, and provides specific recommendations on these technologies. Information developed through this research will add to the body of work accomplished by PWSRCAC in the field of escort/rescue towing and tank vessel safety.

The BAT evaluation considered each device using eight evaluation criteria: Effectiveness, Feasibility, Transferability, Compatibility, Age and Condition, Availability, Environmental Impacts, and Cost. These criteria were weighted, and the weights were applied to each device's relative score on each criterion. All eight criteria scores were summed for each device to arrive at final scores.

The highest scoring device in the evaluation, recommended herein as BAT, is the Restech Norway PLT SOLAS pneumatic line thrower. This device fires a projectile using compressed air, meaning that it is non-incendiary, and can be reused without any replenishment costs. The PLT SOLAS has good range, meets US Coast Guard (USCG) performance requirements to obtain approval for use, and meets Safety of Life at Sea (SOLAS) requirements so that a vessel outfitted with this device need not supplement with costly additional devices to meet requirements.

The surface float lines included in this evaluation also scored highly and offer advantages in different situations from line-throwing devices. For this reason, vessels might consider carrying both the Restech Norway PLT SOLAS device *and* a surface float line system, to provide at least two options for emergency towline deployment for any given scenario.

---

## Section 1 Introduction

The job of taking a disabled vessel in tow at sea is a serious affair. Without the ability to make headway or steer, or even remain head-to-weather, a “dead ship” is truly at the mercy of the elements. In this free drift state, most vessels will orient perpendicular to the direction of the wind and lie ‘in the trough’ of (parallel to) oncoming seas. Vessel motions can become severe as sea state increases, with waves slamming underneath the flare of the bow. This is a vulnerable position for the ship; but, arguably, it presents even more risk for the responding tug tasked with taking the ship in tow.

To establish an emergency towing connection in the conventional manner, not only must the tug get close, but the master must attempt to hold position such that a towline or towing gear can practically be passed from one vessel to the other. This typically involves backing the tug toward the ship on the windward side of the bow, such that the master has an open ‘escape route’ (given that the ship will tend to drift away from the tug, rather than toward it) during the operation. However, if the tug approaches too closely it is possible for it to collide with the ship or get broached/capsized by impact from the bulbous bow. To complicate matters further, crew members must be on deck to physically make the connection, which means they are exposed to the same environmental factors acting on the ship. The master of the tug must actively consider their safety while at the same time attempting to maneuver. This is generally regarded as the most difficult and dangerous stage of any at-sea rescue operation, yet obviously critical to affecting a successful outcome. Things can, and historically do, go wrong; and in severe conditions, the task can prove impossible or exceedingly risky to even attempt.

Except in rare cases where an Orville Hook may be used to connect to a length of chain hanging in the water, the first step in such a rescue effort is to connect a relatively small diameter “messenger line” by one means or another. The messenger line is then used to facilitate passing the towing gear itself – generally either a larger diameter synthetic hawser (for relatively short-distance tows or circumstances where immediate action is required) or “hard gear” (for long-distance tows and circumstances that are less time-critical), normally consisting of stud-link chain, wire rope, and connecting shackles and/or other marine towing hardware.

It should be noted that the towing capabilities of the tug (i.e., rated horsepower/bollard pull) are almost completely irrelevant at this stage – a point that is not well understood by policymakers. Even having the most modern and sophisticated towing equipment on-hand is no guarantee of success. This delicate first act of approaching and passing a line from one vessel to the other must still be executed. It remains one of the most important and widely overlooked elements of emergency towing operations at sea. This study is the result of PWSRCAC’s recognition of this problem in their ongoing endeavor to reduce the risk of tanker operations in Prince William Sound.

The use of BAT and methods for establishing the initial messenger line connection can help to:

- Reduce the operational risks described above and increase safety for responding rescue/salvage tug crews;
- Expedite and/or simplify the process of establishing a towing connection to disabled vessels;
- Increase the range of sea states and conditions in which the operation (initial connection) can practically be conducted, and;



- Increase the overall probability of success in establishing a secure towing connection to disabled vessels.

Given that a successful rescue hinges on the ability to establish an initial messenger line connection, and considering that Prince William Sound is an ecologically sensitive environment with limited sea room, a close examination of BAT for emergency towline deployment is warranted for tank vessel operations in the region. The report sections that follow are a summary of the available technology types for emergency towline deployment, followed by a description of the analysis conducted by Glosten to objectively score the available technologies and methods against eight evaluation criteria. Scoring methodology, results, and final recommendations are presented.

---

## Section 2 Device Summary

The Glosten team began this study by conducting research on different technologies and methods commonly used by or intended for the marine salvage and towing industries (including ship escort services) for transferring a messenger line between a drifting oceangoing vessel and a responding towing vessel. Information was gathered by way of extensive web search and follow-up phone correspondence with device manufacturers, experienced responders, and distributors.

Four basic types of line-throwing devices were identified in this initial research effort:

- **Pyrotechnic type** – These devices use the combustion of a solid rocket fuel composed of compressed gunpowder or other composite propellant to propel a projectile through the air with light cordage attached.

This is the most common type of line-throwing device carried on deep draft vessels. Such devices are intended as a simple way to satisfy the SOLAS requirement that oceangoing vessels be equipped with at least one line-throwing device and not less than four projectiles capable of carrying a line at least 230 meters (in calm weather) with reasonable accuracy.

- **Pneumatic (compressed gas) type** – These devices use the rapid release of compressed air or CO<sub>2</sub> to propel a projectile through the air with light cordage attached.

These devices are typically more difficult to quickly re-fire than pyrotechnic and impulse-projected type devices, and some have relatively short ranges. But, these devices are infinitely reusable/rechargeable and are generally safer to operate than incendiary projectiles. They are common on rescue/salvage tugs and vessels requiring frequent ship to ship transfer operations (e.g., certain commercial fishing vessels).

- **Impulse-projected (granular explosive cartridge) type** – These devices use the activation of a blank granular explosive (i.e., gunpowder) cartridge in a converted or purpose-built rifle/gun to launch a projectile with light cordage attached.

Because these devices fire a relatively small and/or heavy projectile (typically either a brass rod or molded butyl rubber) at high velocity, impulse-projected type devices are reported to have great accuracy. These are commonly used for government and military applications in the United States, Canada, the United Kingdom, France, and other nation states. USCG has established standards for impulse-projected type line-throwing appliances, detailed in 46 CFR §160.031; but, interestingly, most makes/models in use do not meet the SOLAS range requirement of 230 meters. Most impulse-projected type devices are regulated as firearms and require special training and passing a background check to operate. Availability is also extremely limited for non-governmental/non-military users.

Impulse-projected type devices are standard for underway replenishment operations involving US Navy and Military Sealift Command vessels.

- **Airborne and waterborne drones** – These devices make use of remotely controlled airborne and waterborne drones capable of carrying a light line, or *floating line* in the case of waterborne drones, from a responding vessel to a stranded or disabled vessel.

These technologies are still under development, and though not commercially available for salvage or emergency towing applications specifically, future drones may offer distinct advantages in certain circumstances – particularly in cases where it may be impossible or

exceedingly dangerous to closely approach a stranded or disabled vessel. As prototypes emerge, it is expected that airborne drones may be capable of flying a line several times farther than the effective ranges of projectile-based line-throwing devices. Waterborne drones have already proven capable of delivering a larger diameter messenger line or synthetic towline directly to a stricken vessel by towing it on the surface of the water. This can save valuable time in an emergency at sea. Waterborne drones are also less affected by wind than airborne projectiles and thus may be effective in a broader range of conditions.

Likely disadvantages of airborne and waterborne drones include lack of availability, high initial cost/replacement cost, special training and licensure of drone operators, limited battery life, and limiting environmental conditions for drone operation and recovery.

In addition to drones and projectile-based line-throwing devices, the following tools and methods for transferring a messenger line were investigated:

- **Heaving line** – A heaving line is the simplest and most common method for passing a messenger between two vessels in protected waters or calm conditions, or from a vessel to a pier or dock apron (or vice versa). A heaving line is composed of a length of light line, generally 3/8-inch diameter or less, weighted at one end with a monkey's fist or other object to improve range and accuracy. The line is coiled and hurled manually toward the intended target, with slack allowed to play out freely while the weighted end is in flight. The person throwing keeps hold of the bitter end, such that a hawser or larger diameter messenger line can be attached and pulled across from one vessel to the other.

This method is quick and easy and works well for close-range applications (i.e., mooring) where it is impractical to simply pass the larger line across directly. A heaving line is *not* a suitable method of passing lines between two vessels at sea or in severe weather conditions.

- **Surface float line** – A float line is another simple method for passing a line between two vessels and may be used to advantage in a variety of conditions and circumstances. A float line is a buoyant messenger line of sufficient length to reach from the disabled vessel to the responding vessel (or vice versa) by floating on the water's surface. The distal (bitter) end is deployed into the water while the line body is allowed to stream out on the surface, either by drifting downcurrent, or by the motion of the disabled vessel as it drifts downwind. A float line can also be towed astern by the responding towing vessel and draped across the bow of the disabled vessel. In any case, a float line is intended to be retrieved from the surface by crewmembers on deck, typically with a pike pole or, preferably, a manually heaved grapple hook such as those used in commercial crab fisheries.

The primary advantages of a float line are that it can be deployed in advance of responding vessel arrival, is highly effective and safer to use in severe metocean conditions, and eliminates a step from the towline connection process because the messenger line is passed directly. Line-throwing devices, by comparison, require the passage of light line or cordage first, as the larger-diameter messenger cannot be carried by airborne projectile. However, to work effectively, a float line must be positively (not neutrally) buoyant, conspicuously colored and/or lighted, and designed to draw out in a straight line on the water's surface using a drag device or other means, such that it is retrievable at a safe distance.

Each of the previously mentioned technologies and methods has inherent advantages and disadvantages that come to be important in certain circumstances. Advantages and disadvantages of each device type are summarized in Table 1. A catalog of different devices in each of the aforementioned categories is presented in the following sections (2.1 – 2.5). Datasheets from the manufacturers of many of the devices are included in Appendix B.

**Table 1 Device type advantages and disadvantages**

<b>Device Type</b>	<b>Advantages</b>	<b>Disadvantages</b>
Pyrotechnic	<ul style="list-style-type: none"> <li>• Relatively low per-unit cost.</li> <li>• SOLAS compliant.</li> <li>• USCG compliant.</li> <li>• Excellent range.</li> <li>• The most common brands are readily available.</li> <li>• Requires no special training or certification.</li> <li>• Quick to deploy.</li> </ul>	<ul style="list-style-type: none"> <li>• Complete cost of SOLAS set (four units) and regular replacement parts is expensive.</li> <li>• Sub-optimal accuracy, susceptible to wind deflection.</li> <li>• Active combustion in the projectile (fire risk).</li> <li>• Single use/not rechargeable.</li> <li>• Fixed shelf-life.</li> <li>• Potentially dangerous to operate/can cause injury.</li> <li>• Hazardous classification makes it difficult to ship.</li> <li>• Lacks floating or illuminated components, potentially complicating retrieval.</li> </ul>
Pneumatic	<ul style="list-style-type: none"> <li>• No fixed shelf-life.</li> <li>• Fully reusable/rechargeable.</li> <li>• No hazardous or combustible materials.</li> <li>• Generally better accuracy than pyrotechnic type devices.</li> <li>• Readily available.</li> <li>• Some units have floating or illuminated components.</li> </ul>	<ul style="list-style-type: none"> <li>• Varying ranges, dependent on specific device.</li> <li>• Somewhat susceptible to wind deflection.</li> <li>• Not all models SOLAS compliant.</li> <li>• Requires special approval from USCG.</li> <li>• Potentially dangerous to operate/can cause injury.</li> <li>• Requires training and familiarization with the device.</li> </ul>

<b>Device Type</b>	<b>Advantages</b>	<b>Disadvantages</b>
Impulse-projected	<ul style="list-style-type: none"> <li>• Exceptional accuracy.</li> <li>• Resistant to wind deflection.</li> <li>• Proven effectiveness.</li> <li>• Reusable/rechargeable.</li> <li>• Most available with floating line or projectile.</li> </ul>	<ul style="list-style-type: none"> <li>• Shorter effective range.</li> <li>• Potentially dangerous to operate/can cause injury.</li> <li>• Not readily available.</li> <li>• Not SOLAS compliant.</li> <li>• Not USCG compliant, except on military vessels.</li> <li>• Regulated as a firearm by ATF.</li> <li>• Requires special training and background check for users.</li> </ul>
Airborne/waterborne drone	<ul style="list-style-type: none"> <li>• Waterborne drones may prove effective in high wind conditions.</li> <li>• Could afford effective ranges far surpassing conventional tools.</li> <li>• Could prove effective in circumstances where other types of devices are not (i.e., when it is too dangerous to approach within range).</li> </ul>	<ul style="list-style-type: none"> <li>• Technology is nascent/still under development.</li> <li>• High up-front/replacement cost.</li> <li>• Single points of failure (batteries, drone crash, failure to launch, etc.)</li> <li>• Requires special training and licensure of operators.</li> <li>• Aerial drones not usable in high-wind conditions.</li> <li>• Meets no line-throwing regulatory requirements at present.</li> </ul>
Surface float lines	<ul style="list-style-type: none"> <li>• Simple, quick to deploy, effective.</li> <li>• Usable in foul weather and low light conditions.</li> <li>• Allows tug to maintain safe distance.</li> <li>• Can save valuable time by delivering messenger line directly.</li> <li>• Readily available.</li> <li>• Can often be improvised with materials already on board.</li> </ul>	<ul style="list-style-type: none"> <li>• Requires force of movement through the water to deploy properly.</li> <li>• Does not work in all environmental conditions.</li> <li>• Introduces propeller fouling risk.</li> </ul>

The Orville Hook barge retrieval system, developed in 1970 by former Sause Bros. Port Captain, Orville “Bud” Fuller, is another tool that could potentially be used to take a disabled ship in tow in an emergency; however, it is not investigated in this report. The Orville Hook is a hook-shaped piece of heavy plate steel with a slot in the throat opening designed to capture a link of chain hanging vertically in the water column. It is used by towing it astern of a towing vessel, suspended at depth by one or more Norwegian Buoys or similar surface floats. As the towing vessel executes a turn around the free hanging chain, the Orville Hook, trailing behind, comes

into contact with the body of the chain. If the open side of the hook is facing the right direction, the throat opening will slide over an individual chain link and “catch” - held in place by the width of the adjacent chain link below it. The towing vessel may then tow ahead, with the Orville Hook acting as the connecting link between the tow wire on the tug and the chain connected to the barge or disabled vessel.



**Figure 1 Orville Hook; photo from [marysramblins.blogspot.com](http://marysramblins.blogspot.com)**

The review team excluded Orville Hooks from the scope of this study as they are not a method for passing a messenger line and there is a lack of publicly available information documenting the use of an Orville Hook for ship rescues. The Orville Hook was originally developed to take unmanned barges (not ships) in tow in the event of a tow wire failure at sea. Subject matter experts on the review team also consider the Orville Hook system to be unsuitable for use on tank vessels, particularly in water bodies with limited sea room like Prince William Sound, for four reasons:

- A lengthy section of anchor chain cannot be safely lowered or suspended in the water column if the subject vessel is without auxiliary power (band brakes on windlasses lack adequate holding power for the weight of chain and anchor).
- The Orville Hook system takes considerable time to rig and deploy in comparison to line-throwing devices and float lines.
- The Orville Hook itself, weighing over 150 pounds, cannot be safely handled/deployed on deck in severe weather.
- Multiple passes around the suspended chain are often necessary before a successful connection with an Orville Hook is made.

## 2.1 Pyrotechnic Type Devices

Pyrotechnic type devices are the most common type of line-throwing devices found on commercial vessels. They are the simplest way to satisfy the SOLAS requirements, designed to meet but not exceed the standards of the requirement. The primary advantages of these devices



include their commercial availability, ease of deployment, and great range – all systems in this category meet or exceed the SOLAS range requirement of 230 meters. However, these systems also have a relatively short shelf life, are only good for single use, generally lack firing accuracy (particularly susceptible to wind deflection), do not have any floating components, and can be dangerous. Though uncommon, injuries do occur on occasion, usually related to accidental discharge or discharge of expired units.



**Figure 2** Photo of an injured person’s shin, caused by inadvertent activation of an expired pyrotechnic type line-throwing device; photo from IMCA Safety Flash 13/12

The single-use aspect of pyrotechnic type devices means that a vessel must carry four such devices in order to satisfy the SOLAS requirement. The rocket portion of the kit expires after approximately three years and must be replaced, though most manufacturers do sell rocket replacement kits such that the canister and line portions of the kit can be reused. This means that though the cost for an individual unit is low (\$500 - \$700), the cost of a complete SOLAS-approved kit of four units and the regular component replacement costs can add up. Discount versions of these units can be located for sale online, but they can only be delivered to ports in Asia and the reliability of the companies is difficult to determine. Because of the replacement costs associated with each use of these units, it is impractical to allow the crew to practice using them during training exercises, which is a drawback compared to other device types.

Additionally, because pyrotechnic devices work by combustion of a solid rocket fuel contained within the projectile itself, it is possible, however unlikely, for pyrotechnic type devices to ignite fires on the deck of a vessel – either the receiving vessel, or vessel from which the device is activated. For this reason, alternative types of line-throwing devices are generally preferred for operations involving tank vessels or tank barges, where flammable oils and vapors may be present on deck. Pyrotechnic type line-throwing devices are also considered hazardous and subject to special requirements for transport and carriage on board marine vessels (and other transportation modes).











**Figure 3** Photo of a pyrotechnic type line-throwing device being activated from the deck of a vessel at sea; photo from survivitecgroup.com

The following table details some of the models of pyrotechnic type line-throwing devices.

**Table 2** Pyrotechnic devices, images from manufacturer websites and brochures

Make	Model	Description
<b>Pains- Wessex</b>	Linethrower 250  	<ul style="list-style-type: none"> <li>• The most commonly used, well-known product for this type of device.</li> <li>• Cost: \$700 per unit, \$250 for replacement rockets.</li> </ul>

Make	Model	Description
Ikaros	Line Thrower 	<ul style="list-style-type: none"> <li>• Can be purchased with line buoyant head, to facilitate recognition/location in the water.</li> <li>• Offers greater firing range than similar pyrotechnic type devices – 300 meters or more.</li> <li>• Cost: \$470 per unit, \$200 for replacement rockets.</li> </ul>
Comet	Linethrower 250 	<ul style="list-style-type: none"> <li>• Similar or identical to the Pains-Wessex model above.</li> <li>• Cost: \$700 per unit, \$250 for replacement rockets.</li> </ul>
Huahai Marine Signals Mfg Co, Ltd	Line Throwing Unit 	<ul style="list-style-type: none"> <li>• Limited product information available.</li> <li>• Assumed similar characteristics and price to other pyrotechnic devices.</li> </ul>
Huahai Marine Signals Mfg Co, Ltd	Line Throwing Apparatus 	<ul style="list-style-type: none"> <li>• Limited product information available.</li> <li>• For delivery to vessels at berth in Singapore only.</li> <li>• Cost: \$70 - \$90, no replacement rockets available.</li> </ul>
Qindao Good Brother Marine Life-Saving Appliance Co., LTD	Line Throwing Appliance PSQ230 	<ul style="list-style-type: none"> <li>• Limited product information available.</li> <li>• Appears similar to other pyrotechnic type devices.</li> <li>• Cost: \$210, no replacement rockets available.</li> </ul>

Make	Model	Description
SHM	Line Throwing Apparatus 	<ul style="list-style-type: none"> <li>Limited product information available.</li> <li>Assumed similar characteristics and price to other pyrotechnic devices.</li> </ul>
Sea Marine	Linethrower 250 	<ul style="list-style-type: none"> <li>Limited product information available.</li> <li>Assumed similar characteristics and price to other pyrotechnic devices.</li> </ul>
Global International	Line Throwing Apparatus 	<ul style="list-style-type: none"> <li>Limited product information available.</li> <li>Assumed similar characteristics and price to other pyrotechnic devices.</li> </ul>
Matchau	Line Throwing Unit 	<ul style="list-style-type: none"> <li>Limited product information available.</li> <li>Assumed similar characteristics and price to other pyrotechnic devices.</li> </ul>

## 2.2 Pneumatic (Compressed Gas) Type Devices

Compressed gas devices require no special license, have no shelf life, and do not contain combustible materials. Some are fired using disposable CO<sub>2</sub> cartridges, while others allow the user to reload a compressed gas cylinder/chamber from an air compressor, SCUBA cylinder, or ship's service air system.

In general, compressed gas devices have a higher up-front cost than individual pyrotechnic type devices but make sense for operations where frequent use is expected, owing to their rechargeability and unlimited shelf life. Not all compressed gas devices meet the SOLAS requirements for line range. Units that do meet the requirements prove cost effective compared



to pyrotechnic devices since most kits come with multiple projectiles so only a single, reusable kit is required.

The rechargeability of compressed gas units also allows crews to train with them for effectively no materials cost. Pyrotechnic type line-throwing devices, though still possible to activate in training exercises, are not reusable. Expended units/charges have to be replaced, constituting an expense for the vessel operator.

Compressed gas type devices are preferred for applications involving vessels carrying oil or other flammable products in bulk, as there is some degree of risk that pyrotechnic type devices, due to the nature of their propellant, can ignite flammable substances or vapors on the deck of a vessel.



**Figure 4** Photo of a pneumatic type line-throwing device (Vonin L-75) being activated from the deck of a vessel at sea; photo from [ship-technology.com](http://ship-technology.com)

Unlike pyrotechnic type devices, some compressed gas devices have been specifically designed for messenger line transfer, with proven effectiveness in practical application. SOLAS-approved versions capable of firing at least 230 meters are available, though most devices available in this category have shorter ranges. Compressed gas devices require a variance (special approval) from USCG for compliance with requirements set forth in 46 CFR, as only impulse-projected and rocket (pyrotechnic) type line-throwing devices are expressly approved. 46 CFR § 160.040-2, paragraph c) reads, “[a]lternate arrangements which meet the performance requirements of this subpart will be given special consideration.”

One potential disadvantage of compressed gas devices is that they have “mixed results” on firing accuracy. Some of the available devices offer high firing pressures, but those devices with slower projectile velocities are particularly susceptible to wind deflection in practical application.

**Table 3 Pneumatic devices, images from manufacturer websites and brochures**

Make	Model	Description
<b>Rescue Solutions Int'l</b>	<b>ResQmax Line Thrower</b> 	<ul style="list-style-type: none"> <li>• Designed to deploy a line or a floatation sling.</li> <li>• Can be outfitted with illuminated projectile.</li> <li>• Operates on compressed air at 3,000 psi (207 bar).</li> <li>• Compressed air contained within projectile.</li> <li>• 122-meter range.</li> <li>• Not SOLAS approved.</li> <li>• Cost: \$2,250.</li> </ul>
<b>Restech Norway</b>	<b>PLT SOLAS</b> 	<ul style="list-style-type: none"> <li>• Operates on compressed air at 2,900 psi (200 bar).</li> <li>• Air chamber within unit has capacity for four consecutive shots.</li> <li>• 230-250-meter range.</li> <li>• Meets SOLAS 74.</li> <li>• Floating line and projectile.</li> <li>• Can be outfitted with illuminated projectile.</li> <li>• Cost: \$3,100.</li> </ul>
<b>Kiwi Rescue</b>	<b>Line Launcher</b> 	<ul style="list-style-type: none"> <li>• Operates on compressed CO2 cartridges.</li> <li>• 80-meter range.</li> <li>• Not SOLAS approved.</li> <li>• Flotation pod intended for ship-to-ship and ship-to-shore tow/transfer.</li> <li>• Cost: \$995.00.</li> </ul>
<b>Nordic Sea Safe/ T-ISS</b>	<b>BLT 250 Line Thrower</b> 	<ul style="list-style-type: none"> <li>• Operates on compressed air at 942 psi.</li> <li>• Air chamber within unit has capacity for four consecutive shots.</li> <li>• 230+-meter range.</li> <li>• Meets SOLAS 74.</li> <li>• Cost: \$1,560.</li> </ul>
<b>Vonin/Line-Thrower Sp/f</b>	<b>L-75 Line-Thrower</b> 	<ul style="list-style-type: none"> <li>• Designed for “everyday use” (originally designed for pair-trawlers).</li> <li>• Operates on compressed air at 147 psi (10 bar).</li> <li>• 100-meter range.</li> <li>• Cost info not available, assumed similar or better than other compressed gas devices.</li> </ul>

It should be noted that the catalog of compressed gas type line-throwing devices provided herein is not exhaustive. Several of the above manufacturers produce two or more models of compressed gas line-throwing devices for commercial sales. Rescue Solutions International and Restech Norway each produce other units marketed to fire departments, rescue organizations, power and mining plants, construction companies, and police and military organizations, in



addition to sectors of the maritime industry. Restech Norway is also engaged in an ongoing research and development campaign. The models listed in the table above are those considered by their respective manufacturers to be the most suitable line-throwing devices in their commercial product line for the subject application of this study. ‘Lesser’ models intended for vessel mooring operations or land-based applications have not been included.

There is noticeably less uniformity, in terms of product design and performance, among compressed gas type devices as compared to pyrotechnic type devices. Compressed gas type devices make use of different propellants (air and CO<sub>2</sub>) and a variety of mechanical/pneumatic systems and projectile designs. They have operating pressures ranging from 10 to 207 bar (147 to 3,000 psi) and stated effective ranges from 80 to 250 meters. Not all compressed gas devices are SOLAS compliant (another contrast with pyrotechnic type devices) and none satisfy USCG requirements without advance special approval. The Restech Norway system and BLT 250 Line Thrower by Nordic Sea Safe appear to offer the best performance in this class of devices, whereas it is not apparent from product data alone if any pyrotechnic type devices outperform the majority of others.

## 2.3 Impulse-projected Type Devices

The first developed line-throwing devices were modified cannons (referred to as “Lyle Guns,” after inventor David A. Lyle) and later, modified military rifles. These devices used a gunpowder charge or cartridge to fire a projectile with light line or cordage attached. Such devices are still in use today, primarily for military applications, as they are reported to have good accuracy.

The USCG developed its first shoulder line-throwing gun (SLTG) in 1935. The gun was a specially modified .30 caliber Springfield rifle, Model 1903. This was eventually superseded by the Mk 87, Mod 0 Line Throwing Adapter Kit (LTAK), which enabled the modification of a Springfield M1903 .30-06 caliber rifle. Today, USCG and other US military branches use the Mk 87, Mod 1 LTAK, which can be used to adapt M14, M16, and M16A1 rifles to propel three different types of butyl rubber projectiles (listed in Table 4) with a nylon cord or “shot line” attached. A Mk 87, Mod 1 LTAK is also available for the M16 A2 and M16 A3 rifles, though the review team was not able to confirm performance specifications for these adapted M16 models.

The British Royal Navy and French Navy have developed their own modified firearm line-throwing devices as well, which include the Schermuly Line Throwing Pistol, the Lee Enfield No. 4 bolt-action .303, the L1A1 Self-Loading Rifle, and most recently in the UK, variants of the SA80 family of gas-operated assault rifles, which can be used with a “soft nose projectile,” presumably to reduce the likelihood of injury (see Figure 5). The Glosten team was not able to confirm performance specifications for any of the above adapted firearms, but their ranges are assumed to be similar to those developed in the US.



**Figure 5 Photo of a British Royal Navy Warfare Specialist officer preparing to fire a soft nose projectile from an adapted SA80 shoulder line throwing gun; photo from [twitter.com/navylookout](https://twitter.com/navylookout)**

All such devices use a blank or “grenade” cartridge which, when discharged, results in the sudden chemical change of a solid substance (i.e., granular explosive or “gunpowder”) into gases. These gases, expanded by the heat of the chemical change, escape through the gun barrel at high velocity and exert tremendous pressure on the base of the projectile, propelling it forward through the air (Reference 10).

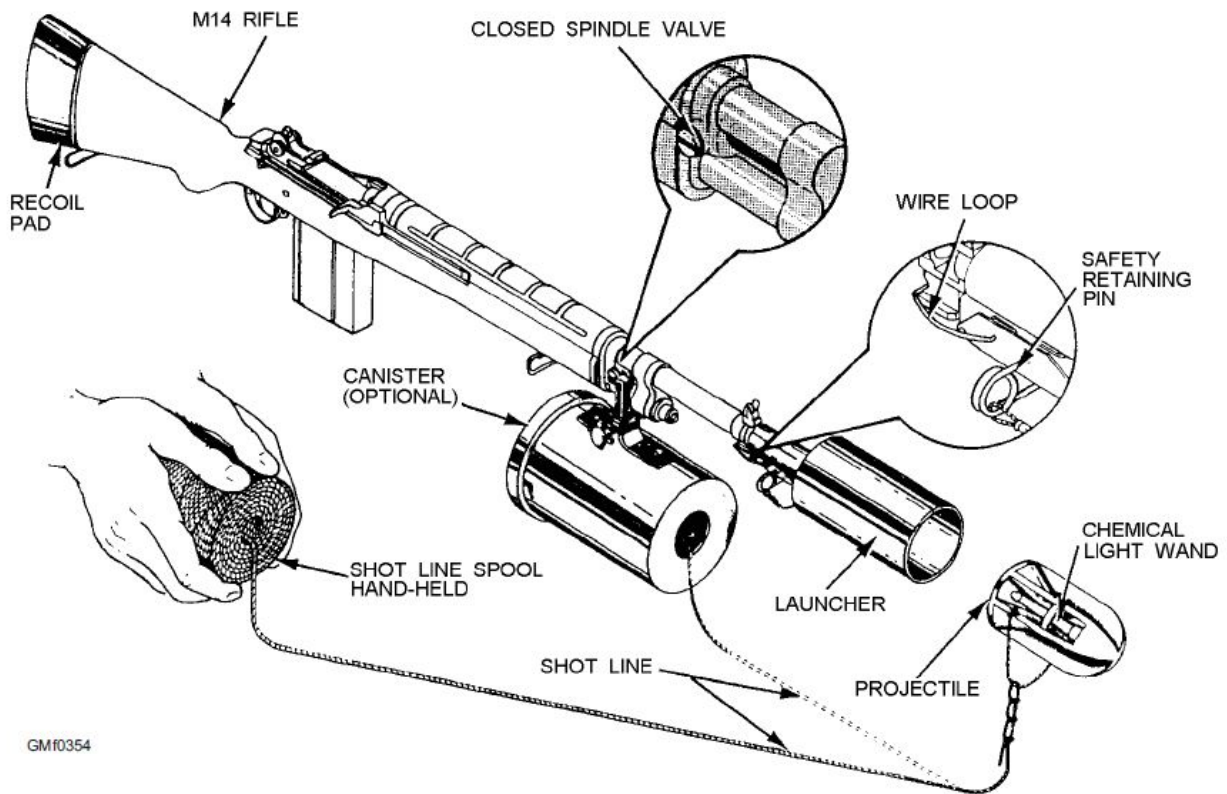

**Figure 6 Mk 87 Mod 1 Line Throwing Adapter Kit shown on M14 rifle; photo from Reference 13**

Excluding environmental factors, the maximum range of modern SLTGs used by USCG and other branches of the US military depends largely on the size and type of the projectile (see Table 4). The most commonly used projectile is the illuminated buoyant projectile (Reference 10).

**Table 4 Mk 87, Mod 1 – max. range by projectile type/size**

Projectile Type/Size	Maximum Effective Range
Illuminated Buoyant Projectile	475 feet (145 meters)
13 oz. Projectile	510 feet (155 meters)
15 oz. Projectile	550 feet (168 meters)

It is noted that the maximum *reliable* range of any of the three projectiles is reported to be approximately 90 yards (270 feet/82 meters) when fired from the M14 rifle and approximately 85 yards (255 feet/78 meters) when fired from the M16 rifle. These ranges are also dependent upon using a dry shot line. A wet line can be used when a dry line is not available, but it will cause the range to be reduced (Reference 10).





**Figure 7** Photo of an impulse-projected type line-throwing device being discharged from the deck of a US Navy vessel; photo from survivalmonkey.com

For a time, Mk 87 LTAKs and pre-assembled SLDTs were available to the private sector and widely used by the US Merchant fleet and US towing and salvage companies in particular. A small company based in Doylestown, Pennsylvania, Naval Company, Inc., also manufactured and sold an impulse-projected type device for many years called the Bridger™ CG85 Shoulder Line Gun Kit. The Bridger™ CG85 kit was USCG approved and included an adapted .45-70 caliber rifle capable of firing a brass rod projectile distances up to 700 feet. It was marketed to the commercial marine and oil and gas industries, as well as construction companies, fire and rescue squads, utility companies, government agencies, and public municipalities. In an October 23, 2019 phone correspondence, the owner of Naval Company, Inc. stated that the Bridger™ CG85 kit is no longer being manufactured, due to discontinuation of the original H&R (now Remington) .45-70 single shot “Handi Rifle,” which was made exclusively for Naval Company, Inc., but that new prototypes are currently under development.

Mossberg (O.F. Mossberg & Sons, Inc.) also once offered *The Mariner*™ Line Launcher (product #50298) and Line Launcher conversion kits (product #90298) for its 500® and 590® model pump action 12-gauge shotguns. The kits consisted of a barrel and cannister assembly, tube extension, 650 feet of shot line, and a projectile shaft that could be fitted with either an extended range projectile head or a buoyant head for marine applications, which had a maximum range of about 250 feet. Mossberg discontinued the Line Launcher conversion kits sometime around 2015.

A number of smaller impulse-projected type line-throwing devices are commercially available, manufactured by companies such as SHERRILLtree, RRT, Specialty Products Co., Rescue Rope, and C-Rich. These devices are primarily intended for the arborist industry and other land-based applications. They are generally not suitable for commercial marine use, and particularly

not for open water ship rescues. One example (SHERRILLtree) has been included in the analysis for reference.

The primary advantages of impulse-projected type devices are:





- Compact design;
- Rechargeability/ reusability at sea and for training purposes; and,
- Comparatively smaller and/or heavier projectiles (some weighing nearly a pound) with very high muzzle velocities, making them less susceptible to wind deflection than other types of line-throwing devices.

For these reasons (primarily the latter), impulse-projected type devices are often strongly preferred by marine salvage and towing vessel operators over pyrotechnic and compressed gas types.

The primary disadvantage of impulse-projected line-throwing devices is the lack of available products and rifle conversion kits for private sector consumers and the need for special training and licensure of designated operators. A background check is required for operation by non-military users while under employment. Impulse-projected devices also have a shorter effective range than other types of line-throwing devices, though this may be offset by the advantages they afford in terms of accuracy and resistance to wind deflection. As firearms, impulse-projected devices are also inherently dangerous and capable of causing serious injuries, especially at close range. They also tend to have high recoil due to the mass of the projectiles, which can cause injury for inexperienced operators. To mitigate the recoil, many impulse-projected line-throwing devices have lead or other metal weights attached to, or embedded in, the stock of the rifle – sometimes as much as two pounds – which counteracts the mass of the projectile as it overcomes inertia. Though effective, this makes the device heavier, even unwieldy for some users.

**Table 5 Impulse-projected devices, images from manufacturer websites and brochures**

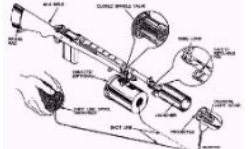
Make	Model	Description
Rescue Northwest	Tetra Line Thrower 	<ul style="list-style-type: none"> <li>• Uses custom blank shot.</li> <li>• Not marine-specific but a float kit is available.</li> <li>• Uses special .308 caliber blank charges.</li> <li>• Range varies, depending on line weight, charge, and projectile.</li> <li>• Maximum range is 137 meters (450 feet).</li> <li>• Does not satisfy SOLAS or USCG requirements.</li> <li>• Available for immediate purchase online.</li> <li>• Cost: \$1,500.</li> </ul>

Make	Model	Description
<b>Naval Company Inc.</b>	Model CG85 Bridger™ Line Throwing Gun Kit 	<ul style="list-style-type: none"> <li>• Range of 76 – 210 meters (250 – 700 feet) depending on which line strength/weight is used.</li> <li>• Regulated as a firearm but manufacturer is attempting to develop a ‘non-firearm’ version.</li> <li>• Currently out of production.</li> <li>• USCG approval for 140-lb line strength, 150-meter max range version.</li> <li>• Does not satisfy SOLAS requirement.</li> <li>• Cost: \$1,775.</li> </ul>
<b>Unknown</b>	Mk 87, Mod 1 Line Throwing Adapter Kit (LTAK)  	<ul style="list-style-type: none"> <li>• Same equipment used by USCG and other branches of the US military.</li> <li>• Utilizes modified M-14 and M-16 rifles.</li> <li>• Not commercially available.</li> <li>• Complete performance specification not publicly available.</li> <li>• Max range with floating illuminated head: 145 meters (475 feet).</li> <li>• Cost info not available, assumed similar or better than other impulse-projected devices.</li> </ul>
<b>Mossberg</b>	500/590 Mariner™ Line Launcher 50298 and Conversion Kit 90298 	<ul style="list-style-type: none"> <li>• Uses modified Mossberg 12 ga. 500® and 590® pump-action shotguns.</li> <li>• Fires two projectile heads (distance head and floating “bottle” head) mounted to the end of a metal shaft.</li> <li>• Max range with floating head: 76 meters (250 feet).</li> <li>• Kits are no longer in production and not readily available.</li> <li>• Cost info not available, assumed similar or better than other impulse-projected devices.</li> </ul>
<b>SHERRILL tree</b>	Big Launcher 	<ul style="list-style-type: none"> <li>• Designed for arborist use but has been adapted for water rescue with floating projectile.</li> <li>• Uses blank ammo, similar to other impulse-projected type devices.</li> <li>• Uses .22 caliber blank charges.</li> <li>• 15 – 40 meter (50-125 feet) range, depending on charge (cartridge size).</li> <li>• Cost: \$430.00.</li> </ul>



## 2.4 Airborne and Waterborne Drones

As drone technology continues to advance at a rapid pace, its potential utility and applicability across a broad range of marine operations is increasingly recognized. Drones may offer significant operational advantages for applications such as: ice navigation, search and rescue, salvage and marine firefighting, and medical evacuation. At this time there are no commercially available drones designed specifically for ship-to-ship line transfers at sea, but prototypes have been developed and already put into practice (see Reference 27).



**Figure 8** Photo of a prototype waterborne drone for delivering a messenger or towline to stranded/grounded vessels; this unit is constructed of a Yamaha 350Li Seascooter mounted to the bottom of a molded high-density polyethylene surfboard

Airborne and waterborne drones may allow passage of lines in cases where it is unsafe for responding vessels to approach within the firing range of traditional line-throwing devices. Airborne drones may be particularly useful for groundings and other salvage operations where the water body surrounding the stricken vessel is non-navigable due to hazards such as breaking surf or exposed rock/reef. Waterborne drones may operate on the water surface, or sub-surface. In either case, waterborne drones are less susceptible to wind deflection than airborne drones or projectiles and may prove invaluable in high wind events where the effectiveness of airborne drones and conventional line-throwing devices is compromised. Drones can also be used repeatedly, but not continuously. Batteries should be replaced or recharged between deployments to maximize operating time and ensure safe recovery.

Apparent disadvantages of using airborne and waterborne drones for line transfers at sea include: lack of availability, high initial cost (and replacement cost, in the event of drone loss/damage), special training and licensure of drone operators with limits on legal operating areas, limited battery life, and limiting environmental conditions for successful drone operation and recovery.

## 2.5 Surface Float Lines

Another method for passing a line between vessels at sea is to deploy a floating messenger line into the water, to be retrieved from the surface by the crew of the receiving vessel (typically the responding towing vessel). The primary advantage of this type of system is that it is well suited for stormy conditions where line firing devices are less effective, and it may be deployed in advance of the arrival of the responding vessel. Float lines also eliminate the need to initiate a connection with cordage or light line, then bend it to a larger diameter messenger, as with airborne projectiles. By skipping this step, float lines can save critical time in an emergency scenario. This also may prevent the towing vessel from having to closely approach the disabled vessel, which may be drifting downwind and/or moving violently due to environmental forces (wind and seas). In circumstances where time is absolutely critical (i.e., grounding appears imminent), it may be possible, and prudent, to deploy the actual towline into the water (if positively buoyant), which the responding tug can recover and connect directly to its tow wire.

Float lines are simple and quick to use and work reliably provided they are deployed properly and have adequate buoyancy and drag to allow the line to draw out on the water's surface. For these reasons, a float line is the preferred method of line transfer of nearly all the salvage and emergency tug operators interviewed by the review team. It is a particularly good choice when sea conditions are rough. It is also maintenance free and long lasting if stored properly.

The primary risk with the use of a float line is fouling in the propeller of the responding tug during recovery. Airborne projectile type line-throwing devices (pyrotechnic, pneumatic, or impulse-projected) introduce less propeller fouling risk, as the attached cordage is light and extremely unlikely to cripple the tug if it becomes wound around the propeller hub.

Another disadvantage of a float line is that it requires movement to stream out on the surface such that it is retrievable from a distance. If deployed from the disabled vessel, the vessel must be drifting downwind, or there must be adequate current velocity to carry the end downstream. Even with adequate drift speed/current velocity, care must be taken that the float line does not become trapped alongside the ship, either due to suction, or by improper deployment onto the vessel's lee side. To avoid this problem, float lines are often outfitted with a small sea anchor or other drag device near the distal (bitter) end.



**Figure 9 Photo of a Coppins Para Sea Anchor spliced onto the body of a floating retrieving line at the Samson Rope factory in Ferndale, WA**

If deployed by the responding tug, the best method, if it can be done safely, is to tow the floating line astern and around one end of the disabled vessel where it can be retrieved by crewmembers on deck.

If winds are light and sea conditions relatively benign, other methods of towline deployment should be considered.

**Table 6 Surface float lines, images from manufacturer websites and brochures**

<b>Make</b>	<b>Model</b>	<b>Description</b>
<b>Samson Rope Technologies</b>	EVATS™ (Emergency Vessel Attachment & Towing System) Retrieving Line Assembly  See Figure 10 below.	<ul style="list-style-type: none"> <li>• 100-meter messenger line (can be varied if desired) with 1.5 meter diameter drag anchor.</li> <li>• Lightweight, high-strength (HMPE fiber) construction.</li> <li>• Positively buoyant, “Hi-viz” color, strobing buoy.</li> <li>• Cost: \$2,500, strongly dependent on material selection and system component selection.</li> </ul>
<b>Cortland</b>	ETS 450 Retrieving Line  See Figure 11 below.	<ul style="list-style-type: none"> <li>• 122-meter messenger line (can be varied if desired) with optional sea anchor.</li> <li>• Lightweight, high-strength (HMPE fiber) construction.</li> <li>• Positively buoyant, “Hi-viz” color, strobing buoy.</li> <li>• Cost: not available, assumed similar to EVATS.</li> </ul>

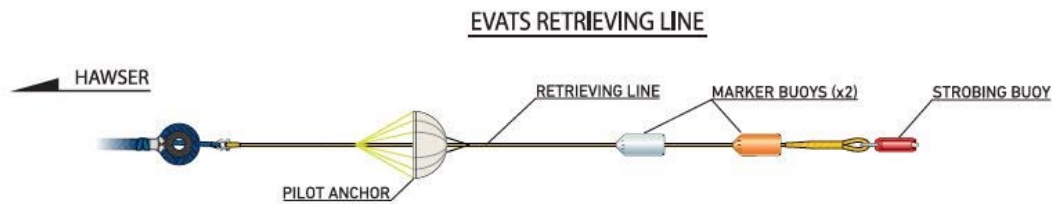

Figure 10 Samson, EVATS™ Retrieving Line assembly



Figure 11 Cortland ETS 450 containerized for storage



---

## Section 3 Regulatory Review

The Glosten team performed a review of existing International Maritime Organization (IMO) and USCG regulations with respect to technologies/methods for passing messenger lines to vessels for emergency towing purposes. We also reviewed all available standards and/or guidance documentation from the Oil Companies International Marine Forum (OCIMF) and major classification societies, as well as state legislation on emergency towing.

### 3.1 International Regulations

The IMO has several regulations and guidelines governing the carriage and capabilities of line-throwing appliances on board ocean-going, SOLAS-certified vessels.

SOLAS is the acronym for the International Convention for the Safety of Life at Sea. The SOLAS Treaty (Reference 19) and its various amendments is the codification of lifesaving equipment best practices developed by the IMO. The aim of SOLAS is to ensure that the merchant ships of the world meet a minimum standard of safety. The USCG enforces SOLAS for the US SOLAS specifies that ships subject to its requirements must be provided with a line-throwing appliance complying with the requirements of Section 7.1 of the Life-Saving Appliances (LSA) Code, and that detailed instructions and training aids shall be provided in the ship's training materials.

The LSA Code (Reference 12) is also an IMO document, which provides international standards for the life-saving appliances required by the SOLAS Convention. The LSA Code indicates the requirements for a line-throwing appliance to be considered "compliant" for the purpose of SOLAS. According to the LSA Code, a line-throwing device must be accurate, have four projectiles and four lines with an effective range of 230 meters and a minimum breaking strength of 2 kN, and include clear instructions.

The Maritime Safety Committee Resolution No. MSC 81.(70) governs the testing of life-saving appliances and prescribes the tests to apply to life-saving devices in order for them to satisfy SOLAS and LSA Code requirements (Reference 18). A manufacturer must test their line-throwing appliance to ensure the device functions correctly, is strong enough, works through a range of temperatures, is well labeled, and has safe and functioning pyrotechnics.

### 3.2 (US) Federal Regulations

46 CFR is a chapter of the United States Code of Federal Regulations devoted entirely to the regulation of shipping (Reference 2). 46 CFR requires line-throwing appliances to be carried on board a number of different vessel types, including certain towing vessels (46 CFR §141.385), mobile offshore drilling units (MODUs, §108.597), and offshore support vessels (OSVs, §133.170), as well as US ships on international voyages over 500 ITC tons, similar to the requirements of SOLAS (§199.170). Most vessels are required to carry pyrotechnic-type devices similar to those required by SOLAS, with four projectiles, each with 450-meter-long lines attached. MODUs that are not in international service and all types of OSVs are permitted to have impulse-projected type devices with 180-meter-long lines. All of the required device types must meet Coast Guard requirements and undergo an approval process which is also dictated in 46 CFR (§160.031 and §160.040).

Devices that do not explicitly meet the USCG requirements, such as compressed-gas-powered devices, may obtain special approval from USCG via a variance for compliance with requirements set forth in 46 CFR. 46 CFR § 160.040-2, paragraph c) reads, "[a]lternate

arrangements which meet the performance requirements of this subpart will be given special consideration. Several of the compressed gas devices reviewed in this study meet the device performance requirements for USCG regulations, a vessel owner looking to use one of these devices need only apply to obtain special approval.

### **3.3 (US) State Regulations**

The Glosten team is not aware of any state regulations related specifically to the carriage or use of technologies and/or methods for passing messenger lines or toelines between marine vessels, with the exception of minimum criteria for the Washington State Emergency Response Towing Vessel (ERTV) stationed in Neah Bay, which states only that the tug shall carry a line-throwing device “capable of passing a suitable messenger line to a disabled vessel from a distance of at least 100 feet in 40-knot winds” (Reference 17). It should also be noted that the minimum criteria for the Neah Bay ERTV are not actually codified in Washington Administrative Code. Rather, these are contractual requirements established by the ERTV Control Board, composed of local shipping industry stakeholders and representatives.



---

## Section 4 Literature Review

In addition to vendor materials and applicable regulations, the Glosten team also performed a review of general literature available on technologies and methods for passing lines between vessels at sea, including, but not limited to, those passed by hand, heaved or thrown aboard, projected by various means, or deployed and retrieved from the surface of the water. The primary finding of this exercise is that there is an overall lack of published materials on this important topic and particularly a lack of any guidance on the best uses for each device type, or how to select the most appropriate type of device for a certain application or set of circumstances. Relevant information from the literature review is summarized below.

Literature reviewed on the topic of passing lines between vessels at sea is cataloged in the Reference List on Page iv.

Multiple articles made reference to the fact that line-throwing devices are difficult to use. The Canadian Search and Rescue Seamanship Reference Manual (Reference 20) describes the use of line-throwing appliances only briefly, but mentions that crosswinds will deflect the line to leeward and make it difficult to put it where one intends to, so users should be prepared to discharge line-throwing devices multiple times. A description of lessons learned from a rescue training exercise conducted in Alaska (Reference 4) identified a need for clear procedures and adequate supplies for “follow-up” line gun attempts during rescue operations, indicating that the need for multiple attempts is likely and can be a source of confusion during rescue operations and other practical applications. An article on the history of line-throwing devices, itself dated 1945 (Reference 15), highlighted the fact that attaining a towing connection via a fired messenger line can be difficult in heavy sea states if one of the vessels is disabled. This article also indicated that most of the line-throwing devices currently in use (i.e., in 1945) are similar to those first developed over 200 years ago. While there have been technological advancements since that time, particularly in way of pyrotechnic and pneumatic type line-throwing devices, the basic method of deployment is the same, and the field performance of more modern devices is not appreciably better than those available in 1945.

Another theme in the literature was the danger of line-throwing devices. This was mentioned specifically in the debrief from the Alaska training exercise (Reference 4), and reinforced by an accident report from the International Marine Contractors Association (Reference 11), describing the accidental activation of a rocket type line-throwing device below decks, leading to injury of a crewmember (see Figure 2). The Canadian Search and Rescue Seamanship Reference Manual (Reference 20) also specified that these devices are very powerful and should always be treated as firearms, regardless of type. The US Navy has drafted instructions for firing a rifle-style (impulse-projected type) line-throwing gun, published in their Small Arms chapter for the Mineman training manuals (Reference 13), alongside instructions on the use of pistols, machine guns, and grenade launchers.

The OCIMF Recommendations on Equipment for the Towing of Disabled Tankers (Reference 16) mentions one specific danger with line-throwing guns when firing the device over a disabled tanker. If the vessel has oil on deck or a gaseous hydrocarbon cloud surrounding it, use of a pyrotechnic line thrower could cause a fire or explosion. For this reason, the OCIMF recommends the use of pneumatic (compressed-gas) -powered devices for emergency tanker salvage operations.

Although specific guidance on the comparison and selection of line-throwing methods and devices was virtually absent in the literature, several of the reviewed documents implied that line-throwing guns should only be used when absolutely required. This would then dictate that

multiple line-passing methods and tools should be available to a vessel, such that the type of method best suited to the situation can be utilized (see Section 5 for additional discussion on this topic).

The literature also reinforced that whatever type of line-throwing device one has, it is most important to be familiar with its use. This point was reiterated in Reference 20, Reference 4, and in a manual on emergency towing best practices put out by the San Francisco Harbor Safety Committee (Reference 5). Reference 5 also incorporated the IMO Guidelines for Owners/Operators on Preparing Emergency Towing Procedures, which specifies that emergency towing equipment and procedures must be identified in advance.

---

## Section 5 Case Study Review

To pull together lessons learned from actual in-practice emergency towline deployment operations, the Glostén team researched a number of recent loss-of-propulsion events occurring in the Aleutian Islands, the Gulf of Alaska, and the Canadian territorial waters off British Columbia. This exercise is an important step in the BAT Review process to gain information on the realities of actual operations, which often uncover unforeseen factors not identified in planning and drills. Wherever possible, interviews with crew directly involved with the operations were conducted to obtain information from their experiences. Logs, situation reports, and retrospective after-action reports were also reviewed, where available. Each case study below features a general incident description, followed by lessons learned pertinent to the subject of this study.

It is further noted that the 2004 grounding of the bulk carrier, *Selendang Ayu*, off Unalaska Island was intentionally not developed as a case study for this report, as the incident occurred more than 15 years ago and, in addition to being well-understood throughout the maritime community in Alaska, the *Selendang Ayu* evolution is assumed to have played a role in the basis for this study.

### 5.1 M/V *Laura Maersk*

#### 5.1.1 Incident Description

On Friday night, July 14, 2017, at about 1700 hours local time, the 872-foot container ship *Laura Maersk* lost power north of Akutan in the Aleutian Islands and began to drift towards shore. The vessel contacted the USCG Sector Anchorage command center and requested assistance. There was patchy fog in the area with southwesterly winds, 10-15 knots. Seas were approximately 1.2 meters (4 feet), forecast to increase to 1.5 meters (5 feet) during the evening hours. The vessel was drifting at approximately 1.9 knots towards land. Estimated time until grounding was 4 hours (Reference 6).

USCG reported the container ship *Laura Maersk* “adrift” at around 2000 hours on Friday night. USCG ultimately federalized the response and deployed air support and the cutter *Midgett* to the distressed vessel. USCG then contracted Resolve Marine Group’s *Makushin Bay* and the tugs *Millenium Falcon* and *Gretchen Dunlap* (which agreed to take the state-owned Alaska Emergency Towing System [ETS] on board). All responding vessels deployed from Dutch Harbor, Unalaska, approximately 32 miles away (Reference 6).

By 0030 hours Saturday the *Laura Maersk* was approximately 7 nautical miles off the coast, and according to the Alaska Department of Environmental Conservation, was in danger of going aground by daybreak (Reference 6).

*Millenium Falcon* arrived on-scene first and, owing to the relatively benign weather conditions, was able to arrest *Laura Maersk*’s drift (at a distance of about 5.5 nautical miles off Akutan) by pushing on the ship’s transom. *Gretchen Dunlap* was still in Dutch Harbor at this time, as the designated equipment for moving the Alaska ETS from storage and loading it on board the tug (believed to be a boom truck) was out of service for maintenance. The Dutch Harbor Port Authority had not made alternate arrangements for emergency mobilization of the ETS during this time. *Gretchen Dunlap* eventually got underway with the ETS from Unalaska at 2220 hours. The estimated time to intercept *Laura Maersk* was 0120 hours Saturday morning (two hours run time) (Reference 6).

In a phone interview on October 22, 2019, Captain Brady Hogevoll of the *Gretchen Dunlap* recounted the rest of the events. When *Gretchen Dunlap* finally arrived on-scene, Captain Hogevoll, took a visual survey of the ship and then got into position for deployment of a line-throwing device, approximately 40 yards off the ship's starboard bow, to windward. The device was a pneumatic type, believed to be a ResQMax Line Thrower.

The first attempt with the line-throwing device was successful. The ETS system was then deployed, with the proximal end shackled into the tow wire socket on the tug. The entire process took less than 40 minutes.

*Millenium Falcon* assisted in turning the ship and building forward momentum, initially. Captain Hogevoll eventually paid out five or six wraps of tow wire and towed the ship into Broad Bay, near Dutch Harbor, with the tug working only about half-ahead (50% power) for the transit. The tow was uneventful and took about 8 hours to complete.



**Figure 12 Tug *Gretchen Dunlap* with the 872-foot container ship *Laura Maersk* in tow; photo courtesy of Dunlap Towing**

Captain Hogevoll reported that weather conditions at the time of the events described were basically as good as they get, and that getting connected to the ship and taking her in tow as quickly as they did was directly attributable to their familiarity with the Alaska ETS system and conducting routine deployment drills and exercises.

### **5.1.2 Lessons Learned**

The *Laura Maersk* evolution off Akutan was a significant near-miss event for western Alaska; but unfortunately, it has not been widely regarded as such, likely due to the fact that the rescue effort (apart from *Gretchen Dunlap's* delayed departure out of Dutch Harbor) went about as smoothly as it possibly could have. The line-throwing device was used successfully on the first attempt and the crews on board both vessels experienced no real difficulty in getting the synthetic towline connected. The task was carried out safely and remarkably quickly. To an extent, this is indeed attributable to the familiarity of the tug crew with the ETS system and use of the line-throwing device, as Captain Hogevoll attested in his October 22 interview. However, it must be noted that the probability of a vessel loss-of-propulsion event coinciding with such

calm conditions in the Bering Sea is remarkably low, as is the probability of such an event occurring just 32 nautical miles from the only available towing vessels in the Aleutian Archipelago. Taking this into account, it is not difficult to imagine how the evolution might have gone differently, had it occurred on another day, or at a more remote location.

The most important lessons learned for the purposes of this study are:

- Simply carrying line deployment BAT on board a marine vessel does not ensure the ability to establish a messenger line connection to another vessel either safely or efficiently. Vessel crews must be properly trained and familiar with the devices on board for this purpose and participate in routine training exercises in which the devices are actually activated or discharged.
- As weather conditions become more severe, or as the rescue effort becomes more challenging due to other factors (e.g., lack of sea room/proximity to land, the condition of the disabled vessel), the importance of having line deployment BAT on board, with crewmembers trained and ready to use it, becomes increasingly critical.

## **5.2 M/V *Ecofaith G.O.***

### **5.2.1 Incident Description**

On February 26, 2017, the 751-foot, 81,882-deadweight ton bulk carrier *Ecofaith G.O.* was en route from China to Prince Rupert, Canada, via South Korea, when the vessel became immobilized due to intermediate shaft breakage. The breakage caused the shaft to shift out of position, resulting in seawater ingress into the engine room (Reference 22).

The incident occurred about 214 nautical miles south of Kodiak Island, Alaska and about 660 nautical miles from Prince Rupert. The vessel was in an in-ballast condition at the time, carrying no cargo. Shipboard generators remained operational (Reference 22).

As the appointed salvor, Tsavliris and its partners/subcontractors Resolve Marine Group and Alaska Maritime Agencies immediately started making arrangements for an emergency tow of the vessel (Reference 22).

Foss Maritime was contracted to provide assistance on the morning of February 27 and the tug *Michele Foss* was underway from Pier 90 in Seattle within 12 hours. Captain Donald (Dwayne) Whitney was in command of the tug (Reference 21).

The plan involved towing the disabled vessel to Dutch Harbor, Unalaska for emergency attendance, underwater inspection, and temporary repairs. Eventually, the vessel would be towed to a shipyard in China for permanent repairs.

In an October 21 phone interview, Captain Whitney explained that he opted to run up the Inside Passage and east of Haida Gwaii, via Hecate Strait, rather than going up the west side of Vancouver Island and Haida Gwaii. The intent of this decision was to take advantage of the more protected waters of the inside passage, which would allow the tug to achieve a higher running speed and thereby reduce the total time to intercept.

*Michele Foss* arrived on March 4, 2017, intercepting the ship at a position approximately 220 nautical miles due west of Dixon Entrance. They arrived just before nightfall and conditions were rough. Because the ship did have electrical power, enabling deck machinery to remain operable, the original plan to take her in tow with hard gear (2-<sup>3</sup>/<sub>4</sub>-inch stud link chain) was upheld. However, with conditions as rough as they were and darkness approaching, Captain



Whitney determined it was not safe to make a close approach and attempt to pass chain at that time.

Because the ship was not in immediate danger of grounding, Captain Whitney also opted not to pass a synthetic towline to hold the ship in position (temporarily), but to instead simply wait for daylight, and for conditions to abate. Foss Maritime Port Captain, Henry Palmer, later stated, “[the crew] upheld the Foss safety culture and waited until the weather calmed down enough to make the connection without putting anyone or anything at risk” (Reference 21).

The ship was reportedly taking on water through the stern tube at a rate of around 70 m<sup>3</sup>/hour and the crew was running multiple pumps continuously. Water was being discharged from several overboard discharge points. On his initial visual inspection of the casualty, Captain Whitney could see that the ship’s propeller was sitting hard-against the leading edge of the rudder, which was apparently the only thing keeping the tailshaft from sliding out completely. Fortunately, shipboard pumps were able to keep up with the flooding.

Though Captain Whitney opted not to take the ship in tow immediately on arrival, he did make arrangements to pass the ship some hardware (a large bell shackle) for making up the tow the following day. To accomplish this gear transfer, the ship deployed a polypropylene mooring line (i.e., a makeshift float line) into the water from the ship’s bow, which streamed out upwind as the ship drifted in the trough. The tug recovered the floating line from a safe distance, about a ship length away, using a grapple and then attached the bell shackle (see Figure 13). The ship’s crew retrieved it by hauling in on the polypropylene line with one of the mooring winches.



**Figure 13** Photo of the crew on board *Michele Foss* recovering a float line deployed from the deck of *Ecofaith G.O.* on the evening of March 4, 2017; photo courtesy of Foss Maritime

After daybreak on March 5, *Michele Foss* stood by for approximately 9 or 10 more hours before conditions improved enough to allow them to make a close approach. Captain Whitney first approached the ship's bow from windward and the crew attempted to pass a messenger by way of a Pains-Wessex pyrotechnic type line-throwing device. The shot was fired near-vertically (see Figure 14) and the wind was still moderate (around 15 knots) at the time. Aimed in this manner, there was sufficient windage on the projectile that it was deflected well downwind, clear of the ship's bow, and into the water.



**Figure 14** Photo of the initial (missed) shot from *Michele Foss* to *Ecofaith G.O.*, using a Pains-Wessex pyrotechnic type line-throwing device; photo courtesy of Foss Maritime

Prior to a second attempt, Captain Whitney repositioned the tug nearer to the ship's midbody to account for the expected wind deflection. The second attempt was successful.

Once the initial cordage connection to the ship was made, Captain Whitney positioned the tug near the ship's bow on the upwind side, at a distance of approximately 20 feet from the bulbous bow, directly under the hawsepipe.

Captain Whitney was able to hold this position for approximately 15 minutes, backing downwind as the ship drifted, to keep the tug as close as possible. From this position, a larger messenger line was passed and shackled into the 2-<sup>3</sup>/<sub>4</sub>-inch stud link chain carried on board the tug. It is not known what machinery on board the ship was used to hoist the chain to the main deck, but it struggled to lift the weight and haul the end-link through the centerline chock.

Eventually, Captain Whitney allowed the tug to “flop” and lie alongside the ship's starboard side while the chain was being secured on the fo'c'sle deck.

Like most non-tank vessels, the ship had no Smit bracket or dedicated emergency towing fitting of any kind; thus, the ship's crew had to improvise. Ultimately, the 2-<sup>3</sup>/<sub>4</sub>-inch chain was “figure-

eighted” between two sets of mooring bitts and the end link was shackled onto the standing part to effectively “choke” the chain in position.

From the time the initial connection was made with the line-throwing device, it took approximately 45 minutes to 1 hour to establish a secure connection to take the ship in tow.

Prior to getting underway, the ship’s tailshaft was secured to avoid turning/moving and to minimize water ingress. The *Michele Foss* then completed a seven-day tow to Dutch Harbor, arriving safely in Broad Bay on March 10 (Reference 22).

### 5.2.2 Lessons Learned

The *Ecofaith G.O.* evolution occurred in the central Gulf of Alaska and thus the ship never posed a significant grounding risk; however, the situation was quite urgent due to the condition of the vessel, taking on seawater through the stern tube. It was fortunate that metocean conditions were not worse than they were and that the ship’s crew was able to stabilize the situation and manage flooding for 13 consecutive days, until the ship’s eventual arrival in Broad Bay.

There are a number of lessons learned from this sequence of events that are pertinent to this BAT review, detailed below:

- In using SOLAS-approved pyrotechnic type line-throwing devices, wind deflection should be expected, even in moderate wind conditions, and compensated for in taking aim.
- Regardless of the type of line-throwing device to be used, steep or near-vertical firing angles are likely to result in higher degrees of projectile wind deflection, as compared to lower firing angles and flatter trajectories. If firing from the deck of a tug or other responding vessel, it may be advisable to stand off the target vessel some distance to avoid excessively steep-firing angles.
- To the extent possible, users of line-throwing devices should endeavor to aim and discharge downwind for maximum projectile range and accuracy. Firing in a crosswind (perpendicular or near-perpendicular to the direction of the wind) will result in more pronounced projectile wind deflection.
- The best towline deployment technology or method to use at sea should not be dependent on the availability or lack of sea room (i.e., assuming all other factors are equal, the BAT should work well for both 2 miles off the beach and 700 miles offshore).
- A float line can be deployed into the water from a disabled ship in almost any weather condition and should be the preferred first method of line deployment in foul weather for maximum safety/lowest risk and highest probability of success. According to Captain Whitney, float lines should ideally be outfitted with a small sea anchor or other drag device near the end to ensure the line streams out properly away from the ship and doesn’t get fouled or “stuck” near the sideshell.
- If the float line method fails or proves impossible for any reason, it is then appropriate to use a line-throwing device.
- In a phone interview on October 21, 2019, Captain Whitney relayed a strong personal preference for converted .308 and .45-70 caliber rifles (impulse-projected type) over SOLAS-approved pyrotechnic type devices. Despite their shorter firing ranges, he believes the performance of impulse-projected type devices is superior because of their higher projectile velocities which, he attests, makes them much less susceptible to wind deflection.



## 5.3 M/V *Golden Seas*

### 5.3.1 Incident Description

On December 3, 2010 at about 0015 hours local time, the master of the 738-foot Panamax bulk carrier M/V *Golden Seas* reported to USCG that the vessel had lost propulsion and was adrift. The vessel was bound for United Arab Emirates (UAE) laden with rapeseed used in the production of canola oil.

The ship's position at the time of the event was roughly 44 nautical miles northwest of Atka Island, part of the Aleutian archipelago and within the jurisdiction of the USCG Captain of the Port Zone Anchorage, Alaska. Winds at the time were northwest at 40 knots with significant wave heights of 22 feet. Preliminary drift analysis showed the vessel would ground on or near Atka Island within 72 hours.

An Incident Command System (ICS) was established in Anchorage with various stakeholders. The intended primary action was to arrest the drift of the ship and then tow it to a port of refuge for repairs. USCG Pacific Strike Team members were mobilized to Anchorage and the USCG Cutter *Alex Haley*, along with two HH 60 helicopters, were mobilized to monitor the vessel and assist in towing operations. The USCGC *Alex Haley* was transiting from the eastern Aleutian Islands and the helicopters were forward deployed to the town of Adak. C130 air support was not immediately available due to planned maintenance/repairs in progress at the time.

The towing vessel *Double Eagle* was stationed in Adak to provide ship assist services in that port; however, with a propulsion system of less than 1500 BHP, the tug was deemed unsuitable to conduct solo towing operations in the present conditions. Two vessels of interest were identified in Dutch Harbor, both under contract to Shell Offshore, Inc. (Shell). The vessels were the offshore spill response vessel (OSRV) *Nanuq* and the T/V *Tor Viking II*, roughly 400 nautical miles from the casualty. The *Tor Viking II* had on board one of the State of Alaska's Emergency Towing System (ETS) kits.

The crew on board the *Golden Seas* was eventually able to restore propulsion, but at reduced power (lacking the use of the turbocharger on the ship's main engine). This allowed the vessel to control its heading and steam at roughly 3.5 knots. The master opted to steer the vessel into the direction of the wind and seas to reduce vessel motions and put additional distance between itself and the nearby Andreanof Islands.

At 1700 hours on December 3, the *Tor Viking II* departed Dutch Harbor to rendezvous with the *Golden Seas*, having been released from contract by Shell. A second ETS kit was delivered to Adak to go aboard the *Double Eagle*, as it planned on attending the casualty, leaving Adak on December 4. At this point, both Adak and Dutch Harbor were under consideration as potential ports of refuge.

By 1730 hours on December 4, the *Tor Viking II* reached the M/V *Golden Seas*, and the *Double Eagle* had been stood down, as Dutch Harbor was identified as the port of refuge to be utilized. The master of the *Golden Seas* felt enough confidence in the vessel's current state that he refused the acceptance of a tow line. Through a USCG Captain of the Port Order, the vessel was directed to accept a tow line from the *Tor Viking II*. Contract negotiations ensued and were made final, allowing the *Tor Viking II* to render assistance with supplemental towing capabilities.

Metococean conditions at the time of the towing connection were sustained northwest wind at 35 knots and significant wave heights of 24 feet. The *Golden Seas'* ability to maintain heading into the weather played a critical role in facilitating the transfer operations. Even so, the operation

was challenging and required coordination of all involved and the skill of the deck crew on *Tor Viking II* to complete.

A ResQMax line thrower was used to make the initial line connection, fired from a distance of about 130 feet (40 meters) off the port beam of *Golden Seas*. On the first attempt the device “failed to charge” and the projectile was not launched. On the second attempt, the projectile reached *Golden Seas*, but was blowing (deflecting) wildly in the crosswind, and the crew was unable to recover it before it fell back into the water. The third attempt was successful, and the shot line was used to pass across a larger, approximately 1-inch diameter messenger line. The master of *Tor Viking II* then repositioned the vessel directly ahead of *Golden Seas*, in preparation for passing the synthetic line that would be used to take the ship in tow.

Even with the messenger line connection already established, passing the synthetic towline from this position and in such conditions proved difficult for *Tor Viking II*. The master was keenly aware that if his crew rendered too much slack, a bight of towline would drag in the water and potentially become fouled on the anchor flukes on *Golden Seas*; yet, if too little slack was rendered and the towline inadvertently pulled taut, this could part the stopper holding it on deck (on *Golden Seas*) and possibly injure crewmembers working to secure a connection.

Had the *Golden Seas* been truly without propulsion or steering and “in the trough” at the time of line transfer, the effort may have been impossible. After the event, crewmembers on board the *Tor Viking II* expressed doubt that a connection could have been made at all, had conditions been any worse.

Averaging speeds of between 7.0-9.0 knots, the combined tow made its way to Dutch Harbor where repairs were made to the *Golden Seas*, allowing her to resume her original voyage to UAE.

### **5.3.2 Lessons Learned**

This case study highlights several lessons learned that should be taken into consideration in this study.

- The lack of an emergency towline on board the *Golden Seas* required mobilization of an emergency towing package from elsewhere. It was fortunate that the state-owned ETS package was available to load on *Tor Viking II* prior to her departure. Had components similar to the ETS been carried on board the *Golden Seas*, a major component of the towing operation would have been in place already, broadening the radius for “tugs of opportunity” to assist.
- There is not always concurrence that an ‘emergency’ towline needs to be connected to a drifting or disabled vessel. This difference in opinion can leave the crews of the different vessels involved working toward dissimilar goals with respect to establishing a towing connection. Establishing a towing connection is clearly more feasible if all involved are working toward the same goal.
- Vessel control over heading in high seas can play a critically important role in effecting the establishment of a towing connection.
- Even when a vessel is not fully operational, primary propulsion (even at reduced power), bow thruster availability, anchoring techniques, or drift restraints are important tools that can be used to mitigate risk and/or facilitate line transfer.
- To the extent possible, vessel crews should avoid firing/activating line-throwing devices in a crosswind.



## 5.4 F/V *Emerald Sea*

### 5.4.1 Incident Description

At 0430 hours local time on October 25, 2018, the Fishing Vessel (F/V) *Emerald Sea* lost propulsion while entering Ventura Harbor, California, on the return leg of a fishing voyage. The vessel grounded on a sandy shoal near the entrance to the harbor. Another fishing vessel, the local harbor master, and a vessel operated by TowBoatUS Ventura/Channel Watch Marine, Inc., attended the casualty to render assistance.

The crew of the *Emerald Sea* worked to restore propulsion and was soon able to do so; however, *Emerald Sea's* efforts to free itself from the shoal under its own propulsion were at first unsuccessful. The master of the *Emerald Sea* then agreed to take a towline from the Channel Watch Marine vessel, but because the water depth surrounding the *Emerald Sea* was quite shallow, it prevented any vessel offering assistance from making a close approach to the casualty. In the darkness of the harbor entrance, the small towing vessel came within 200 feet of the *Emerald Sea* and prepared to transfer a line. The towing vessel launched a waterborne drone, composed of a Yamaha 350Li Seascooter (an underwater scooter or Diver Propulsion Vehicle [DPV]) mounted to the bottom of a molded high-density polyethylene surfboard with a positively buoyant synthetic towline attached (see Figure 15). The drone used cannot be remotely controlled, but instead is simply turned on, aimed at the casualty, and released with a floating line in tow. Directional stability is provided by the skegs on the surfboard; and though it cannot be steered or make turns, the drone maintains a relatively straight course on the surface of the water upon deployment.



**Figure 15 Image of a waterborne drone delivering a floating messenger line to the grounded fishing vessel, *Emerald Sea* (visible inside the red circle)**

In this case the drone reached the *Emerald Sea* and was successfully recovered by the crew on the first attempt. The towline was connected and both vessels began working together to free the *Emerald Sea*. With the towing vessel pulling full ahead and *Emerald Sea* twisting and backing, the goal was eventually attained.

## 5.4.2 Lessons Learned

Though not a large vessel or a high-profile maritime emergency, this incident demonstrates the successful use of alternative methods to conventional airborne projectile transfer systems and floating line systems. The current at the time was such that a floating line would likely not have reached from one vessel to the other. It was also dark and the area poorly lit; thus, lines launched into the air could have been unable to be seen or retrieved by the crew on *Emerald Sea*. The waterborne drone allowed the towing vessel to remain out of danger, removed the need for personnel to swim through the water, and was easily retrieved by the crew on board the vessel in need of assistance.

## 5.5 M/V *MOL Prestige*

### 5.5.1 Incident Description

On Wednesday, January 31, 2018, the 293-meter (876-foot), 71,902 gross-ton container vessel, *MOL Prestige*, was en route from Vancouver, British Columbia to Tokyo, Japan with 23 crew aboard when a major fire broke out in the ship's engine room, knocking out power to the vessel and injuring five crew members.

The incident occurred at 2100 hours local time, at a position approximately 207 nautical miles southwest of Haida Gwaii, two days after departing the port of Vancouver (Reference 8).

The US-flagged tank vessel *Polar Resolution* responded to the initial distress call and stood by the containership (Reference 9). The Canadian Coast Guard Icebreaker *Sir Wilfrid Laurier* (located 300 miles away at the time) was also dispatched to the scene to assist, eventually relieving the *Polar Resolution* on arrival, approximately 20 hours later (Reference 23).

Fortunately, the fire on board was extinguished shortly after it was reported, suppressed by activation of the ship's engine room deluge system; however, two crewmembers were severely injured in attempting to escape the space.

The Victoria Joint Rescue Coordination Centre (VJRCC), in cooperation with the Canadian Coast Guard, dispatched a CH-149 Cormorant helicopter from Comox to evacuate the two injured crew members. A CC-115 Buffalo (fixed-wing turboprop aircraft) was also dispatched to provide air assistance (Reference 7). The injured crewmembers were successfully airlifted off the ship on Thursday, February 1, and taken to a hospital in Queen Charlotte City.

The ship's owner contracted Foss Maritime to provide towing assistance and the 7,270 BHP/110 TBP ocean tug *Denise Foss* was dispatched from Neah Bay, in northwest Washington, to intercept the stricken vessel. Captain Steve Robertson was in command of the tug. Captain Robertson was interviewed for this study.

Given the remote location of the incident, the *MOL Prestige* was forced to remain adrift for several days while the tug was en route. The Canadian icebreaker *Sir Wilfrid Laurier* continued to stand by during this time. *Denise Foss* arrived at the casualty at 1745 hours on Saturday, February 3, 2018, after sunset and about one hour before dark (Reference 8). Sea and wind conditions were light, so Captain Robertson set straight to work on establishing a connection.

Because the ship's service diesel generators (auxiliary engines) had been knocked out by the fire, *MOL Prestige* was running on a single emergency generator, capable of carrying only small electrical loads (lights, navigation electronics, etc.). All deck machinery was completely inoperable. Taking this into consideration, and with winds forecast to increase, Captain Robertson opted to use a synthetic emergency towing package carried on board the tug, rather than attempting to connect with "hard gear."

For the initial messenger line connection, the crew on board the ship first tried a heaving line, but this did not work at all. Robertson says that he instructed the crew on board the *Denise Foss* to use the pyrotechnic type line-throwing appliance(s) carried on board. The exact make and model of the pyrotechnic devices on board at the time is not known.

With the tug positioned about 75 feet off the bow and slightly to windward, the crew made an initial attempt with the line-throwing device and missed. By this time the wind had already increased, and though sustained wind speeds were only 10-15 knots, the projectile and attached cordage was deflected downwind and over the ship's bow into the water.

For the second attempt, Captain Robertson opted to reposition the tug a bit further up the side of the ship and to windward, to compensate for the expected deflection. The crew fired, again from a distance of approximately 75 feet, and was successful.

As the crew worked to pass the 10-inch circumference (3¼-inch diameter) synthetic hawser up to the ship's fo'c'sle deck, Captain Robertson was able to hold the tug in position about 20-25 feet off the bulbous bow. The ship was drifting backward slightly (away from the tug) as they worked to get connected, which facilitated the process for Robertson and his crew.

For chafe protection in way of the ship's chock, the towing hawser was jacketed with Samson DC Gard™, then wrapped in carpet remnants, and finally, plastic trash bags duct-taped to the body of the line. The bags were then greased to lubricate the line body where it rested in the ship's chock.

The whole process took about an hour before they were "hooked up" and able to actually take the ship in tow.

The tow to Elliott Bay took 8 days to complete at an average speed of 4.3 knots. Due to the ship's size, it proved very difficult for the *Denise Foss* to steer in high winds, and the ship biased heavily to one side while in tow. Despite this, the synthetic towline was in good condition upon final inspection (after arrival), with no significant chafing/abrasion.

The ship was berthed safely alongside Terminal 18, Harbor Island at 2330 hours local time on February 11 (Reference 14).



Figure 16 *Denise Foss* entering Elliott Bay with *MOL Prestige* in tow; photo from [marinetraffic.com](http://marinetraffic.com)

### 5.5.2 Lessons Learned

As in the case of *Ecofaith G.O.*, this incident occurred more than 200 miles offshore during relatively moderate weather conditions and thus the *MOL Prestige* never posed much risk of grounding. It was fortunate that the engine room fire was extinguished relatively quickly and did not spread to other spaces or engulf cargoes. The situation was urgent, nonetheless, due to the time of year (mid-winter) and the expectation of an oncoming weather system, and because the crew had already been on board for several days with the ship running only on emergency power. Three injured crewmembers still remained on board as well.

With respect to the initial response effort involving *Denise Foss*, lessons pertinent to this study are as follows:

- Changing metocean conditions and visibility (daylight) at sea can mean limited opportunities to safely pass a line. To avoid vessel casualties (e.g., drift groundings) and the possibility of related spills and/or other environmental damage, tug crews must have the tools and the know-how to connect to disabled vessels safely and quickly in a range of conditions.
- A heaving line is not an appropriate tool/method for passing a messenger between a disabled vessel and a responding vessel at sea, even in favorable conditions. The range of a heaving line is so short that, to be effective, the tug must position itself very closely, almost directly beneath the disabled vessel's bow, or stern, as may be the case. Due to the relative motions of two vessels at sea but not making way (generally exacerbated when one of the vessels is disabled and rolling in the trough), the use of a heaving line in an offshore rescue effort is, quite simply, bad marine practice. In rough conditions, it puts the tug and her crew at extreme risk, and even when risks can be managed the probability

of successfully passing a line in this manner is low. Multiple failed attempts with a heaving line can result in the loss of valuable time.

- As we saw in the case of *Ecofaith G.O.*, pyrotechnic type line-throwing devices can be susceptible to significant wind deflection, even in 10-15 knot windspeeds. Because tug operators and crews do not generally train and familiarize themselves with the use of pyrotechnic type line-throwing devices (due to cost), missed attempts appear to be common in at-sea rescue efforts. Furthermore, it stands to reason that as wind speeds increase and sea conditions worsen, the likelihood of multiple failed attempts with these types of devices increases.
- Tug crews, particularly those working on board dedicated salvage or emergency response tugs, should conduct routine training and drills with whatever type of line-throwing device is carried on board for emergencies at sea.

## 5.6 **Mobile Offshore Drilling Unit Kulluk**

### 5.6.1 **Incident Description**

On December 27, 2012, at 1145 hours local time, conical drilling unit (CDU) *Kulluk* broke free from her tow while en route from Dutch Harbor to Everett, Washington, roughly 50 miles south of Sitkalidak Island within the Kodiak Island Archipelago. The towing vessel was the ice-classed anchor handling towing vessel (ATHV) *Aiviq*. Both vessels were under charter to Shell.

The *Kulluk* is an unusual design of mobile offshore drilling unit (MODU) specifically built to operate in areas with thick ice floes. It is round in hull form with a sloping smooth hull around the perimeter designed to let pack or drift ice push the hull up, reducing pressure on the hull. The *Kulluk* was manned with an 18-person skeleton crew while under tow. The weather at the time of the incident was southwesterly winds at 20-25 knots. Combined seas were reaching 30 feet. The tow was parted roughly 400 feet from the smit brackets, which connected the chain towing bridle to the *Kulluk's* hull, with the failure of a 120-ton shackle. An emergency tow wire was installed in a normal barge style configuration with breakaway attachments.

After this initial towing gear failure, the OSRV *Nanuq* and the towing vessel *Guardman* were dispatched from Seward, Alaska, to assist in the incident response. Concurrently the USCG Cutter *Alex Haley* was dispatched from USCG Station Kodiak in Woman's Bay, Kodiak. The USCG also allowed the T/V *Alert* to leave its station as a tanker escort vessel in Prince William Sound at the request of Shell and it departed Valdez en route to the casualty.

At 1430 hours, the *Aiviq* was able to pick up and connect to the pre-installed emergency tow wire with the assistance of the crew on board the *Kulluk*. At 1900 hours one of the four main engines on the *Aiviq* shut down. The other three main engines shut down over course of the next few hours. The *Aiviq* remained connected to the emergency tow wire, but only had the propulsion of its bow and stern thrusters to keep away from the *Kulluk*.

During the night, Smit Salvage was contracted to attend the casualty under a Lloyds Open Form (LOF) contract. Global Diving and Salvage, Inc. was engaged by Smit and flew out of Seattle with six salvage personnel direct to Kodiak. Meanwhile a flight of emergency towing and response equipment, along with the Salvage Master and additional crew, left Amsterdam, Netherlands, for Anchorage.

In the early morning hours on December 28, the *Alex Haley* arrived on scene. A phone interview with retired USCG Capt. Buddy Custard, who was the Incident Commander of the ICS at the outset of the response, provided detail on the *Alex Haley's* activities that morning. The cutter



pulled abreast of the *Aiviq* and was able to pass a synthetic mooring style line (using a heaving line) to the disabled *Aiviq*, with the intention of taking the *Aiviq* under a “soft tow” to simply maintain heading into the increasingly worsening seas. However, before the towline connection was fully established, the synthetic towline fouled in one of the propellers on *Alex Haley* and brought the cutter to a disabled condition, drifting toward the *Aiviq* and the *Kulluk*. The other propeller on the *Alex Haley* (not fouled with synthetic line) was eventually able to be engaged, which allowed the cutter to put distance between itself and the other vessels. It eventually returned to Kodiak under partial propulsion for repairs.

By mid-afternoon that same day, the *Guardsman* had arrived on scene. The *Guardsman* was able to establish a towline connection to the *Aiviq* and the linked vessels began to move in a controlled fashion heading into the direction of the oncoming seas. Around that same time, spare fuel injectors, which had been identified as the problem with the propulsion engines on *Aiviq*, were dispatched from Peoria, Illinois on a private jet to deliver them directly to Kodiak.

At 1800 hours, Shell requested the evacuation of the crew on the *Kulluk* by USCG helicopter. Two helicopters were dispatched from USCG Air Station Kodiak to the *Kulluk*. Winds over 50 knots and the pitch and heave motions of the *Kulluk* caused the helicopter pilots to deem the evacuation unsafe at that time and the helicopters left the scene.

At 0530 hours on December 29, the tow wire between the *Guardsman* and the *Aiviq* parted. Two helicopter trips delivered 74 new fuel injectors to the *Aiviq* early that morning and the vessel had all propulsion engines up and running by 1145 hours.

At 0630 hours that morning the *Nanuq* arrived on scene and by 1130 hours was able to connect her tow wire to a mooring wire on the *Kulluk* with the assistance of the crew on board. The two vessels now connected to the *Kulluk* began to tow the rig slowly toward Marmot Bay and sheltered water (see Figure 17).



**Figure 17** *Kulluk* under tow with both *Aiviq* and *Nanuq* connected; photo from Anchorage Daily News

During the afternoon on December 29, the USCG helicopters returned to the *Kulluk* and were able to evacuate all 18 of the crew off the rig. The vessel remained under tow through December 29 and into December 30.

At 1310 hours on December 30, the mooring wire in use as a makeshift towing pendant (connected to the towline on the *Nanuq*) parted and was left hanging down in the water. 20

minutes later the emergency tow wire (on the *Aiviq*) parted and the *Kulluk* was no longer under tow, this time in sustained wind speeds of 35-45 knots and combined seas of 20-25 feet, only 30 miles from the coast of Sitkalidak Island. At 1330 hours the *Alert* arrived on scene. At 1930 hours the *Aiviq* departed the *Kulluk's* position to find sheltered water, in order to access a grapple stowed in the ship's rigging gear locker. Having accomplished this and connecting the grapple to the main tow winch, the *Aiviq* returned to the *Kulluk's* position the following morning, December 31.

At 0110 hours, in darkness, the crew of the *Alert* was able to retrieve the emergency tow wire from the water and connect it to their own 2½-inch tow wire on the tug's single drum tow winch. By 0700 the *Aiviq* was able to grapple the mooring line previously attached to the *Nanuq* and make up for tow. Shortly thereafter, while the rig was in tow, a salvage crew boarded the *Kulluk* by helicopter to begin an assessment of her condition and investigate whether emergency anchors could be deployed to assist in arresting the movement of the *Kulluk*.

A phone interview with Andrew Lawrence, P.E., a naval architect who was part of the team that initially boarded the *Kulluk*, offered insight on the activities conducted. Salvage crews on board had been unable to deploy anchors that would have had any significant effect on the drift of the *Kulluk*. They were, however, able to conduct an assessment of the rig's condition, despite the severe pitching and rolling motion of the vessel under worsening weather. The salvage crews noted that several wire and soft lines with buoys attached had been left overboard by the crew of the *Kulluk*, presumably to assist in transferring lines in the event a vessel was able to get close enough. Upon completion of the condition survey, and having gathered enough information to develop a new plan with respect to emergency towing operations, the salvage crews departed the *Kulluk* by helicopter.

Although both towing vessels were attempting to arrest the *Kulluk's* drift path toward shore, the conditions at this point - winds of 55-60 knots and combined seas of 30-35 feet – continued to drive it closer. The changing heading of the *Aiviq* was putting the *Alert* in irons, leaving her unable to steer/correct course in the rough seas. At 1626 hours the towline connecting the *Aiviq* to the *Kulluk* parted once again. The *Aiviq* moved ahead of the *Alert* and provided some shelter from the incoming seas. This allowed the *Alert* to once again pull directly on the emergency tow wire. The master was running engines close to maximum power and still the distance between the *Kulluk* and the coast of Sitkalidak Island (just 7 nautical miles at this point) was reducing. The *Alert* was being dragged backward at a speed of 2.0 knots, with its 10,192 BHP powerplant beginning to overheat from excessive loading of the main engines. In the early evening hours, Unified Command ordered the *Alert* to release the tow for the safety of the tug and crewmembers on board. Shortly after the *Alert* complied with this order, *Kulluk* grounded on Sitkalidak Island.

Strong winds and seas battered the *Kulluk* as it sat grounded on the rocky shore. When conditions eventually subsided to a point where safe access to the *Kulluk* was possible, salvage crews gained access to the vessel and began to make towing preparations with the emergency towing equipment flown in from Amsterdam, Netherlands. A group of salvors boarded the *Kulluk* via helicopter at the first weather window. The *Kulluk* had sustained significant damage to upper portions of the superstructure and a structural analysis of the helicopter landing pad had to be performed before heavier loads of salvage equipment could be permitted to land.



**Figure 18** Chartered aircraft transport emergency towing components from Anchorage to Kodiak

The plan to free the stranded vessel involved connecting a 10-inch circumference (3¼-inch diameter) high-strength synthetic towline, constructed of Dyneema® HMPE fiber, between the towing bridle on the *Kulluk* and the tow wire on the *Aiviq*. Most systems on board the *Kulluk* were disabled at this point due to damage sustained, but a salvage engineer on board was able to get an air compressor system operating, which allowed the use of air-powered tugger winches on deck.

Preparatory work was completed, along with the advent of favorable tidal conditions, to allow connection operations to commence on January 6. Salvage Officer Kristofer Lindberg was one of the crewmen on board the *Kulluk* overseeing the line transfer operation and was able to provide the following details about the operation in an informal phone interview with the review team.

The towing bridle on board the *Kulluk* had been readied, such that when the end of the 3¼-inch HMPE towline was pulled on board, it could be shackled-in relatively quickly. Though the sea state was much calmer than when the *Kulluk* initially grounded, there were still waves of 10-14 feet propagating into the stranding area. Water depths prohibited the *Aiviq* from getting close to the *Kulluk*, so a staged vessel transfer operation was planned. The lighter draft *Nanuq* was to utilize one of its smaller skimming vessels carried on board to deliver a 1¼-inch diameter messenger line from the *Kulluk* to the *Aiviq*.



**Figure 19** Skimming vessel on board *Nanuq*

Preparatory work commenced on the aft deck of the *Aiviq* with the crew enduring a violent sea state and large amounts of water boarding over the aft deck. Several individuals from the salvage crew performed the deck work on *Aiviq*, while the crew of the *Nanuq* carried out delivery of the 1¼-inch messenger line to the *Kulluk*. The skimming vessel was launched with a deck crane and made its way toward the stranded *Kulluk*. Attempts had been made to deploy a smaller float line from the *Kulluk*, but wind and currents were not favorable for it to reach an area where the skimming vessel could safely access it. This led to the use of a line-throwing device on board the skimming vessel. It quickly became apparent that the individuals on the skimming vessel were unfamiliar with the device, as set up took some time and *in situ* familiarization. The crew on board the *Kulluk* recalled that unfamiliarity with the device and motions on board the skimming vessel while firing contributed to two missed attempts before the projectile/shot line could be recovered on board the *Kulluk*. Fortunately, the device was designed to allow multiple successive attempts. Attempts varied from complete misses to “uncomfortably close” in relation to the receiving crew on board the *Kulluk*. On one attempt, some quick scrambling occurred amongst the crew to get clear of the projectile’s path. The projectile then ricocheted off the drill tower into the area where the crew was huddled. When the third attempt ended with the projectile/shot safely recovered, there was sufficient length of cordage to comfortably allow bending it to the end of the 1¼-inch messenger line. After this connection was made, the individuals in the skimming vessel pulled the end of the messenger line through the water and secured it a deck cleat. They then delivered it to the *Aiviq* as the crew on board the *Kulluk* fed slack into the water. Once the 1¼-inch messenger line was secured to the end of the 3¼-inch towline, a deck mounted tugger winch on board the *Kulluk* was used to haul it back, and thereby recover the end of the towline on board.





**Figure 20 Deck mounted air tugger used to transfer the 10-inch Dyneema from the *Aiviq* to the *Kulluk***

This method necessitated halting the operation several times so that the drum of the tugger winch could be cleared and the body of the line “fresh headed” for another drum’s worth of purchase. Ultimately, the end of the 3¼-inch towline was recovered and shackled into the towing bridle on the *Kulluk*. With the towing connection now established, the master of the *Aiviq* took a light strain and waited for direction from the Salvage Master to begin pulling in earnest.

At this time the crew on board the *Nanuq* realized that they were not going to be able to retrieve the skimming vessel from the water due to sea conditions. The individuals on board the skimming vessel accepted that their only option was to drive to the closest location where they could transfer off the vessel and store it in a sheltered area. Thus, they commenced an unplanned trip to Kiliuda Bay, roughly 20 nautical miles from the casualty site.

At 2210 hours the *Aiviq* was able to free the *Kulluk* from her strand and 12 hours later they arrived in Kiliuda Bay to stabilize the vessel and conduct detailed surveys. By this time, 14 vessels, over a dozen aircraft (both fixed wing and rotary), the USCG, the US Army National Guard, and over 700 people had been actively engaged in the response, which included establishing an emergency towing connection nine separate times.

A final point of interest from the *Kulluk* incident related to line-throwing devices is the difficulty the salvage team had with demobilizing their equipment. Upon demobilization, the line-throwing device had to be sent back to Holland separately from the rest of the equipment, and it had to be shipped commercially. Due to HAZMAT shipping requirements and related documentation, this shipment proved to be very costly.

On March 26, 2013, the *Kulluk* was loaded on the heavy lift ship *Xiang Rui Kou* and brought to Singapore. Repairs were deemed not feasible and Shell decided to scrap the unit in 2014. On February 27, 2014, *Kulluk* was again loaded on *Xiang Rui Kou* and carried to a Chinese scrapyards.

### **5.6.2 Lessons Learned**

The *Kulluk* incident highlights many lessons given the scope of activities undertaken. Those most relevant to the BAT review include:



- The disabling of the *Alex Haley's* propulsion system during the line transfer process highlights potential risks when conducting these operations. When responders suddenly become victims, the incident can grow exponentially worse. Evaluating BAT for topline transfers should include the potential ability to mitigate this risk.
- Multiple methods were used to retrieve lines from the water, including a grapple as used by the *Aiviq* to retrieve the mooring wire that had been utilized as a temporary towing pendant. Having different tools available for different scenarios can be advantageous and can make available different methodologies of operation.
- The duration of the efforts to arrest the *Kulluk* before grounding and the changing weather during that time demonstrates how inclement conditions can be in Alaska waters. These adverse conditions, coupled with the duration of the arrest efforts, taxed the tow wires and vessels to a point where their design performance was compromised. Robustness of equipment should be a factor in evaluating tanker topline deployment in Prince William Sound.
- The *Kulluk* was outfitted with many options for handling and hauling toelines. Despite all these tools on board, most were not available when it mattered most, due to damage and the loss of auxiliary power. This led to the innovative use of an air-powered tugger winch to heave the messenger line on board. One should not assume all equipment on board an oceangoing vessel will be functioning as designed, or even operable during an incident. Thus, technologies and methods for passing a messenger line at sea must not be limited by a single point of failure.
- The unfamiliarity of the *Nanuq's* crew with operation of the line-throwing device was apparent and could have led to a failed operation or injury of personnel. Ease of use for equipment is important, as is routine training of those expected to operate it.
- The ability of the line-throwing device to fire multiple charges in fairly quick succession proved to be invaluable in establishing the towing connection between the *Aiviq* and the *Kulluk*. Had the individuals on board the skimming vessel been unable to “re-load” and make multiple attempts from their position, the entire operation might have failed.
- The inability to retrieve the skimming vessel used to establish the initial messenger line connection forced this asset to leave the salvage effort, and could have posed serious safety risks had the vessel been unable or unsuited to make the 20-mile transit to Kiliuda Bay on its own. Methodology and hardware used for line transfer operations need to match conditions, in terms of design operability.
- The shot line of the line-throwing device used proved to be of suitable length and strength to support the operation. These are important components to be considered.
- The inability of the regular crew to work the back deck of the *Aiviq* in the conditions at the time demonstrated that not everyone on board a vessel has the same “comfort factor” or requisite experience to work effectively in conditions beyond those of normal operations.
- The wind velocity and airborne spray from the ambient sea state and wave impact on the hull prohibited helicopters from landing on the *Kulluk*. These often-used assets cannot always be relied upon on for utilization in all conditions.

Even though tremendous amounts of equipment were mobilized in short order, the problematic shipment of the line-throwing device during demobilization highlights some of the additional factors and limitations certain devices can introduce.

---

## Section 6 Device Evaluation

### 6.1 Methodology

To objectively evaluate the devices identified in Section 2 and determine BAT, the Glosten team used a set of eight evaluation criteria originally developed by the Alaska Department of Environmental Conservation (ADEC). The Glosten team evolved these criteria to incorporate the critical system features and functionalities determined during the Phase 1 research (Reference 27). Glosten then developed subcategories of these criteria, to compare the capabilities of each device on specific attributes. The criteria and subcategories are detailed in Table 7.

**Table 7 BAT scoring criteria and subcategories**

Criteria	Effectiveness	Feasibility	Transferability	Compatibility	Age and Condition	Availability	Environmental Impacts	Cost
<b>Descrp.</b>	What is the effective range, accuracy, and temporal efficacy of the technology /method?	Is it feasible to use this technology /method from an engineering and operational perspective, to include consideration of operational complexity and required training /certification?	Can the technology /method be used across all possible/foreseeable emergency towing scenarios in Prince William Sound/Hinchinbrook Entrance? Can the technology be used effectively in all metocean conditions and at night, or in reduced visibility?	Can the technology /method be operated by any or all members of a vessels crew? Does use of the technology /method require background checks or special certification?	Can the technology /method withstand and perform in the harsh marine environment where it is intended to be used, and does it reliably work as designed? Is the technology /method reasonably easy to maintain in good working order over a 10-year service life?	Is the technology /method commercially available for private-sector marine operators in the volumes that would be required for adoption for Prince William Sound tank vessel operations?	What impact does the use of the technology /method have on maintaining a safe working environment on the deck of either vessel (i.e., deploying or retrieving)?	What is the all-in cost of the technology /method over a 10-year service life?
<b>Subcat.</b>	<ul style="list-style-type: none"> <li>▪ Range.</li> <li>▪ Accuracy / susceptibility to wind deflection.</li> <li>▪ Effect on total time to establishing a secure towline connection, relative to other technologies.</li> </ul>	<ul style="list-style-type: none"> <li>▪ How difficult is the device to set-up and deploy (fire), initially?</li> <li>▪ How difficult is the device to reload /reactivate and re-deploy?</li> <li>▪ Are the projectiles and /or attached lines positively buoyant in seawater?</li> </ul>	<ul style="list-style-type: none"> <li>▪ Can the device be used effectively in high wind and sea conditions?</li> <li>▪ Can the device be used effectively in calm weather?</li> <li>▪ Are the projectiles and /or attached lines lighted and/or of high-visibility color?</li> </ul>	<ul style="list-style-type: none"> <li>▪ Is the device regulated as a firearm, considering there are regulations that restrict some individuals (e.g., those convicted of certain crimes, non-citizens) from using firearms as part of their jobs?</li> </ul>	<ul style="list-style-type: none"> <li>▪ How complicated or onerous is the device is to maintain?</li> </ul>	<ul style="list-style-type: none"> <li>▪ Is the device currently in production?</li> <li>▪ How easy it is to buy the device, including consideration of lead time to delivery?</li> <li>▪ Is shipment of the device regulated or restricted due to the nature or material composition of any components (e.g., firearms, gunpowder, composite propellant, or other hazardous materials)?</li> </ul>	<ul style="list-style-type: none"> <li>▪ Is the projectile deployed or propelled by incendiary or explosive materials?</li> <li>▪ Is the propellant activated within the body of the device, or emitted from the projectile in flight?</li> <li>▪ How safe is the overall process for establishing a towline connection using the subject device?</li> </ul>	<ul style="list-style-type: none"> <li>▪ Does the device meet SOLAS requirements or will a supplementary SOLAS-approved system have to be carried on the vessel as well, for compliance purposes?</li> <li>▪ What is the cost of regular servicing or replacement parts, if any?</li> <li>▪ What is the cost to use the device during regular training exercises?</li> </ul>

After compiling data on each device in each of the subcategories listed above, the Glosten team ranked each device based on its relative performance on each of the eight criteria. Complete device ranks are reported in Appendix A. The criteria themselves were also ranked in order of importance to determine the weight that each criterion should be assigned for final scoring. The criteria rank and weights were determined as indicated in Figure 21.

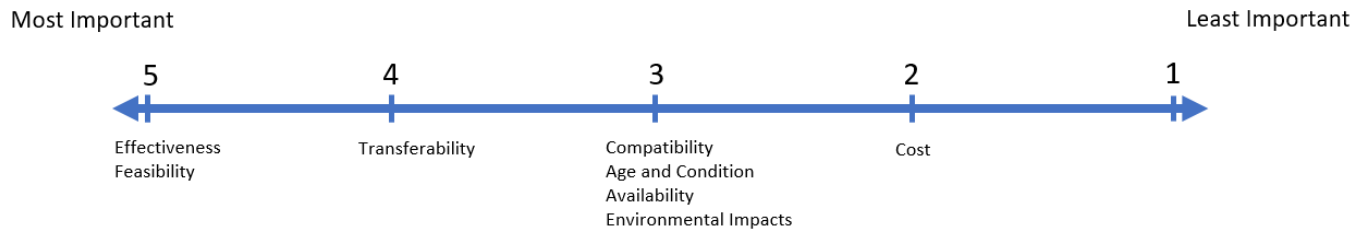

**Figure 21** Criteria ranks and weights

Once the evaluation criteria were weighted in order of importance and the devices were scored on their relative performance on each criterion. The weight of each criterion was then multiplied by the device’s score on that criterion, and each device’s weighted scores were totaled to determine their final score. Final scores were then compared to determine which device(s) constitute BAT.

### 6.1.1 Assumptions

Information on each device was collected from direct conversations with manufacturers or licensed distributors. In cases where manufacturers or distributors could not be directly contacted, data was compiled from documentation available on the internet.

For the **effectiveness** criteria, information on effective range was taken from technical or performance specifications provided by the manufacturer. Given a lack of practical metrics for accuracy/susceptibility to wind deflection, device accuracy was assumed both from manufacturer’s claims as well as from general information about different device types obtained during the technology research and literature review, such as the Canadian Search and Rescue Seamanship Reference Manual (Reference 20). For compressed gas type devices, those with higher design operating pressures were assumed to perform more accurately (i.e., track straighter). Overall towline connection time was determined to be a factor of whether the messenger line is passed directly between vessels, or, as with projectile-based devices, a light cord must be connected first, constituting an additional step.

For the **feasibility** criteria, operating complexity was derived from device operating manuals and from online videos of the various devices being deployed/activated. Difficulty of preparing for a second deployment was determined from instructions in device operating manuals. The incorporation of floating components for each device was determined from the manufacturer’s literature.

For the **transferability** criteria, the usability of a device in both severe and calm conditions was determined from the literature about different device types and from the practical experience of subject matter experts on the Glosten team, as well as those interviewed in Phase 1. Particular considerations included whether a device was highly susceptible to wind deflection, and whether a device required certain environmental forces (e.g., wind and/or current) to work properly. The incorporation of lighted or high-visibility components was determined from the manufacturer’s information.

A device’s **compatibility** for use by all members of the crew was a simple determination of whether the device is regulated as a firearm, either as reported by the manufacturer, or because

the device is clearly a modification kit for an existing firearm. Line-throwing devices regulated as firearms require a background check and thus may not be legally usable for all members of a vessel’s crew. All other devices considered in this report require familiarization, but not specialized training or certification, and therefore scored higher (and equally with one another) on compatibility.

Because it is assumed that any onboard technologies/devices for towline deployment would be purchased new, **age and condition** scores were determined by the maintenance requirements of the device. This was either collected from the device manuals provided by the manufacturers or assumed to be similar for similar device types, in cases where information could not be obtained.

Information on the **availability** of devices was determined by whether the device was safely transportable and readily available for purchase. Safe transportation was a direct factor of whether the device was a pyrotechnic type, and therefore regulated for transport as hazardous material, or was restricted for transport due to being regulated as a firearm. Availability for purchase was determined by online searches and by contacting distributors to determine if a device was available immediately, a special-order item, out of production, or only available in certain countries.

The **environmental impacts** of a device (implications for safety on deck) were determined from details about the nature of the projectile, mainly related to the presence or absence of propellant and the propellant type, and the safety of the overall towline connection process using the subject device. This information was obtained from the general literature about the various device types, information published by the device manufacturers, and from the experience of subject matter experts on the Glosten team.

The **cost** of each device was determined from internet searches and from direct correspondence with device manufacturers and distributors. Where no price information was available, the device was assumed to cost the same as a seemingly identical or similar device for which pricing was available. For devices which do not meet the SOLAS requirements, the cost was calculated to include both the cost of the device in question, as well as the cost of a complete SOLAS compliant kit composed the least expensive readily available pyrotechnic type, the Ikaros. The costs of regular use of the device by the crew for training purposes was also considered, assumed as four shots per line-throwing apparatus per year.

Surface float line package prices are strongly dependent on the material, line lengths, and additional components selected. For the purposes of this report, we have assumed a 100-meter, 1-inch diameter retrieving line, with sea anchor and strobing buoy, for a nominal price of \$2,500. The same price was assumed for both surface float line manufacturers.

## 6.2 Summary of Findings

Scores for each device are listed in Table 8. Complete detailed device scores by category are included in Appendix A.

**Table 8 Score summary**

Manufacturer	Device	SCORE
<b>Pyrotechnic</b>		
Pains-Wessex	Linethrower 250	<b>96</b>
Ikaros	Line thrower	<b>108</b>
Comet	Linethrower 250	<b>96</b>
Huahai Marine Signals	Line Throwing Unit	<b>99</b>



Manufacturer	Device	SCORE
Qindao Good Brother	Line Throwing Appliance PSQ230	<b>94</b>
SHM	Line Throwing Appliance	<b>96</b>
Sea Marine	Linethrower 250	<b>96</b>
Global International	Line Throwing Appliance	<b>96</b>
Matchau	Line Throwing Unit	<b>96</b>
<b>Pneumatic</b>		
Rescue Solutions Int'l	ResQMax	<b>97</b>
Restech Norway	PLT SOLAS US	<b>121</b>
Kiwi Rescue	Line Launcher	<b>107</b>
Nordic Sea Safe/T-ISS	BLT 250 Line Thrower	<b>109</b>
Vonin/Line-Thrower Sp/f	L-75 Line-Thrower	<b>90</b>
<b>Impulse-Projected</b>		
Rescue Northwest	Tetra Line Thrower	<b>100</b>
Naval Company Inc.	Model CG85 Bridger™ Line Throwing Gun Kit	<b>80</b>
Unknown	Mk 87, Mod 1 Line Throwing Adapter Kit (LTAK)	<b>88</b>
Mossberg	500/590 Mariner Line Launcher 50298 and Conversion Kit 90298	<b>79</b>
SHERRILL Tree	Big Launcher	<b>94</b>
<b>Surface Float Lines</b>		
Samson Rope Technologies	EVATS Retrieving Line	<b>112</b>
Cortland	ETS 450 Retrieving Line	<b>112</b>

The Restech Norway PLT SOLAS unit was the top-rated device by the Glostén scoring methods. This unit is a pneumatic line thrower with a range of over 230 meters and four projectiles included, satisfying all SOLAS requirements. The device uses compressed air stored in a cylinder within the body of the unit, at the base of the launch tube. The cylinder holds sufficient pressure for four 230-meter shots and is refilled from a compressor or a separate compressed air tank. Specific advantages of this device include:

- High accuracy and resiliency to wind deflection due to high operating pressure, resulting in high projectile muzzle speed.
- Floating line and projectile.
- The ability to be outfitted with an illuminated projectile.

- The lack of incendiary components or other hazardous materials.
- A passive projectile (not charged with a propellant of any kind).
- Rapid reusability.
- Compliance with SOLAS requirements.
- Relatively low cost upfront costs, with no replacement costs or additional costs associated with using the device in training exercises.

It should be noted that although this device meets the performance requirements of USCG regulations (46 CFR § 160, see Section 3.2), it is not explicitly approved for use by USCG. To obtain this approval, a vessel owner looking to use this device as their required line-throwing appliance must apply for a variance from USCG. For example, the Columbia River-based towing company Shaver Transportation recently identified the Restech Norway PLT SOLAS device as their preferred line-throwing appliance for use on board their tanker escort tug *Samantha S*, and were able to apply for and obtain USCG approval through their local sector.

The two surface float lines tied in our rankings as the next best devices after the Restech PLT. Specific advantages of these systems include:

- Excellent range, limited only by the length of line specified at the time of order.
- Minimal maintenance requirements.
- Long service life (no need to replace unless condition becomes degraded).
- Simple to use and quick to deploy.
- May expedite the towline connection process, as the messenger line is passed directly between vessels (no initial connection with light cordage).
- Particularly well-suited for use in high wind and wave conditions, where line-throwing devices become more challenging to use successfully.

The cost of the two surface float line systems was assumed identical.

The third-place system was the Ikaros Linethrower, which is a pyrotechnic type device. While this system shares many characteristics with the other pyrotechnic type units, it has a few advantages. The Ikaros device uses a positively buoyant line, unlike the other pyrotechnic devices. It also has a higher effective range and a lower cost than other commonly used pyrotechnic devices. However, in order to allow the crew to be able to use these devices several times a year for training purposes, new units would have to be purchased to replace each fired unit, which would become very expensive.

The fourth-place system was the T-ISS BLT 250, which is another SOLAS-approved pneumatically-operated device. This unit has similar advantages to the Restech PLT but with a lower operating pressure and no floating or illuminated line. It does, however, cost less than the Restech PLT. Similar to the Restech PLT, special approval would need to be obtained from USCG in order to use this device as a USCG required line-throwing appliance.

In general, the pyrotechnic devices scored highly on effectiveness, feasibility, and age and condition, due to their advantages in range, ease of use, and ease of maintenance. These devices had low scores for availability, both because they are hazardous cargo and restricted for shipping, and because many of the devices of this type available for sale lack published information available about the device or the manufacturer. They also scored poorly on environmental impacts, which is a measure of safety, because their incendiary propellant fires

from the projectile, making it a potential hazard both upon firing and while intercepting. The most widely available, reputable brands of pyrotechnic devices are more expensive than other more budget-oriented options in this device category. These most common brands scored very poorly on cost after factoring in the complete cost of a SOLAS-approved kit of four devices, the regular replacement of the rocket components, and the costs of replacement units to allow crew training exercises.

Pneumatic units scored highly on their transferability and availability, since the devices in this category function in a wide range of conditions and are readily available through company representatives or online. This category of devices had the widest variability in terms of unit design and function, and the scores reflect this in their variable performance in effectiveness, feasibility, and cost. The units with high accuracy and range scored well on effectiveness, and the units with easy reloading procedures and floating components scored well on feasibility. The units that meet the SOLAS requirements scored very well on cost since they did not have to include the cost of an additional SOLAS-approved system, as long as they obtain USCG special approval.

The impulse-projected devices scored well on their transferability, feasibility, and effectiveness, because these devices have great accuracy even in high winds, are often outfitted with floating components, and are relatively easy to reload. However, the lack of availability of these devices resulted in low availability scores, and the background checks required for use adversely affected their compatibility scores. These devices also scored low on age and condition due to the maintenance requirements to keep them reliably operable in a marine environment, and on environmental impacts due to the safety concerns associated with using gunpowder-charged cartridges to fire heavy projectiles.

Surface float lines scored highly on age and condition due to their lack of required maintenance, and on effectiveness and feasibility due to their simplicity and ease of use. Although they can be problematic to deploy in calm weather, their benefits in high wind and sea condition resulted in high ranks on transferability. These units are easy to obtain and safe to use, earning them high scores on the availability and environmental impacts criteria. The only criterion that these devices did not score highly on was cost.

---

## Section 7 Recommendations

The Restech PLT SOLAS unit offers several practical advantages and is recommended as BAT for Alyeska Pipeline Service Company's Ship Escort/Response Vessel System (SERVS) and/or tank vessel operations in Prince William Sound. The Restech system meets SOLAS and USCG performance requirements, is relatively inexpensive and readily reusable, and will perform reliably for many years with regular maintenance. The lack of incendiary propellant makes it a great option for use on tank vessels. It can also be used in drills and rescue training exercises at virtually zero cost.

It is worth noting that the surface float line systems offer different advantages from line-throwing devices and are arguably better suited for certain (but not all) scenarios, principally high wind and sea state conditions. Although surface float lines cannot be carried in lieu of line-throwing devices due to SOLAS and USCG requirements and do not offer the ability to quickly deploy multiple times if the line becomes fouled, they do offer simplicity and potential time savings in establishing an emergency towing connection, which could be critically important in cases where a vessel drift grounding appears imminent. Surface float lines also do away with the need to position a responding tug near to the bow or mid-body of a disabled vessel. With line-throwing devices, this is generally necessary for passage of the messenger line using the light line/cordage carried by the projectile. In higher sea states, positioning the tug near to the disabled vessel comes with extreme risk to the vessel and crew and should be avoided to the extent possible. By contrast, surface float lines allow a responding tug to recover a ship-deployed messenger line directly from the surface of the water at a safe distance upwind or down-current from the disabled vessel. Surface float lines are also low maintenance, long-lasting systems. For these reasons, vessel operators serving or supporting the Trans Alaska Pipeline System (TAPS) trade should consider outfitting vessels with both the Restech PLT SOLAS unit and a surface float line, to give themselves at least two options for emergency towline deployment for any given scenario. This combined "package" would cost less than \$1000 more than a 10-year complement of the commonly used SOLAS compliant pyrotechnic devices (without considering costs for conducting regular training exercises) and offer considerable advantages over pyrotechnic devices in emergency scenarios.

Also recommended, as a follow-on phase of this study, is a practical trial/demonstration of the top three to five technologies identified in this review, with SERVS/TAPS vessel operators and individuals from PWSRCAC in attendance. Devices could be obtained from system manufacturers or licensed distributors to test their performance on actual vessels in Prince William Sound, or similar operating environment. This would allow operators to obtain a hands-on, practical understanding of the nuances of each system. Field data could be collected on horizontal reach distance and wind deflection for each of the devices, as well as qualitative information about the relative difficulty of charging, deploying, and recharging each device, and best practices for improved probability of successful deployment. This combination of practical experience and data collection could prove vital for validation of the findings of this report, and to facilitate adoption of the BAT for emergency towline deployment in Prince William Sound.

---

## Appendix A      Scoring Matrix



Criterion	Effectiveness	Feasibility	Transferability	Compatibility	Age and Condition	Availability	Environmental Impacts	Cost		
Weight (1-5)	5	5	4	3	3	3	3	2		
Manufacturer	Device	CRITERIA SCORES (1 = very poor; 2 = poor; 3 = moderate; 4 = good; 5 = excellent)							SCORE	
Pyrotechnic										
Pains-Wessex	Linethrower 250	4	4	3	5	4	3	2	1	96
Ikaros	Line thrower	5	5	3	5	4	3	2	2	108
Comet	Linethrower 250	4	4	3	5	4	3	2	1	96
Huahai Marine Signals	Line Throwing Unit	4	4	3	5	4	2	2	4	99
Qindao Good Brother	Line Throwing Appliance PSQ230	4	4	3	5	4	1	2	3	94
SHM	Line Throwing Appliance	4	4	3	5	4	1	2	4	96
Sea Marine	Linethrower 250	4	4	3	5	4	1	2	4	96
Global International	Line Throwing Appliance	4	4	3	5	4	1	2	4	96
Matchau	Line Throwing Unit	4	4	3	5	4	1	2	4	96
Pneumatic										
Rescue Solutions Int'l	ResQMax	4	2	5	5	3	4	3	1	97
Restech Norway	PLT SOLAS US	5	4	5	5	3	4	4	4	121
Kiwi Rescue	Line Launcher	3	5	3	5	3	5	4	2	107
Nordic Sea Safe/T-ISS	BLT 250 Line Thrower	4	3	4	5	3	4	4	5	109
Vonin/Line-Thrower Sp/f	L-75 Line-Thrower	2	2	3	5	3	4	4	5	90

Criterion	Effectiveness	Feasibility	Transferability	Compatibility	Age and Condition	Availability	Environmental Impacts	Cost		
Weight (1-5)	5	5	4	3	3	3	3	2		
Manufacturer	Device	CRITERIA SCORES (1 = very poor; 2 = poor; 3 = moderate; 4 = good; 5 = excellent)							SCORE	
Impulse-Projected										
Rescue Northwest	Tetra Line Thrower	4	4	4	5	2	4	3	1	<b>100</b>
Naval Company Inc.	Model CG85 Bridger™ Line Throwing Gun Kit	4	3	4	1	2	3	3	1	<b>80</b>
Unknown	Mk 87, Mod 1 Line Throwing Adapter Kit (LTAK)	4	4	5	1	2	1	2	5	<b>88</b>
Mossberg	500/590 Mariner Line Launcher 50298 and Conversion Kit 90298	3	4	4	1	2	1	2	5	<b>79</b>
SHERRILL Tree	Big Launcher	2	4	4	5	2	4	3	3	<b>94</b>
Surface Float Lines										
Samson Rope Technologies	EVATS Retrieving Line	4	4	4	5	5	4	4	1	<b>112</b>
Cortland	Emergency Tow Package	4	4	4	5	5	4	4	1	<b>112</b>

---

## Appendix B    Device Datasheets

# Linethrower 250

Art Nos. Complete unit 9160400 · Body and line 9160500 · Rocket 9162700

A self-contained line-throwing appliance consisting of a weatherproof plastic casing with end cap, twist-grip trigger assembly, rocket and line. To comply with SOLAS requirements, four complete rocket and line assemblies (Art. No. 9160400) should be carried on board. The device has a throwing range of between 230m and 250m. A solid propellant is used which guarantees a highly accurate flight path even in strong sidewinds.



Rocket

## Application

The Comet Linethrower 250 is designed for ease of operation in the most extreme weather conditions. It can be used in all situations where a line is required to be passed accurately and quickly, these include:-

- All line-throwing operations at sea between vessels, ship-to-shore, shore-to-ship and shore based rescue services.
- Rescue of swimmers in distress.
- Line carrying across obstacles and rough terrain.

## Operation



1. Remove the front cover and point in the desired flight direction.
2. Pull out safety pin.
3. Aim over the top of target. Be prepared for recoil.
4. Turn grip to left or right to fire.
5. If misfire occurs hold unit in firing position for at least 60 seconds, then dispose of overboard.

## Product Life

- Body and line kit: 9 years
- Rocket minimum 3 years
- Spare rockets are available to replace consumed or time expired rockets.

## Packing & Transport Information

**Body and Line, less rocket** in packing case,  
L 37 cm (14.57 in) x W 27 cm (10.63 in) x H 27 cm (10.63 in)

- Gross weight 4.2 kg (9.26 lb.)
- Net weight 3.6 kg (7.94 lb.)
- Other Information: Non-hazardous

**20 Spare Rockets** in metal tin in a fibreboard box,  
L 37 cm (14.57 in) x W 27 cm (10.63 in) x H 27 cm (10.63 in)

- Gross Weight Max: 13 kg (28.66 lb.)
- Net Weight Max: 10.70 kg (23.59 lb.)
- Net Explosive Content per box : 2.12 kg (4.67 lb.)
- Hazard class 1.4G
- UN 0431
- Proper shipping name: Articles, Pyrotechnic
- Other Information: Cargo Aircraft Only

## Specifications

Projects a line to a nominal range of 250m in calm conditions.

- Length: 33 cm (13.0")
- Height: 31.3 cm (12.3")
- Diameter: 20.5 cm (8.1")
- Gross Weight: 4.7kg (10.36 lb.)
- Net Weight: 4.4 kg (9.7 lb.)
- Rocket Weight Max: 535g (18.9 oz.)
- Explosive Content Max.: 106g (3.74 oz.)
- Line breaking strain: >2 kn

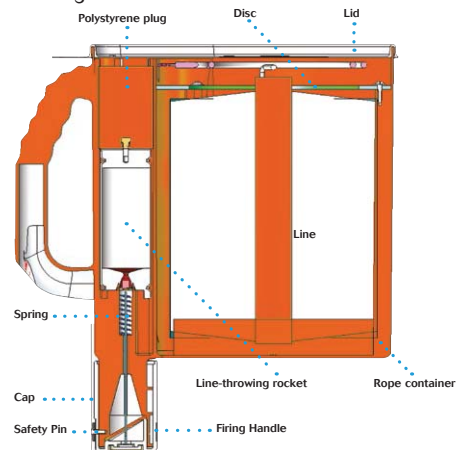

## Storage

This compact appliance is ideally stored in a water-resistant locker at ambient temperature allowing easy access in an emergency. The set of 4 appliances normally carried onboard can be dispersed in strategic positions throughout the vessel.

## Approvals

Conforms to: BAM 0589-P2-0016 (Complete Unit), 0589-P2-0094 (Rocket only), SOLAS 74 as amended, IMO resolutions MSC. 81(70) Part 1, (MED) 96/98/EC, BGV 424. 002, USCG - and other major maritime authorities worldwide.



### WARNING

- Ejects rocket projectile - do not point at people or property
- Do not fire in a confined space
- Keep out of reach of children
- For emergency use at sea
- If damaged or dented do not use
- Do not dismantle
- Keep away from source of heat
- Do not use after expiry date

### DISPOSAL

- Pyrotechnics must be treated as hazardous items and must be disposed of responsibly in accordance with local regulations.
- For help and advice, visit our website [www.comet-marine.com](http://www.comet-marine.com)

# Linethrower 250

Item Nos. Complete unit 9502000 · Body and line 9500700 · Rocket 9500800

A self-contained line-throwing appliance consisting of a weatherproof plastic casing with end cap, twist-grip trigger assembly, rocket and line. To comply with SOLAS requirements, four complete rocket and line assemblies (Item No. 9502000) should be carried on board. The device has a throwing range of between 230m and 250m. A solid propellant is used which guarantees a highly accurate flight path even in strong sidewinds.



## Application

The Pains Wessex 250 is designed for ease of operation in the most extreme weather conditions. It can be used in all situations where a line is required to be passed accurately and quickly, these include:-

- All line-throwing operations at sea between vessels, ship-to-shore, shore-to-ship and shore based rescue services.
- Rescue of swimmers in distress.
- Line carrying across obstacles and rough terrain.

## Operation



1. Remove the front cover and point in the desired flight direction.
2. Pull out safety pin.
3. Aim over the top of target. Be prepared for recoil.
4. Turn grip to left or right to fire.
5. If misfire occurs hold unit in firing position for at least 60 seconds, then dispose of overboard.

## Product Life

- Body and line kit: 9 years
- Rocket minimum 3 years
- Spare rockets are available to replace consumed or time expired rockets.

## Packing & Transport Information

**Body and Line, less rocket** in packing case,  
L 37 cm (14.57 in) x W 27 cm (10.63 in) x H 27 cm (10.63 in)

- Gross weight 4.2 kg (9.26 lb.)
- Net weight 3.6 kg (7.94 lb.)
- Other Information: Non-hazardous

**20 Spare Rockets** in metal tin in a fibreboard box,  
L 37 cm (14.57 in) x W 27 cm (10.63 in) x H 27 cm (10.63 in)

- Gross Weight Max: 13 kg (28.66 lb.)
- Net Weight Max: 10.70 kg (23.59 lb.)
- Net Explosive Content per box : 2.12 kg (4.67 lb.)
- Hazard class 1.4G
- UN 0431
- Proper shipping name: Articles, Pyrotechnic
- Other Information: Cargo Aircraft Only

## Specifications

Projects a line to a nominal range of 250m in calm conditions.

- Length: 33 cm (13.0 in)
- Height: 31.3 cm (12.3 in)
- Diameter: 20.5 cm (8.1 in)
- Gross Weight: 4.7kg (10.36 lb.)
- Net Weight: 4.4 kg (9.7 lb.)
- Rocket Weight Max: 535g (18.9 oz.)
- Explosive Content Max.: 106g (3.74 oz.)
- Line breaking strain: >2 kn

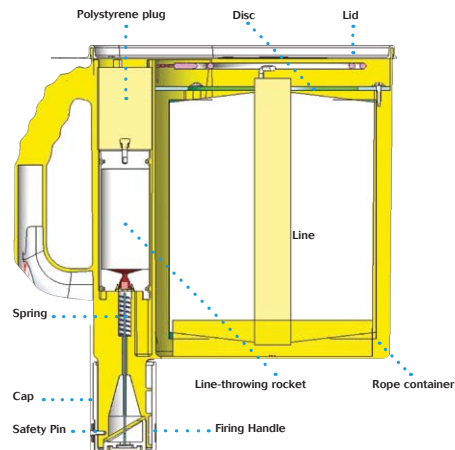

## Storage

This compact appliance is ideally stored in a water-resistant locker at ambient temperature allowing easy access in an emergency. The set of 4 appliances normally carried onboard can be dispersed in strategic positions throughout the vessel.

## Approvals

Conforms to: BAM 0589-P2-0016 (Complete Unit), 0589-P2-0094 (Rocket only), SOLAS 74 as amended, IMO resolutions MSC. 81(70) Part 1, (MED) 96/98/EC, BGV 424.003, USCG - and other major maritime authorities worldwide.



## WARNING

- Ejects rocket projectile - do not point at people or property
- Do not fire in a confined space
- Keep out of reach of children
- For emergency use at sea
- If damaged or dented do not use
- Do not dismantle
- Keep away from source of heat
- Do not use after expiry date

## DISPOSAL

- Pyrotechnics must be treated as hazardous items and must be disposed of responsibly in accordance with local regulations.
- For help and advice, visit our website [www.painswessex.com](http://www.painswessex.com)



# Line thrower

The IKAROS line thrower is used for casting a pilot line for cables and ropes in rescue operations at sea. It can be used between ships, from shore to ship or ship to shore, and for rescuing personnel.

The IKAROS line thrower is a robust device consisting of a waterproof plastic container with integral handle and trigger mechanism, a solid fuel rocket and 300 meters of line. To activate it, the user must remove a safety pin, hold the device steady and pull the trigger.

The IKAROS line thrower is approved globally and meets the latest SOLAS 74/96 regulations.

- Throws line 300 meters
- Easy to use
- Robust and waterproof
- Integral handle

## Line thrower

Performance	Throws a line in calm wind
Length of line	300 m
Line diameter	4 mm
Line strength	2 kN
Dimensions	340 x 230 mm
Weight	4 kg
Ref. no.	34 61 00 Complete line thrower
Ref. no.	34 62 00 Replacement rocket
Ref. no.	34 63 00 Buoyant head

## Line thrower replacement rocket

Each rocket has an integral igniter and includes instructions for easy installation.

Weight	650 g
Ref. no.	34 62 00

## Line buoyant head

The IKAROS line buoyant head is screwed onto the front of the rocket within the IKAROS line thrower. When released, the buoyant head floats to ensure that the line can be easily located in the water.

Weight	170 g
Ref. no.	34 63 00



# IKAROS

Swedish safety at sea since 1888



**Rescue Solutions International Inc.**  
 708 SW Umatilla Ave.  
 Redmond, OR 97756, USA  
 Phone: 541-504-9300 • Fax: 541-504-9301  
 info@resqmax.com / www.resqmax.com



## Kit 420 - RASing / UNREPS Kit



### Description

The ResQmax Kit 420 is a Replenishment At Sea (RASing)/ Underway Replenishment (UNREPS) Kit supplied with two payloads and all the accessories required to operate the ResQmax.

The Dacron Line is a messenger line which allows for long range horizontal deployment distances. This line can be used to tow larger, stronger ropes from ship-to-ship or ship-to-shore.

The Streamline Training / RASing Projectile has a high density urethane cover which absorbs the shock of impact with a hard surface and reduces the projectile 'bounce'.

The ResQmax Streamline Filler Hose facilitates charging the Projectiles with compressed air from an Air Compressor, an SCBA Tank, or a SCUBA Tank. The service pressure of these RASing Projectiles is 3,000 psi / 207 bar.

This kit comes complete with spares and a Kit Carry Bag. Optional accessories include the ResQmax Tool Kit and a Rigid Transport/Storage Case. Additional projectiles and lines are available with all of the ResQmax Kits.

**Shipping Dimensions: 25 x 21 x 14" - 26 lbs**

### Filler Hose Adapter Options

Below are the adapters available with the Filler Hose Assembly. Please select from the following choices:



SCBA Adapter  
(American Standard)  
Part #: 9111-S



SCUBA Adapter  
Part #: 9121-S



SCBA-DIN Adapter  
(European Standard)  
Part #: 9131-S



SCBA Compressor Adapter  
Part #: 9151-S



SCUBA Compressor Adapter  
Part #: 9171-S



SCBA-DIN Compressor Adapter  
Part #: 9161-S

### KIT CONTENTS:

- |                   |   |
|-------------------|---|
| 1 - Part #500     | ResQmax Launcher - Red  |
| 2 - Part #305-S   | Streamline Training Projectile (Red Cover)                          |
| 2 - Part #805     | 500lb Test 3mm Dacron Line (500ft / 152m) in Compact Line Container |
| 1 - Part #60402-S | Streamline Nozzle Protector - 5-pack                                |
| 1 - Part #714     | O-ring Kit - 10-pack (various)                                      |
| 1 - Part #715     | Corrosion Block   |
| 1 - Part #720     | ResQmax Operations Manual   |
| 1 - Part #725     | ResQmax Training CD   |
| 1 - Select        | Streamline Filler Hose (see options above)                          |
| 1 - Part #907     | Cordura Kit Carry Bag - Red   |

# line launcher

The Kiwi Rescue Line Launcher is designed for ease of operation in the most extreme weather conditions and environments. It utilises safe, widely available 16g CO2 cylinders to propel a pod connected to an 80m line accurately, safely, reliably and repeatedly.

**Uses are extensive where making a line connection between two parties is required.**

- Ship to Ship tow/transfer • Ship to Shore • Shore to Ship • Person in Distress (MOB) • Surf Lifesaving • Construction Line Transfer • Mountain/Alpine Rescue •

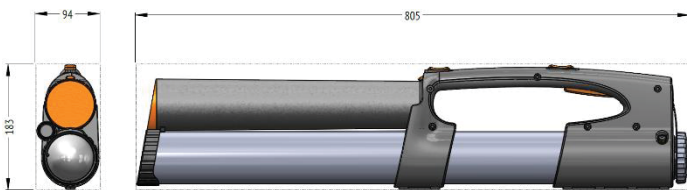

## TECHNICAL SPECIFICATION

Length:	805mm
Width:	94mm
Height:	183mm
Weight (total):	3.5kg
Materials:	2014-T6 aluminium alloy 316 stainless steel Plastic moulded parts
Pod weight:	0.43kg (floating)
Line length:	80m x 2.5mm hi-vis floating polypropylene
Propellant:	1 x 16g CO2 cylinder per launch
Range:	80m average
Reload/relaunch:	Sub 1 minute
Number of relaunches:	Unlimited
Manufactured to ISO9001 QA standards	



Sea Rescue



Military



Police



Fire Rescue



Mountain Rescue



Lake & River

For more information please contact [sales@LineLauncher.co.uk](mailto:sales@LineLauncher.co.uk) or call +44 7884 442 657



PATENT APPLICATION PENDING - RESTECH NORWAY AS

- SOLAS APPROVED
- NO EXPIRY DATE
- COMPLIES TO US/CANADA REGULATIONS
- LIFETIME EXPECTANCY AS VESSEL

<b>Article 2406</b>	<b>PLT<sup>®</sup> SOLAS Launching Unit</b>	<b>1</b>
	1 Air Cylinder, 200 bars/2900psi 1 Launching Unit 1 Cover for air cylinder	
<b>Article 2403</b>	<b>PLT<sup>®</sup> Launching Tube SOLAS Projectile</b>	<b>1</b>
<b>Article 2601</b>	<b>PLT<sup>®</sup> SOLAS Projectile</b>	<b>4</b>
	Launching range with a dry and clean line of 3,2mm (Art No 2103): 230m. Breaking strength: 2000N	
	User Manual and USB stick included	
When ordering a set please use the Article Number 2801.		

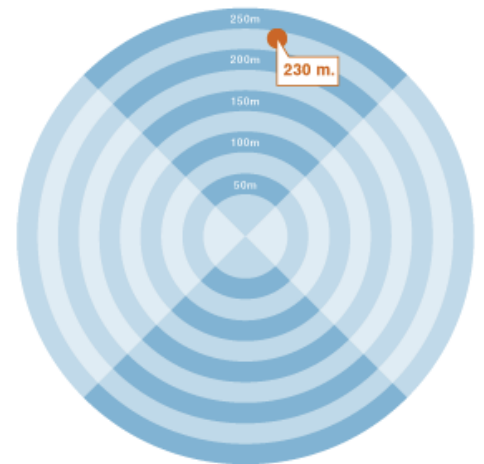

PATENT APPLICATION PENDING - RESTECH NORWAY AS

## Facts

The PLT<sup>®</sup> SOLAS US meets the IMO SOLAS regulation 74/96. You can launch up to 4 times without refilling the air cylinder. The minimum launching distance is 230 meters.

Required maintenance is 5-year hydrostatic test of the PLT<sup>®</sup> Air Cylinder. The test can be done by any certified test facility. The Air Cylinder holds the air for up to five years.

PATENT APPLICATION PENDING





# T-ISS BUMERANG BTL250

## Pneumatic Line Thrower

The BL T 250 Line Thrower is a pneumatic system which is throws projectiles by power of compressed air. BLT 250 has interchangeable launchers and easy refilling projectiles. Meets the demands of Solas/IMO regulation 74/83.

- Projectiles reaches approximately 250 meters.
- Projectiles only effected from crosswind.
- Projectiles reaches the maximum speed at end of the launcher.
- Due to aerodynamic structure, wind has the minimum effect on the projectiles.



All items are reusable. Shelf life is unlimited, if regular maintenance is done by Authorized Service's personnel. Only cost for 4 throws is refilling the cylinder with dry air.



Standard set is delivered in sturdy orange bag, wooden storage box is optional.

Complete set consists of:

- 1 BLT 250 Throwing Unit
- 4 Projectiles for BL T 250
- 1 Launcher
- 1 Training CD
- 1 User Manual

### Technical details:

Weight/Length :

Throwing Unit:	8,3kg /165cm
Projectile:	2,1kg /100cm
Total Unit:	10,4kg /175cm

Shooting Chamber Pressure:

65 bar

Average Nozzle Velocity :

50,6m/s

Maximum Recoil :

5400N

Minimum Shots :

4 projectiles

Air Cylinder Pressure :

200 bar

Volume :

2 Liters

Bag Size :

105 x 22 x 20

Total Bag Weight:

21 Kg



Cylinder can be re-filled with most common breathing air compressors

This product has been tested and proved to be qualified for delivery in conformity with the applicable standards by







# BRIDGER™ MODEL 85 LINE THROWING GUN

U.S.C.G. Approved

**USGS Approval No: 160.031/6/ - 33" X 11.5" X 8" - Weight 36 lbs.**

- 1 Bridger™ Model 85 Line Gun with line canister
- 1 Well-constructed wood box, painted red with brass hardware.
- 10 Solid brass line projectiles
- 4 600'-140 lb test nylon shot lines (2 tan & 2 orange)
- 3 Rewinding spindles
- 25 Blank cartridges – heavy load
- 1 Gun oil, cleaning solvent, cleaning rod, brush & patches
- 1 Plastic instructions and gun lock

UPGRADE to a Pelican Case! Item#CG85PEL

Optional: Add 2 Spectra 450 lb test shot lines

Note: Regulated as a firearm

Price upon request.



## PROVEN & RELIABLE

### TESTIMONIAL

*"We have the line throwing gun onboard several of our OSRVs. This is a wonderful piece of emergency gear to have onboard. This line gun for the money is the best deal in town, hands down."*

Lou Celmer - Master

OSRV New Jersey Responder

## NAVAL COMPANY, INC.

Doylestown, Pennsylvania USA

Tel: 215-348-8982 / Fax: 215-348-5637

[www.navalcompany.com](http://www.navalcompany.com)

# BIG LAUNCHER

## WATER RESCUE KIT

AMERICAN MADE AND BACKED BY A 3-YEAR WARRANTY



## THE BEST LINE DEPLOYMENT DEVICE AVAILABLE

- Easiest way to deploy a line over water or land
- Ideal for water and technical rescue operations
- Fast, accurate, and effective deployment using blank .22 caliber cartridges
- Horizontal and vertical deployment options
- Effortless in deployment of throw lines over 100 feet
- Pistol grip handle, full length shoulder length stock construction
- Reduced physical requirement for deployment
- 2 projectile models - Long distance coated rigid aluminum and Buoyant light dense foam
- Compact storage and transportation
- Used by Fire & Rescue agencies



For more information contact Lt T.C. Ryan  
TC@RescueGear.com | 512-818-4503



# BIG LAUNCHER

## WATER RESCUE KIT

AMERICAN MADE AND BACKED BY A 3-YEAR WARRANTY



For more information contact Lt T.C. Ryan

TC@RescueGear.com | 512-818-4503

BIG LAUNCHER

BIG LAUNCHER

# Emergency Vessel Attachment & Towing System



# EVATS™



ALASKA MARITIME  
PREVENTION & RESPONSE  
**NETWORK**



**Glosten**



**samson**  
THE STRONGEST NAME IN ROPE



# EVATS™ Emergency Vessel Attachment & Towing System

## A safer, more efficient method of connection for towing disabled ships

An oceangoing ship disabled at sea poses immediate problems for the crew, cargo, and rescue vessels involved. Near-shore events also bring increased risk of grounding and environmental impact. Attaching towlines in such circumstances is an exercise in seamanship and safety, often performed in conditions that put vessels and crews at extreme risk.

Existing emergency tow systems rely on a single attachment point, which can put deck hardware under unusual stress, particularly in foul weather. This can cause failures that further endanger crews and vessels.

In response to a request from the Alaska Maritime Prevention & Response Network (Network), Glasten, with support from Samson Rope Technologies, developed a unique solution called the Emergency Vessel Attachment & Towing System (EVATS™). EVATS™ is designed to overcome some of the most dangerous aspects of rescue towing, allowing faster deployment, safer operations for vessel crews, and a more secure connection.

### UNIQUE ATTACHMENT FOR SAFER EMERGENCY TOWING OPERATIONS:

- Multiple attachment points on the disabled ship
- Near-universal compatibility with ships' mooring gear arrangements
- Deployable from either ship's deck, by helicopter, or rescue vessel
- **The towing end is recovered from the water, away from the bow, unless deployed by rescue vessel**
- Rapid deployment/recovery in heavy weather and/or low-visibility
- Deployable/recoverable even when ship's deck machinery is non-functional
- Safer distances between the disabled ship and the rescue vessel

### KEY FEATURES:

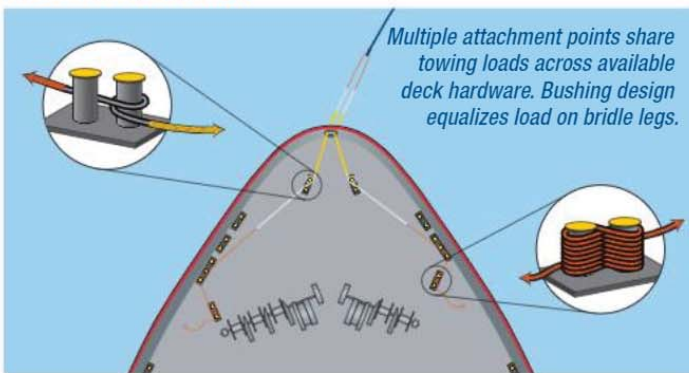

- > Ultra high-strength high-modulus polyethylene (HMPE) buoyant line with proprietary design
- > Components sized to pass through standard ships' chocks
- > Chafe protection
- > Hawser bushing for distribution of line loads
- > Additional flotation on towing end of hawser
- > Bridle legs can be rigged asymmetrically
- > Retrieving system with drag device and strobing buoy
- > Compatible with large sea anchors and other drag devices

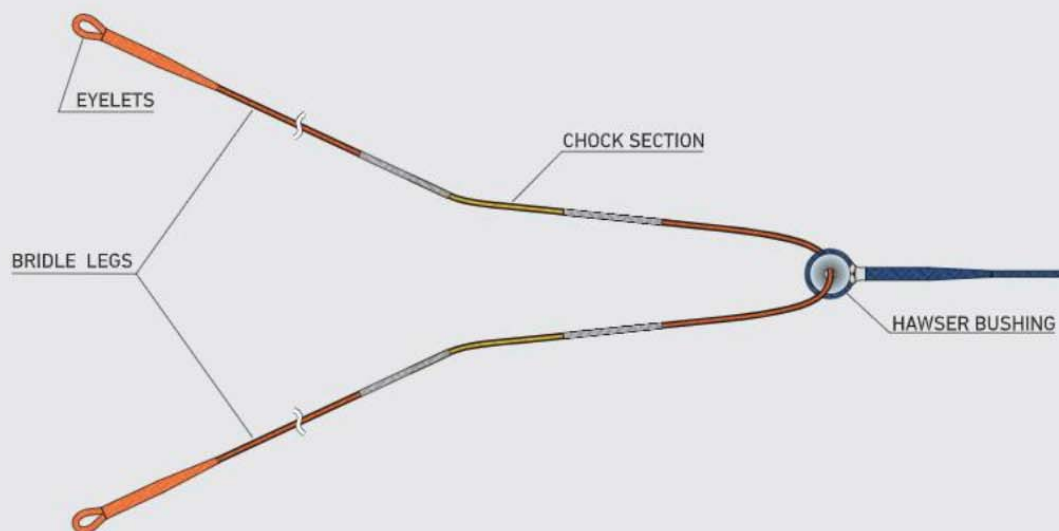

PATENTED DESIGN



## EVATS™: Not just a tow line, but an emergency towing system

### THE EVATS SYSTEM CONSISTS OF:

THE TOWING BRIDLE, constructed of Samson *Quantum-X*™, leads through the centerline chock on the disabled ship and attaches to multiple deck fittings. Engineered for improved snag resistance and a higher coefficient of friction, *Quantum-X* offers enhanced grip on bits and chocks relative to conventional HMPE ropes. Chafe protection provides increased security where contact is made with the ship's structure.

THE HAWSER BUSHING is sized to fit through most chocks and provides a secure, non-abrasive connection between the bridle to the towing hawser. Made of marine-grade aluminum, it is easy to handle and incorporates optimized line bend ratios to retain the full strength of the rope. The bushing allows the bridle legs to share towing loads equally, even when rigged asymmetrically.

THE TOWING HAWSER constructed of Samson *AmSteel®Blue*, combines extreme strength with ease of handling and positive buoyancy. Tubular line floats are added to ensure the Orkot® thimble remains readily recoverable at the water's surface.

THE RETRIEVING LINE incorporates a pilot anchor to stream the hawser to windward when deployed from a disabled and drifting ship. This allows the rescue vessel to stand off while retrieving the tow system rather than attempting close maneuvers. Additional floats and a strobing beacon make it visible in darkness or periods of reduced visibility.

### A flexible system for emergency tows

EVATS is stored in its own container for convenient handling; it is easily added to the safety gear on board most vessels. At under 2,000 pounds, it is light enough to be carried by most emergency helicopters stationed in remote areas. If necessary, EVATS can be delivered to a disabled ship from the deck of the rescue vessel.



### 300MT EVATS COMPONENTS\* Ultra-high strength (HMPE) buoyant lines

Towing Bridle	<b>Quantum-X®</b>	
	MINIMUM BREAK STRENGTH	354** mt
	BRIDLE LEG LENGTH	75 m
	DIAMETER	68 mm

\*\*Bridle configuration

Towing Hawser	<b>AmSteel®Blue</b>	
	MINIMUM BREAK STRENGTH	300 mt
	LENGTH	146 m
	DIAMETER	68 mm

<b>Hawser Bushing</b>	
MINIMUM BREAK STRENGTH	300 mt
DIAMETER	31 cm

*Packaged in a cargo net inside the crate for quick deployment via helicopter.*

### PACKAGED SYSTEM

<b>Crate</b>		
WIDTH	230 cm	HEIGHT 120 cm
LENGTH	150 cm	WEIGHT < 2,000 lb



\*400MT EVATS in development



*Messenger line included for deployment from responding vessel.*



# EVATS™

## Emergency Vessel Attachment & Towing System

### Flexible emergency towing system can be deployed from disabled ship or responding vessel

Emergency situations at sea seldom follow accepted safety best practices. The conventional method of attaching an emergency towing hawser to a disabled ship requires responding vessels to maneuver in close proximity to the ship's bow in extreme conditions. EVATS has been designed to avoid this dangerous operation, allowing faster deployments and safer retrieval of the towing hawser. Deployment and attachment can be carried out even when the disabled ship is in a blackout condition (no power to deck machinery).

EVATS can be deployed by the disabled ship, the responding vessel, or delivered via rescue helicopters commonly used for marine casualty response.

The EVATS system was developed in response to a request from the Alaska Maritime Prevention & Response Network (Network) by Glosten with assistance from Samson.



*Bringing a disabled ship under tow during inclement weather is perhaps the most dangerous, demanding operation responding vessels and their crews face.*

### THE NETWORK [AlaskaSeas.org](http://AlaskaSeas.org)

The Alaska Maritime Prevention & Response Network is a non-profit organization governed by industry representatives that provides vessels operating in Western Alaska and Prince William Sound best management practices and response capabilities to comply with Federal tank and non-tank oil pollution prevention and response regulations.

### GLOSTEN [Glosten.com](http://Glosten.com)

Glosten is a full-service naval architecture and marine engineering consultancy with specialized expertise in marine operations, vessel motion and loads analysis. Glosten serves vessel operators and contractors performing challenging in-water projects.

### SAMSON [SamsonRope.com](http://SamsonRope.com)

Samson is the worldwide leader in the development and manufacture of high-performance ropes, with a focus on research and development, and solving specific customer applications.

The EVATS™ system is the subject of the following pending patent applications: U.S. Patent Application Nos. 15/611,384 and 15/611,195 and International Patent Application Nos. PCT/US2017/037732 and PCT/US2017/037673.

EVATS™ is a trademark of The Alaska Maritime Prevention & Response Network  
© 2018/2019 Samson Rope Technologies, Inc. ALL RIGHTS RESERVED. 1/2019



[SamsonRope.com](http://SamsonRope.com)





# Emergency Tow Packages

## Easy, light, ready-to-go tow lines in one simple container

Cortland offers a full range of high performance synthetic rope solutions which are stronger, safer, lighter and easier to handle than wire rope.

One standard solution is Cortland's Emergency Tow Package system, containing all elements needed for quick response to tow and recovery needs. The ETS-450 and ETS-900 Emergency Tow Packages are complete rope assemblies consisting of a Plasma® Tow Line with thimble eyes, Spectra® floating pickup line and lighted buoy all stored inside a weather proof plastic container.

### Tow Line

Cortland's floating tow lines are made with a soft, torque-free braided construction and high visibility urethane coating. Unlike Kevlar® lines, they do not require special large radius chocks or fairleads and can be handled in the same manner as regular towing hawsers.

**ETS-450** – 56mm dia (7" circ) x 76 meter (250-ft) of Plasma® 12 Strand

**ETS-900** – 80mm dia (10" circ) x 91 meter (300-ft) of Plasma® 12 Strand

The ETS-450 has a minimum break strength of 2,000 kN (450,000 lbs), meeting the requirements for tankers under 50,000 dwt. The ETS-900 has a minimum break strength of 4,000 kN (900,000 lbs) meeting the requirements for tankers over 50,000 dwt.

### Pickup Line

The pick-up line is a high visibility Spectra® 12 Strand floating rope with a minimum break strength of 200 kN (45,000 lbs): 22mm (7/8 inch) diameter x 122 meters (400-ft).

### Lighted Buoy

An automatically activated lighted buoy, small enough to fit through any chock and that will accept the tow line thimbles, is also included.

### Storage Box

All items arrive inside a heavy duty polypropylene storage container, which is ready to attach to the deck. The line is flaked into the container for easy attachment and deployment.

### Features

- Complete assemblies, including a Plasma® tow line, Spectra® floating pick up line, and lighted buoy
- Weights:
  - 550 lbs ETS-450
  - 1,100 lbs ETS-900
- All components in compliance with 1994 SOLAS Convention requirements
- All contained in a weatherproof polypropylene container

### Innovative solutions. Custom built.

Call us for your next project or email us at [cortland@cortlandcompany.com](mailto:cortland@cortlandcompany.com).

